

May 2022

DS100 Series Thermostatic Steam Traps



WARNING

Failure to follow these instructions or to properly install and maintain this equipment could result in an explosion, fire and/or chemical contamination causing property damage and personal injury or death.

The DS100 Series steam trap must be installed, operated and maintained in accordance with federal, state and local codes, rules and regulations and Emerson Process Management Regulator Technologies, Inc. (Emerson) instructions. If leak develops in the system, service to the unit may be required. Failure to correct trouble could result in a hazardous condition.

Installation, operation and maintenance procedures performed by unqualified personnel may result in improper adjustment and unsafe operation. Either condition may result in equipment damage or personal injury. Only a qualified person shall install or service the DS100 Series steam trap.



Figure 1. DS100 Series Thermostatic Steam Trap

Introduction

Scope of the Manual

This manual provides instructions for operation, installation and parts ordering for the DS100 Series

Product Description

A steam trap is an automatic valve which discharges condensate, undesirable air and non-condensibles from a system while trapping, or holding in, steam.

Thermostatic steam traps operate in direct response to the temperature within the trap.

The DS100 Series are thermostatically actuated and maintenance free. Actuator is single piece, fail open design consisting of 1.2 in. / 12.7 mm diameter, welded 316L stainless steel plates. Trap is constructed entirely of 316L stainless steel components with wetted body surfaces finished to 20 μ in. Ra or better. Trap is self draining when installed vertically in piping systems. It has a tube or universal ferruled connections. Ferruled connections is Tri-clamps compatible and designed to fit both 1/2 and 3/4 in. / 12.7 and 19.1 mm service.

DS100 Series

Specifications

The Specifications section gives some general specifications for the DS100 Series thermostatic steam traps. The nameplates give detailed information for a specific steam trap as built in the factory.

Available Configurations

Type DS100: Ferrule clamp end 1 7/8 in. /
47.6 mm OAL

Type DS100TE: Tube end

Type DS110: Ferrule clamp end 2 5/8 in. /
66.7 mm OAL

Body Sizes

NPS 1/2, 3/4, 1 and 1-1/2/ DN 15, 20, 25 and 40

End Connection Styles

Tube

Ferrule

Maximum Operating Temperature⁽¹⁾

366°F / 186°C

Maximum Operating Pressure⁽¹⁾

150 psig / 10.3 bar

Maximum Allowable Temperature⁽¹⁾

500°F / 260°C

Maximum Allowable Pressure⁽¹⁾

300 psig / 20.7 bar

Construction Materials

316L Stainless steel

Body Surface Finish

<20 µ in. RA internal

Machine Polished external

Option

Check valve for Type DS110

Applications

CIP/SIP System Condensate Drainage

Sterilization of Process Vessels

Culinary Steam

Humidifiers

WFI System Sterilization

Main Drips

Approximate Weights

1.1 to 1.6 lbs / 0.5 to 0.73 kg

1. The pressure/temperature limits in this Instruction Manual and any applicable standard or code limitation should not be exceeded.

Principle of Operation

Thermal actuator is filled at its free length with a liquid having a lower boiling point than water. On start-up, valve is normally open to discharge air, non-condensibles and condensate. When steam enters trap, thermal actuator fill vaporizes to a pressure higher than line pressure. This forces valve into seat orifice to prevent any further flow. As condensate collects, it takes heat from thermal actuator, lowering internal pressure. Line pressure will then compress thermal actuator to open valve and discharge condensate. Valve opening automatically adjusts to load conditions from minimum on very light loads to full lift at maximum load.

Installation



WARNING

Personal injury or system damage may result if this steam trap is installed, without appropriate overpressure protection, where service conditions could exceed the limits given in the Specifications section and/or steam trap nameplate.

Additionally, physical damage to the steam trap may result in personal injury or property damage due to escaping of accumulated gas. To avoid such injury and damage, install the steam trap in a safe location.

All pressure equipment should be installed in a non-seismic area; should not be exposed to fire; and should be protected from thunderbolt (lightning) strikes.

1. Before installing trap, blow all dirt and scale from apparatus and piping.
2. Install trap with arrow on body in flow line as close as possible to apparatus with strainer and valve upstream of trap.
3. Pitch all drain lines toward trap.

Note

Approved practice is to install separate traps on each piece of apparatus to be drained. Steam supplied to inlets of several units may be of uniform pressure, but invariably there is a differential at the outlets. Although this differential may be small, unit discharging highest pressure will control the action of trap, while other units become air-bound and water logged. Piping upstream and downstream of trap should be at least equal to or one size larger than trap connection.

4. Record the location of the trap for maintenance accessibility.

Maintenance

The DS100 Series thermostatic steam traps are sealed units making it maintenance free. It is composed of corrosion resistant stainless steel components with welded construction to prevent damage to actuator. No bolts, gaskets or adjustments are necessary.

Parts Ordering

When corresponding with your local Sales Office about the DS100 Series, always reference the assembly number.

Parts List

Key	Description	Part Number	
1	Inlet connection		
	Tube		
	NPS 1/2 / DN 15	WAL423212	
	NPS 3/4 / DN 20	WAL423214	
	NPS 1 / DN 25	WAL423216	
	Ferrule		
	NPS 1/2 and 3/4 / DN 15 and 20 (For Types DS100 and DS110)	WAL423191	
	NPS 1 and 1-1/2 / DN 25 and 40	WAL423319	
	2	Outlet connection	
		Type DS100	
Tube			
NPS 1/2 / DN 15		WAL423213	
NPS 3/4 / DN 20		WAL423215	
NPS 1 / DN 25		WAL423217	
Ferrule			
NPS 1/2 and 3/4 / DN 15 and 20		WAL423192	
NPS 1/2 and 3/4 / DN 15 and 20 SLR		WAL423393	
NPS 1 and 1-1/2 / DN 25 and 40		WAL423320	
3	Types DS110		
	Ferrule		
	NPS 1/2 and 3/4 / DN 15 and 20	WAL423542	
4	NPS 1/2 and 3/4 / DN 15 and 20 SLR	WAL423545	
	NPS 1 and 1-1/2 / DN 25 and 40	WAL423772	
	Bellows Assembly	WAL0015507	
	Check Valve (not shown)		
4	NPS 1/2 and 3/4 / DN 15 and 20	WAL0016351	
	NPS 1 and 1-1/2 / DN 25 and 40	WAL0016355	

DS100 Series

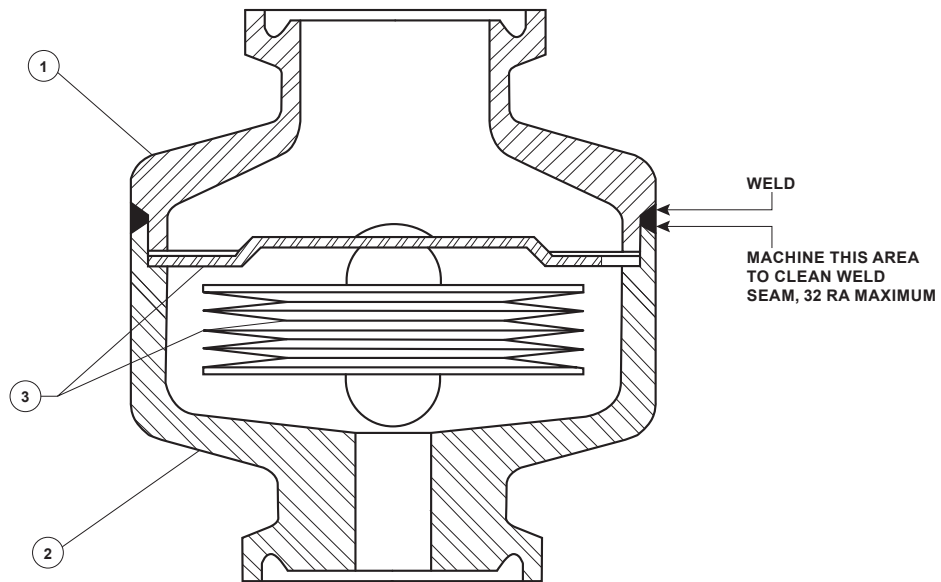

Figure 2. DS100 Series Assembly Drawing

 SpenceValve.com

Emerson Automation Solutions

Americas

McKinney, Texas 75070 USA
T +1 800 558 5853
+1 972 548 3574

Europe

Bologna 40013, Italy
T +39 051 419 0611

Asia Pacific

Singapore 128461, Singapore
T +65 6777 8211

Middle East and Africa

Dubai, United Arab Emirates
T +971 4 811 8100

VCIMD-17103 © 2022 Emerson Electric Co. All rights reserved. 05/22
Spence is a mark owned by one of the companies in the Emerson Automation Solutions business unit of Emerson Electric Co. The Emerson logo is a trademark and service mark of Emerson Electric Co. All other marks are property of their prospective owners.

The contents of this publication are presented for informational purposes only, and while every effort has been made to ensure their accuracy, they are not to be construed as warranties or guarantees, express or implied, regarding the products or services described herein or their use or applicability. All sales are governed by our terms and conditions, which are available upon request. We reserve the right to modify or improve the designs or specifications of such products at any time without notice.

Emerson Electric Co. does not assume responsibility for the selection, use or maintenance of any product. Responsibility for proper selection, use and maintenance of any Emerson Electric Co. product remains solely with the purchaser.

