

pH Theory Guide

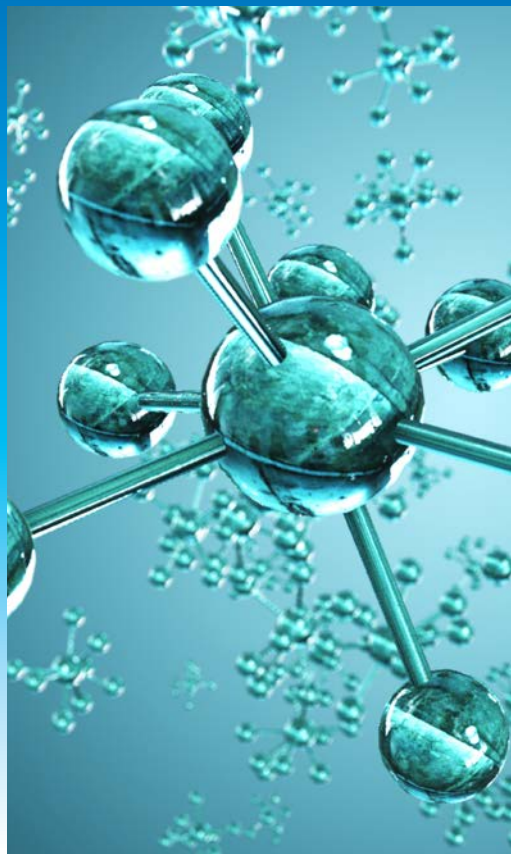

Mettler-Toledo GmbH
Process Analytics

Industry
Environment

A Guide to pH Measurement

Theory and Practice of pH Applications

METTLER **TOLEDO**

A Guide to pH Measurement

Theory and Practice of pH Applications

Content

Preface	8
1 Introduction to pH	9
1.1 Acidic or alkaline?	9
1.2 Why are pH values measured?	11
1.3 The tools for pH measurements	12
1.3.1 The pH electrode	13
1.3.2 Reference electrodes	15
1.3.3 Combination electrodes	16
1.4 What is a pH measuring system?	17
2 Practical considerations	18
2.1 The pH measuring system	18
2.2 Obtaining an accurate pH measurement	19
2.2.1 General principles of pH measurement	19
2.2.2 Industrial pH measurement	21
2.2.3 Signal processing and environmental influences	24
2.2.4 Calibration	28
2.2.5 Buffer solutions	29
2.3 How to maintain a reliable signal	30
2.3.1 Maintenance of the electrode function	30
2.3.2 Storage	33
2.3.3 Temperature compensation	33
2.4 Troubleshooting	37
2.4.1 Instructions and comments for the troubleshooting diagram	37
3 Intelligent Sensor Management	42
3.1 Signal integrity	42
3.2 Pre-calibration	43
3.3 Predictive diagnostics	43
3.4 Asset management software	45
3.4.1 Electronic documentation	45
3.4.2 Sensor management	46

4	Electrode selection and handling	48
4.1	Different kinds of junction	48
4.1.1	Ceramic junctions	48
4.1.2	PTFE annular diaphragm	50
4.1.3	Open junctions	51
4.1.4	Dual-membrane without junction	51
4.2	Reference systems and electrolytes	52
4.3	Types of membrane glass and membrane shape	56
4.4	pH electrodes for specific applications	58
4.4.1	Highly accurate problem solver	58
4.4.2	Complex samples or such of unknown composition	59
4.4.3	Semi-solid or solid samples	60
4.4.4	At the toughest applications in chemical process industries	61
4.4.5	Prepressurized electrolyte pH electrodes	62
4.4.6	Dual-membrane pH electrodes	63
4.4.7	pH measurements in high purity water samples	64
4.4.8	Installation in an upside-down position	65
4.4.9	For food and beverage applications	66
4.4.10	For low maintenance and simple installation	67
4.5	Electrode maintenance	68
4.6	Electrode storage	68
4.6.1	Short term storage	68
4.6.2	Long term storage	69
4.7	Electrode cleaning	69
4.7.1	Blockage with silver sulfide (Ag_2S)	69
4.7.2	Blockage with silver chloride (AgCl)	70
4.7.3	Blockage with proteins	70
4.7.4	Other junction blockages	70
4.8	Electrode regeneration and lifetime	70

5	Comprehensive pH theory	71
5.1	Definition of the pH value	71
5.2	Correlation of concentration and activity	72
5.3	Buffer solutions	75
5.3.1	Buffer capacity (β)	77
5.3.2	Dilution value (ΔpH)	78
5.3.3	Temperature effect ($\Delta\text{pH}/\Delta T$)	78
5.4	The measurement chain in the pH measurement setup	78
5.4.1	pH electrode	80
5.4.2	Reference electrode	81
5.5	Calibration / adjustment of the pH measurement setup	84
5.6	The influence of temperature on pH measurements	85
5.6.1	Temperature dependence of the electrode	85
5.6.2	Isothermal intersection	86
5.6.3	Further temperature phenomena	87
5.6.4	Temperature dependence of the measured sample	88
5.7	Phenomena in the case of special measuring solutions	89
5.7.1	Alkaline error	89
5.7.2	Acid error	90
5.7.3	Reactions with the reference electrolyte	90
5.7.4	Organic media	91
5.8	Signal processing	93
6	Mathematical parameters	99

Figures

Figure 1	The reaction of an acid and a base forms water	9
Figure 2	Dissociation of acetic acid	9
Figure 3	The formula for calculating the pH value from the concentration of hydronium ions	9
Figure 4	pH values for some chemicals and everyday products	10
Figure 5	The reaction of ammonia with water	10
Figure 6	The relationship between the amount of acid in solution and the output potential of a pH electrode	12
Figure 7	The measurement assembly of pH and reference electrode	13
Figure 8	Cross sections through the glass membrane	14
Figure 9	pH electrode with pH-sensitive membrane	14
Figure 10	Reference electrode with reference electrolyte, reference element and junction	15
Figure 11	Typical combination pH electrode with inner pH sensor and outer reference element	16
Figure 12	pH measurement system	17
Figure 13	InTrac 776 e	22
Figure 14	Industrial measuring sites	23
Figure 15	Signal transformation	24
Figure 16	Complete measurement system	27
Figure 17	Electrode with built-in electrolyte bridge	32
Figure 18	Calibration line and isothermal intersection points	35
Figure 19	Symmetrical structure of an Equithal®-system in comparison with a conventional electrode	36
Figure 20	Troubleshooting diagram	38
Figure 21	Electrode with ceramic junction	49
Figure 22	Example of electrode with PTFE diaphragm	50
Figure 23	Example of electrode with open junction	51
Figure 24	Dual-membrane pH electrode	52
Figure 25	Schematic drawing of the ARGENTHAL™ reference system	53
Figure 26	Differently shaped pH membranes	56
Figure 27	InPro 200x (i)	58
Figure 28	InPro 426x (i)	59

Figure 29	Puncture pH electrode	60
Figure 30	InPro 480x (i)	61
Figure 31	InPro 325x (i)	62
Figure 32	InPro 4850 i	63
Figure 33	pHure Sensor™	64
Figure 34	InPro 3100 (i)	65
Figure 35	InPro 3300 (ISFET pH sensor)	66
Figure 36	InPro 4501	67
Figure 37	InPro 4550	67
Figure 38	Buffering capacity of acetic acid	77
Figure 39	Temperature dependence for the pH electrode slope factor	79
Figure 40	Different sources of potential in a combination electrode	79
Figure 41	Ion mobility and diffusion of ions through a junction	82
Figure 42	Left: offset adjustment of a pH electrode in the pH meter, right: slope adjustment of a pH electrode. Solid lines show ideal behavior, dashed lines show real behavior	85
Figure 43	Isothermal intersection, theory and practice	87
Figure 44	Illustration of alkaline and acid error electrode behavior	90
Figure 45	pH scale for different solvents	92
Figure 46	Typical process control loop	93
Figure 47	Intersection of the process control system and sensor/activator system	94

Preface

The aim of this book is to give a representative description of pH measurement in the process industries. The actual sensor, the pH electrode, is therefore the main focus of the text. Correct sensor use is fundamental for a meaningful pH measurement. Accordingly, both practical and theoretical requirements are discussed in depth so that the measuring principle is understood and an accurate measurement made possible.

The first section (practical considerations) of the book describes the sensor, and the other elements that constitute a pH measurement system. Together with a troubleshooting diagram, this section gives the information needed in order to ensure the correct working of the pH electrodes for long periods of time. The second, application orientated section gives solutions to different measuring tasks, giving examples from the lab and from industry. The last, theoretical part explains the basis of the pH measurement and completes, by further explanation, the information given in the first section.

In addition, this book is outlined to be a useful tool in solving different measuring tasks. Thereby it can be read either in its totality or in parts.

1 Introduction to pH

1.1 Acidic or alkaline?

Why do we classify an everyday liquid like vinegar as being acidic? The reason is that vinegar contains an excess of hydronium ions (H_3O^+) and this excess of hydronium ions in a solution makes it acidic. An excess of hydroxyl ions (OH^-) on the other hand makes something basic or alkaline. In pure water the hydronium ions are neutralized by hydroxyl ions, therefore this solution has a neutral pH value.



Figure 1 The reaction of an acid and a base forms water.

If the molecules of a substance release hydrogen ions or protons through dissociation we call this substance an acid and the solution becomes acidic. Some of the most well-known acids are hydrochloric acid, sulfuric acid and acetic acid or vinegar. The dissociation of acetic acid is shown below:



Figure 2 Dissociation of acetic acid.

Not every acid is equally strong. Exactly how acidic something is, is determined by the total number of hydrogen ions in the solution. The pH value is then defined as the negative logarithm of the hydrogen ion concentration. (To be precise, it is determined by the activity of the hydrogen ions. See "5.2 Correlation of concentration and activity" on page 72 for more information on the activity of hydrogen ions).

$$\text{pH} = -\log [\text{a}_{\text{H}^+}]$$

Figure 3 The formula for calculating the pH value from the concentration of hydronium ions.

The quantitative difference between acidic and alkaline substances can be determined by performing pH value measurements. A few examples of pH values of everyday substances and chemicals are given in Figure 4 below.

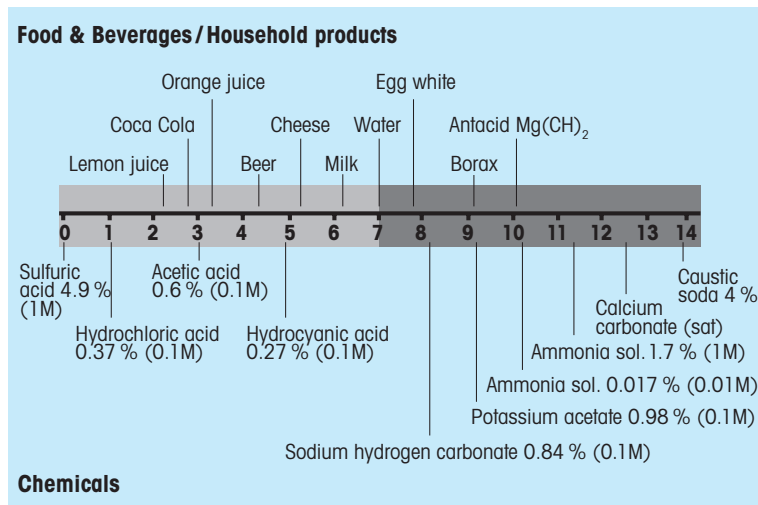

Figure 4 pH values for some chemicals and everyday products.

The alkaline end of the scale is between pH 7 and 14. At this end of the scale the hydroxyl or OH⁻ ions are present in excess. Solutions with these pH values are created by dissolving a base in an aqueous solution. The base dissociates to release hydroxyl ions and these make the solution alkaline. Among the most common bases are sodium hydroxide, ammonia, and carbonate.



Figure 5 The reaction of ammonia with water.

The whole scale of pH values in aqueous solutions includes both the acidic and alkaline ranges. The values can vary from 0 to 14, where pH values from 0 to 7 are called acidic and pH values from 7 to 14 are termed alkaline. The pH value of 7 is neutral.

1.2 Why are pH values measured?

We measure pH for a lot of different reasons, such as:

- **to produce products with defined properties** – During production it is important to control the pH to ensure that the end product conforms with the desired specifications. The pH can dramatically alter the properties of an end product such as appearance or taste.
- **to lower production costs** – This is related to the above mentioned reason. If the yield of a certain production process is higher at a given pH, it follows that the costs of production are lower at this pH.
- **to avoid doing harm to people, materials and the environment** – Some products can be harmful at a specific pH. We have to be careful not to release these products into the environment where they can be a danger to people or damage equipment. To be able to determine whether such a substance is dangerous we first have to measure its pH value.
- **to fulfill regulatory requirements** – As seen above, some products can be harmful. Governments therefore put regulatory requirements in place to protect the population from any damage caused by dangerous materials.
- **to protect equipment** – Production equipment that comes into contact with reactants during the production process can be corroded by the reactants if the pH value is not within certain limits. Corrosion shortens the lifetime of the production line, therefore monitoring pH values is important to protect the production line from unnecessary damage.
- **for research and development** – The pH value is also an important parameter for research purposes such as the study of biochemical processes.

These examples describe the importance of pH in a wide range of applications demonstrating why it is so often determined.

1.3 The tools for pH measurements

To be able to measure pH you need to have a measurement tool which is sensitive to the hydrogen ions that define the pH value. The principle of the measurement is that you take a sensor with a glass membrane which is sensitive to hydrogen ions and observe the reaction between it and a sample solution. However, the observed potential of the pH-sensitive electrode alone does not provide enough information and so we need a second sensor. This is the sensor that supplies the reference signal or potential for the pH sensor. It is necessary to use the difference between both these electrodes in order to determine the pH value of the measured solution.

The response of the pH-sensitive electrode is dependent on the H^+ ion concentration and therefore gives a signal that is determined by how acidic/alkaline the solution is.

The reference electrode on the other hand is not responsive to the H^+ ion concentration in the sample solution and will therefore always produce the same, constant potential against which the pH sensor potential is measured.

The potential between the two electrodes is therefore a measure of the number of hydrogen ions in the solution, which by definition gives the pH value of the solution. This potential is a linear function of the hydrogen concentration in the solution, which allows quantitative measurements to be made. The formula for this function is given in Figure 6 below:

$$E = E_0 + 2.3 \frac{RT}{nF} \times \log [a_{H^+}]$$

Figure 6 The relationship between the amount of acid in solution and the output potential of a pH electrode.

E = measured potential

E_0 = constant

R = gas constant

T = temperature in degrees Kelvin

n = ionic charge

F = Faraday constant

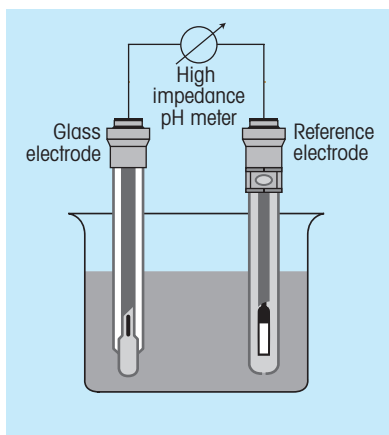

Figure 7 The measurement assembly of pH and reference electrode.

In Figure 7 a pH measurement setup with two separate electrodes, a pH electrode and a reference electrode, is shown. Nowadays, a merger of the two separate electrodes into one sensor is very common and this combination of reference and pH electrodes is called the combination pH electrode. Each of these three electrodes is different and has its own important features and properties.

1.3.1 The pH electrode

The pH electrode is the part that actually senses the pH in the solution. It consists of a glass shaft with a thin glass membrane at the end, sensitive to H^+ ions. The outside of this membrane glass forms a gel layer when the membrane comes into contact with an aqueous solution. A similar gel layer is also formed on the inside of the membrane glass, since the electrode is filled with an inner aqueous electrolyte solution. An example of this gel layer is shown in Figure 8 below:

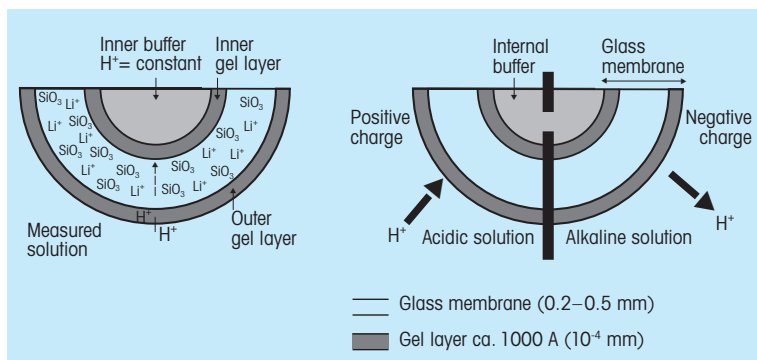

Figure 8 Cross sections through the glass membrane.

The H^+ ions in and around the gel layer can either diffuse into or out of this layer, depending on the pH value and therefore the H^+ ion concentration of the measured solution. If the solution is alkaline the H^+ ions diffuse out of the layer and a negative charge is established on the outer side of the membrane. If the solution is acidic the reverse happens, H^+ ions diffuse into the layer and a positive charge builds-up on the outer side of the membrane. Since the glass electrode has an internal buffer with a constant pH value, the potential on the inner surface of the membrane remains constant during the measurement. The pH electrode potential is therefore the difference between the inner and outer charge of the membrane. A drawing of a standard pH electrode is shown in Figure 9 below.

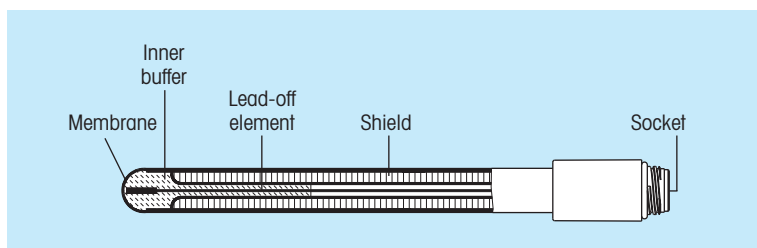

Figure 9 pH electrode with pH-sensitive membrane.

1.3.2 Reference electrodes

The purpose of the reference electrode is to provide a defined stable reference potential for the pH sensor potential to be measured against. To be able to do this the reference electrode needs to be made of a glass which is not sensitive to the H^+ ions in the solution. It must also be open to the sample environment into which it is dipped. To achieve this, an opening or junction is made in the shaft of the reference electrode through which the inner solution or reference electrolyte is in contact with the sample. The reference electrode and pH half-cell have to be in the same solution for correct measurements. A picture of a typical reference electrode is shown in Figure 10 below:

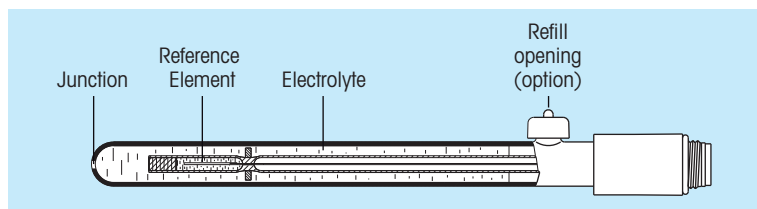

Figure 10 Reference electrode with reference electrolyte, reference element and junction.

The construction of the electrode is such that the internal reference element is immersed in a defined reference buffer and is indirectly in contact with the sample solution via the junction. This contact chain ensures a stable potential.

There are several reference systems available, but the one used almost exclusively today is the silver/silver chloride system. The potential of this reference system is defined by the reference electrolyte and the silver/silver chloride reference element. It is important that the reference electrolyte has a high ion concentration which results in a low electrical resistance (see "5.4 The measurement chain in the pH measurement setup" on page 78 for more details).

Since the reference electrolyte flows into the sample solution during measurement, you should be aware of any possible reactions between the reference electrolyte and the sample solution as this can affect the electrode and measurement.

1.3.3 Combination electrodes

Combination electrodes (see Figure 11 below) are much easier to handle than two separate electrodes and are very commonly used today. In the combination electrode the pH-sensitive glass electrode is concentrically surrounded by the reference electrode filled with reference electrolyte.

The separate pH and reference parts of the combination electrode have the same properties as the separate electrodes; the only difference is that they are combined into one electrode for ease of use. Only when the two components of the combination electrode are expected to have very different life expectancies is the use of individual pH and reference electrodes recommended rather than a single combined electrode.

To further simplify pH measurements, it is possible to house a temperature sensor in the same body as the pH and reference elements. This allows temperature compensated measurements to be made. Such electrodes are also called 3-in-1 electrodes.

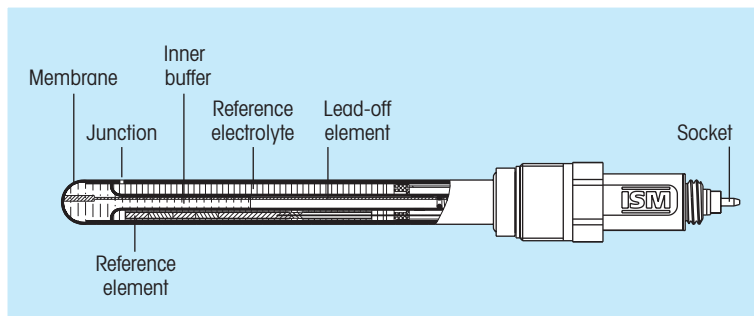

Figure 11 Typical combination pH electrode with inner pH sensor and outer reference element.

1.4 What is a pH measuring system?

An electrode housing is necessary in order to protect and securely hold the pH electrode in a continuous industrial process.

The function of a pH transmitter is to present the signals of the electrode in a suitable way; for instance with the help of a pH display or an output for a recording device. The different components of the pH measuring system can be summarized as follows:

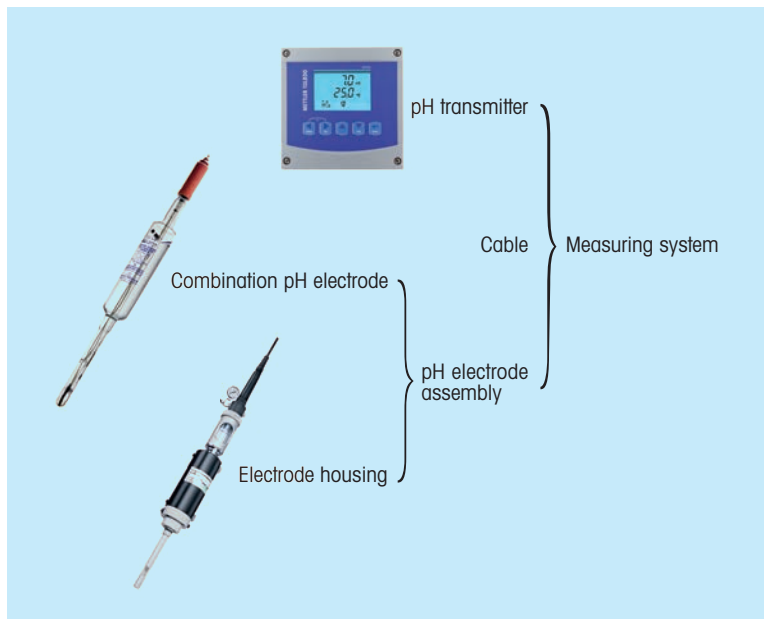

Figure 12 pH measurement system.

2 Practical considerations

2.1 The pH measuring system

Correct pH measurement can only be achieved through the proper design of the measuring system, including the measuring site.

What makes a pH measuring system?

In the lab:

Suitable electrode

Holder	Positions and protects the pH electrode against mechanical damages
Thermometer	Temperature control
Laboratory pH meter	Calibration of electrode, pH value display
Buffer solution	Calibration
Electrolyte solution	Storage and refill of electrodes
Dist. water	Cleaning of the electrode
Stirrer	Generates a homogenous measuring solution (medium)
Beaker	Measuring, calibrating and cleaning

In industry:

Suitable electrode

Electrode housing	Protection. It should be of such a design that measurement and maintenance of the electrode can be optimally done
Temp. sensor	Temperature compensation
pH transmitter	Calibration, monitoring and control of the process
Buffer solution	Calibration
Electrolyte solution	Storage and refill of electrolyte
Cleaning system	Cleaning and calibrating of the electrode

2.2 Obtaining an accurate pH measurement

2.2.1 General principles of pH measurement

For an optimal pH measurement to be possible, the correct electrode must first be selected.

This is done with respect to the following criteria:

- chemical composition
- temperature
- pH range
- pressure
- vessel size

Special solutions demand special electrolytes

Under certain circumstances, in special applications, it is necessary not only to choose the right electrode, but also to use a special electrolyte. This is, for instance, the case with very protein-rich solutions, or with non-aqueous or partly aqueous solutions.

Modern pH transmitters allow both manual and automatic temperature compensation (see “5.6 The influence of temperature on pH measurements” on page 85). If the pH measurement is, however, always taken

at the same temperature, an automatic temperature compensation is unnecessary.

To document the measured values it is advisable to use a transmitter with a recorder output.

– Defined measuring conditions

The requirements for reproducible and accurate pH measurements are to have defined measuring conditions. Two main points have to be considered:

- **Known temperature:** If pH values of different measurements are to be compared, it is important that they were made at the same temperature.

- **Homogeneity:** A solution in which sediments are present has to be stirred in order to stay physically and chemically homogeneous. Time can also play an important role, especially with samples of a low buffer capacity, in samples with a low (or no) salt content. CO_2 , (from the atmosphere), for example, dissolves in such samples, causing a change in pH value.

– Response time and accuracy of the electrode

In order to achieve accurate measuring results, calibration must be done before each measurement. A new electrode in a standard buffer (pH values 4; 7; 9.2) has a response time of less than 5 sec. to achieve a stable reading to ± 0.01 pH units.

At extreme pH values the response time of the electrode may increase. If a stable pH value is not reached over a longer period of time, the cause may be one of a variety of problems (see “2.4 Troubleshooting” on page 37).

The accuracy of the measured pH value depends on the maintenance of the electrode, the measuring solution (extreme pH values, contamination) the temperature, the pressure, the choice of the electrode and fresh buffer solution. A standard buffer solution should have an accuracy of ± 0.02 pH units.

– How to handle the electrode

The electrode is a sensitive device and should not be misused (for example, to stir the measured solution). The electrode should be attached to an electrode holder.

To clean the electrode, it should only be rinsed (with distilled water or buffer solution) and carefully dabbed dry with a clean tissue. The electrode should not be rubbed, as this could give rise to electrostatic forces, which increase the response time of the electrode (see “2.3 How to maintain a reliable signal” on page 30).

2.2.2 Industrial pH measurement

The pH electrode assembly should be mounted in a place where it is easily reached and where defined conditions exists. Unlike laboratory measurements, industrial measurements are mainly continuous (on-line), see "Figure 14 Industrial measuring sites." on page 23. Usually the process occurs in closed stirring vessels (chemical reactors, bio-reactors). Measurements may, however, also be taken in pipelines, basins, or open canals. The process conditions may be very different. In addition to high temperatures and pressures, an electrical current may also have to be considered. An industrial pH electrode assembly consisting of a pH electrode and an electrode housing must be adapted to these circumstances. For industrial processes efficiency is critical. Hence, simple maintenance is of main interest.

The choice of a suitable pH electrode assembly is determined by the installation possibilities. Ideally, a pH electrode assembly should be mounted in a place that is easily reached and where representative and defined conditions of the process exist. In a stirred vessel the electrode assembly is often installed laterally with the aid of a weld-in socket. Flange joints or screw connections are also used. In order to ensure that the glass membrane is always filled with the inner buffer an installation angle of at least 15° above horizontal should be used. It is difficult to install side mounted lateral support fittings in vessels with an inner lining of glass, enamel or rubber. In these vessels pH measurements must therefore be made through the cover with very long electrode assemblies.

Especially in vessels containing solid components the stirring forces have to be considered. A basic principle is to make sure that the pH electrode assembly remains immersed in the solution, independent of the level of the solution. If there are no more free ports available in the cover, the pH value may be measured in a bypass. In this measuring arrangement you have to take a delayed change of the pH value into account. The installation of the bypass system must be done in such a way that clogging does not occur.

A retractable housing has great advantages when installed literally in a pipe-line. The pH electrode may be checked, cleaned, calibrated and replaced without interrupting the process. When installed in a pipe-line, no bypass valves are necessary. The possibility of withdrawing the electrode during the process helps to ensure a correct pH measurement. Retractable pH housings meet the requirements for an automatic pH measuring system. Probes without a retractable function enable the maintenance of an electrode only in combination with an interruption of the process, emptying of the vessel, etc. in pressurized systems.

After having clarified the installation possibilities, the process determines the choice of suitable electrode and housing. Both components of the pH electrode assembly should suit the process requirements.

Electrodes with a liquid electrolyte must be operated with an overpressure, preventing the measuring solution from entering into the reference electrolyte. The overpressure also ensures a constant cleaning of the junction. Housings for liquid electrolyte electrodes therefore possess a pressure chamber and a pressure indicator (see Figure 13 below). Using this type of pH electrode assembly requires control of the overpressure and the periodic inspection of the level of the reference electrolyte. Because of their ability to be refilled, liquid filled electrodes have a long life expectancy if maintained correctly. Also, in the case of difficult measurements a special electrolyte may be used.



Figure 13 InTrac 776e

Electrodes with gel or polymer electrolytes require very little maintenance. Checking the overpressure and the electrolyte level is not necessary. Polymer electrolyte electrodes are pressure resistant and do not need a classical junction due to their special construction; therefore, they are less sensitive to contamination. Electrodes with a gel electrolyte may be supplied with an overpressure. Since their life expectancy is generally good, a gel or polymer electrode is often the most economical alternative due to their low maintenance costs. In addition, the probe can be kept small and simple, since no pressure chamber is needed.

The probe in the probe housing has to have the same corrosion resistance as the reactor. In addition to stainless steel, alloyed materials (e.g. Hastelloy) and plastics (e.g. PVDF) are used.

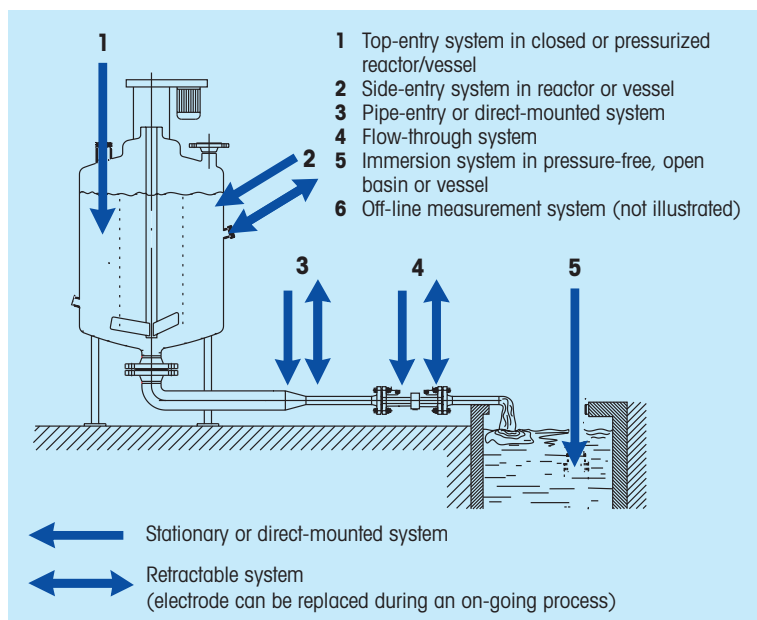

Figure 14 Industrial measuring sites.

2.2.3 Signal processing and environmental influences

The combination electrode provides a potential which is specific for the pH value. This signal has a high resistance. In order to represent it as a pH value, a special transmitter is needed (see Figure 15 below).

The potential of the pH electrode is also influenced by the temperature. Therefore, the pH transmitter offers the possibility of manual or automatic temperature compensation (see "5.6 The influence of temperature on pH measurements" on page 85).

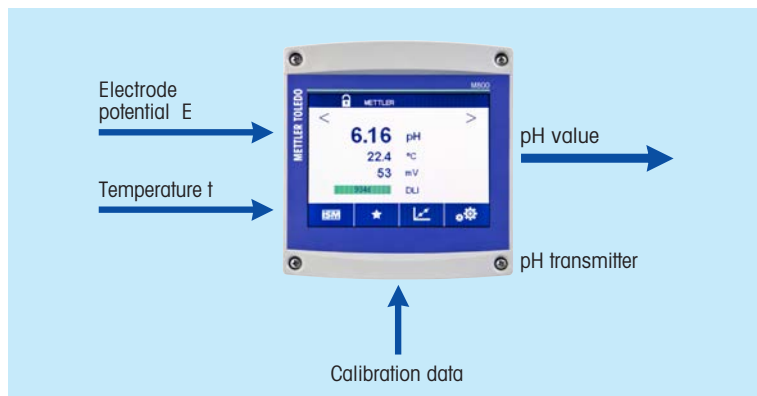

Figure 15 Signal transformation.

Calibration and control

The electrode is characterized by its zero point and its slope. In addition to the two-point calibration (see "2.2.4 Calibration" on page 28), other methods exist which can monitor the performance of the electrode. For instance, a so called one-point calibration may be performed, provided that the slope remains constant.

If a process sample is taken instead of using the buffer solution, and its pH value is measured in the lab, the electrode does not have to be removed from the process. The pH transmitter can be set using the pH value obtained for the sample in the laboratory. However, it has to be taken into consideration that the pH value of the measured solution is a function of different parameters such as temperature, dissolved CO₂ level, completion of reaction, etc.

A second possibility for controlling the system is to determine both the zero point and the slope in the laboratory and subsequently enter the values into the pH transmitter.

Temperature compensation

Automatic temperature compensation is generally used in industry, except when both calibration and pH measurement occur at a constant temperature (see "2.2.3 Signal processing and environmental influences" on page 24). If the process temperature does not differ from room temperature by more than 10 °C, temperature compensation is often not necessary, since the measuring error is less than 0.15 pH units (between pH 3 and 11; see "5.6 The influence of temperature on pH measurements" on page 85).

– Accuracy and reproducibility of measuring values

The main differences between pH measurement in the laboratory and in industry are the frequency of calibration and the accessibility of the pH assembly. The accuracy and reproducibility of the measured values depend basically on the frequency of calibration and maintenance of the electrode.

– Environment

Environmental influences act mainly on the cable and on the pH transmitter. The most important factors are the surrounding temperature, relative humidity, and electromagnetic fields. Hence, in industry protection class IP65 should be observed, as well as a robust design. In industry different hazardous areas may exist. The pH transmitter has to be designed according to the requirements for each safety zone.

– Cable

Since the signals are high impedance, long cables are susceptible to disturbances. At a cable length of over 10 meters a preamplifier is desirable; at a length of over 20 meters, indispensable.

A coaxial cable is used as an electrode connection cable. In the case of strong electromagnetic disturbances (caused, for example, by motors) it is wise to use a triaxial cable (a coaxial cable with an additional shield), for which a correct grounding of the outer shield is needed. The outer shield should be grounded only in one place.

Signal interpretation

For signal conditioning, transmitters are galvanically isolated between input and output to prevent ground loops. This helps to avoid disturbances caused by potential differences between the transmitter ground and the ground potentials in the vessel, reactor, or in the pipe-line. These ground currents will otherwise flow through the reference electrode and appear as a signal error or even destroy the reference system.

These kinds of disturbances are eliminated without exception through galvanic isolation.

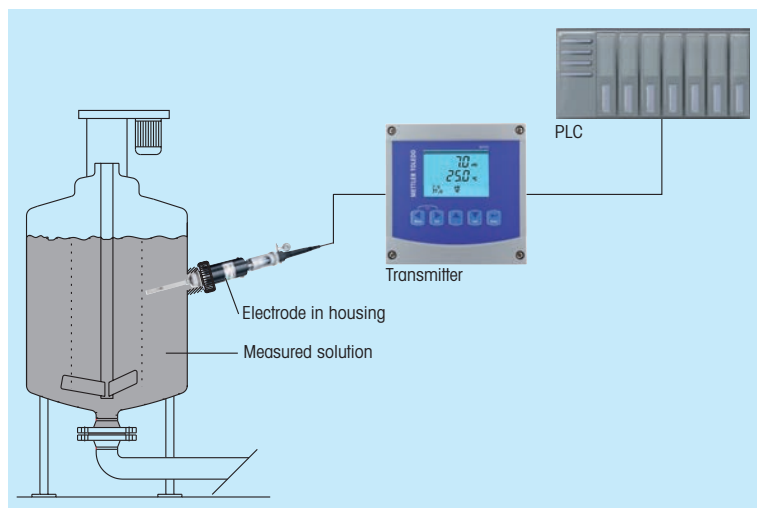

Figure 16 Complete measurement system.

Digital measurement systems

The development over the past decade of digital process analytical measurement systems for pH and other parameters, such as METTLER TOLEDO's Intelligent Sensor Management (ISM™) technology, has brought about significant improvements to sensor operations. These include digital transmission of the measurement signal from the sensor to the transmitter. This eliminates the influence of the aforementioned environmental factors and cable length on signal integrity (see "3 Intelligent Sensor Management" on page 42).

2.2.4 Calibration

Both the zero point, the point where the pH electrode delivers 0 mV-potential and the slope of the calibration line show manufacturing dependent tolerances and will change after exposure to the measuring solutions.

Therefore the pH electrode has to be calibrated with accurately defined buffer solutions. In order to make an exact calibration, the zero point of the measuring chain has to be known. This is generally at pH 7 (see "5.5 Calibration / adjustment of the pH measurement setup" on page 84).

Two buffer solutions chosen according to the desired accuracy and measuring range should be used. The value of the first buffer solution should be close to zero mV (at pH 7). The second buffer solution should have a pH value within the measuring range.

It should be noted that the two buffer solutions must have a difference in pH values of at least two pH units. As already mentioned, the pH value is temperature dependent. Therefore, it is important that the temperature curve of the buffer is known. Additionally, the buffer and the electrode must be at the same temperature, or you must wait for the temperature to reach equilibrium.

The zero point calibration (pH 7, first buffer) always has to take place before the slope calibration (with a pH value close to the measuring value, second buffer) except when working with a microprocessor controlled system.

If a very accurate measurement is required, it is advisable to repeat the zero point calibration after the slope calibration.

The following factors directly influence the accuracy of the calibration as well as the pH measurement:

- Buffer solutions
- Temperature measurement and temperature compensation
- Condition of the junction and the reference system (contamination, etc.)
- Working technique

The stability of the zero point and the slope depends on the composition of the measuring solution as well as on the temperature. It makes little sense to make general statements regarding the calibration frequency. Therefore, when working with unknown solutions it is advisable to repeat the calibration often in the beginning.

When the calibration values are stable, the calibration frequency may be extended. In general the calibration frequency depends on the desired accuracy. To be able to calibrate during the process, an electrode in a retractable housing is very useful.

2.2.5 Buffer solutions

For extremely accurate measurements National Institute of Standards and Technology (NIST) buffer solutions are recommended. These buffer solutions are the basis of the practical pH scale and have been adapted in the DIN 19266. However, they are almost exclusively used in the laboratory. Buffers customarily used (e.g. potassium dihydrogen phosphate and disodium hydrogen phosphate, borax or sodium carbonate) are distinguished by their high buffer capacity and long-term stability. These buffer solutions are used in most cases and should have an accuracy of not less than 0.02 pH units. The temperature curve of the buffer solution must be known.

Buffer solutions last for a limited period of time. (Sealed bottles last for about one year when stored correctly). Using good lab practice should prevent buffer contamination. Carbon dioxide from the air may contaminate buffer solutions with a high pH value.

Most modern transmitters will feature stored temperature curves for a range of buffers.

2.3 How to maintain a reliable signal

The pH electrode is an electrochemical sensor whose efficiency depends on a reversible interaction between the sensor and the measuring solution.

The accuracy of the signal is decreased when residue on the glass membrane or reactions of the reference system disturb this exchange.

2.3.1 Maintenance of the electrode function

An increase in response time of the electrode, a decrease of the slope, or a zero point shift, are all phenomena due to either a reaction with the measuring solution (contamination) or to the ageing of the electrode.

Every electrode ages as a result of the chemistry of the glass even when it is not used for measurements. High temperatures increase this ageing process. Under laboratory conditions a life span of up to three years can be expected, With continuous measurements at 80 °C, the life span of an electrode could be significantly decreased (perhaps to a few months).

If a reaction between the measuring solution and the electrolyte causes disturbances, using an electrode with a silver-ion trap reference system, an electrolyte bridge, and/or a special electrolyte often improves conditions (see Figure 17 on page 32).

How to avoid contamination:

- Periodic rinsing of the electrode with a suitable solvent.
- If the risk exists that solids may be deposited on the surface of the membrane they can be removed by increasing the stirring or flow velocity respectively.

The electrode should be cleaned when the junction or the glass membrane is contaminated. Depending on the type of contamination, different cleaning methods are recommended:

Measuring solutions containing proteins: (contamination of the junction)	The electrode is soaked in pepsin/HCl for several hours
Measuring solutions containing sulfides (black junction)	The junction is soaked in urea/HCl solution until bleached
Lipid and other organic measuring solutions	Short rinsing of the electrode with acetone and ethanol
Acid and alkaline soluble contaminations	Rinsing the electrode with 0.1 mol/L NaOH or 0.1 mol/L HCl for a few minutes

After these treatments the electrode has to be soaked in the reference electrolyte for 15 minutes. Also a recalibration has to be done before any new measurements can be carried out, since the cleaning solution diffuses into the junction during the cleaning procedure, and may cause diffusion potentials.

The electrode should only be rinsed and never rubbed or otherwise mechanically cleaned, since this would lead to electrostatic charges. This could cause an increase in the response time.

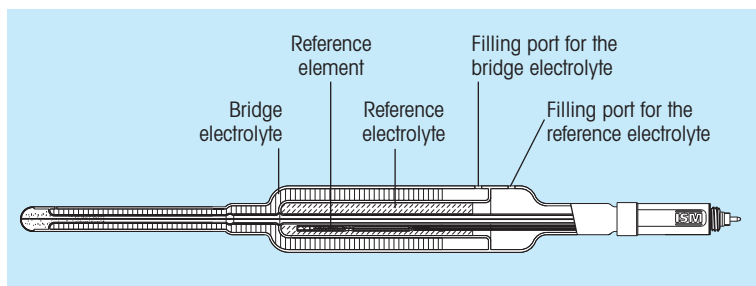

Figure 17 Electrode with built-in electrolyte bridge.

Refill of electrolyte

The reference electrolyte has to be refilled or changed when:

- the conducting element of the reference electrode is no longer completely immersed in the electrolyte (because of the diffusion of the electrolyte through the junction).
- the reference electrolyte is contaminated (because of intrusion of the measuring solution).
- the concentration of the reference electrolyte has increased through water evaporation.

Please note that only the electrolyte referred to on the electrode should be used.

Pressure compensation for liquid filled electrodes

When measuring in a vessel or in a pipeline, the reference electrolyte is kept under a slight overpressure in order to avoid contamination by the measured solution. This procedure is only possible (and necessary) when using an electrode with a liquid electrolyte.

2.3.2 Storage

Electrodes should always be stored in the reference electrolyte. This allows immediate use of the electrode and ensures a short response time.

When stored dry for long periods, many electrodes must be reactivated by soaking for several hours before use in order to get optimal measuring results. If these measures are not sufficient the electrode may be made functional by treating it with a special reactivation solution followed by subsequent conditioning in the reference electrolyte (e.g. overnight). If stored in distilled water the electrode will have a longer response time.

2.3.3 Temperature compensation

The pH range (0-14) is determined through the ion product of the water, which to a very small extent dissociates into H^+ and OH^- ions.

$$[H^+] [OH^-] = 10^{-14} = I \text{ (25 °C)}$$

The ion product I is strongly dependent on temperature.

The temperature influences the pH measurement through four factors:

- Chemical equilibria are temperature dependent
- Temperature dependence of the slope (see Nernst equation below)
- Position of the isothermal intersection
- Differing response time of the electrode (caused by temperature changes).

Every measuring solution has a characteristic temperature and pH behaviour (temperature coefficient). In general you should assume that a temperature change results in a pH change (see buffer/temperature table below). The reason for this is the temperature dependent dissociation which causes a change in the H^+ concentration. This pH change is real, not a measuring error.

Buffer/temperature table

Example:

	20 °C	30 °C
0.001 mol/L HCl	pH 3.00	pH 3.00
0.001 mol/L NaOH	pH 11.17	pH 10.83
phosphate buffer	pH 7.43	pH 7.40
Tris buffer	pH 7.84	pH 7.56

This has to be taken into consideration if pH values obtained by different temperatures are to be compared.

The most exact pH value is obtained when the temperature of the calibration and measured solutions are identical.

Furthermore, the slope depends on the temperature (Nernst equation):

$$E = E_0 - 2.303 RT/F \times \Delta \text{pH} \quad (R, F = \text{constant})$$

- Where:**
- E = measured potential
 - E_0 = zero point potential
 - ΔpH = difference in pH between outside and inside of the glass membrane
 - F = Faraday constant
 - R = universal gas constant
 - T = temperature Kelvin

the slope increases with an increase in temperature (see "5.6 The influence of temperature on pH measurements" on page 85).

The temperature compensation of the transmitter corrects for this effect. An electrode would have an ideal temperature behavior if its calibration lines (isothermals) intersect at the zero point of the electrode (pH 7 = 0 mV) at different temperatures (see Figure 18 below).

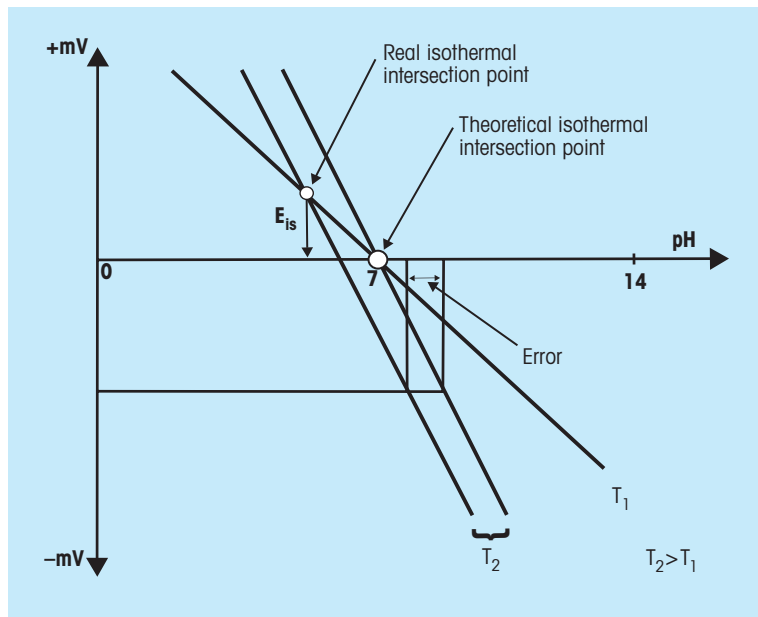

Figure 18 Calibration line and isothermal intersection points.

Since the overall potential of the pH electrode is composed of the sum of many single potentials, which all have their respective temperature dependencies, the isothermal intersection hardly ever coincides with the zero point of the electrode (the ideal case would be: 0 mV at pH = 7 / 25 °C).

In the last few years, the development of the electrode has concentrated on bringing the isothermal intersection and the zero point as close together as possible, since the nearer they are to pH 7 the smaller the error in the temperature compensation. Besides, the measuring error increases with an increasing temperature difference be-

tween the calibration and the actual measuring. As a rule the errors are in the order of 0.1 pH units (see "5.6 The influence of temperature on pH measurements" on page 85).

Temperature/time behavior of combination electrodes

When the temperature change of the medium is rapid, a conventional pH electrode will drift until the temperature of the electrode and the medium become equal. In order for a combination electrode to react rapidly to the temperature changes of the medium, the temperature of the inner lead-off element and the outer reference element must always be identical. Alternatively the temperature dependence of the lead-off elements have to be equal to zero.

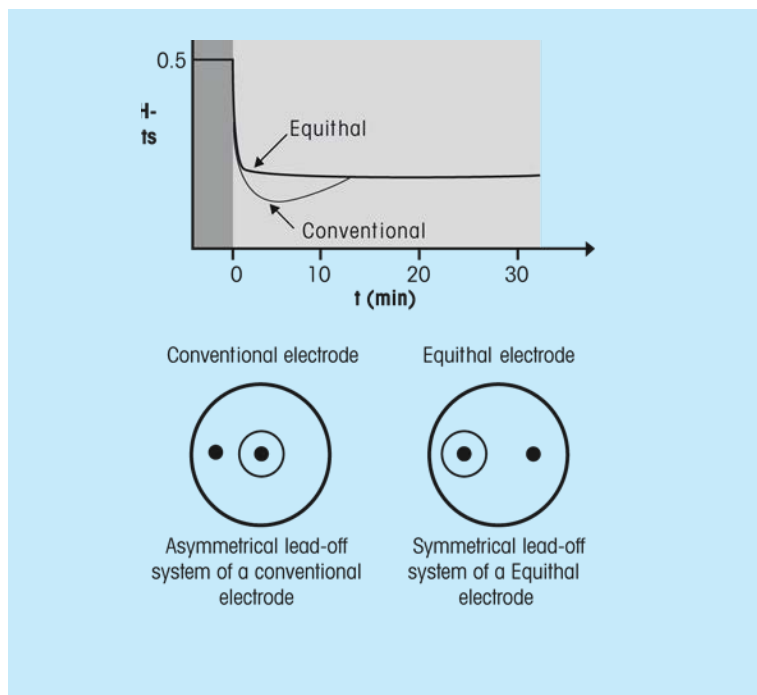

Figure 19 Symmetrical structure of an Equithal™-system in comparison with a conventional electrode.

Optimal electrodes are above all distinguished by the symmetrical warming up or cooling down of their lead-off elements. They have the same temperature coefficient and isothermal Intersection at pH 7 and 0 mV.

Thereby a short response time to temperature changes, as well as an accurate temperature compensation can be guaranteed (see Figure 19 on page 36).

2.4 Troubleshooting

The troubleshooting diagram on page 38 should help the user to find and eliminate an error or at least restrict the possible causes.

In the diagram the most frequent errors were considered. The diagram is designed for troubleshooting industrial measuring systems.

2.4.1 Instructions and comments for the troubleshooting diagram

As a starting point for this diagram, the following situation has been chosen:

- The on-line measurement differs from a comparison measurement in the lab.
- After that, the electrode used in the on-line measurement has to be calibrated (see "2.2.4 Calibration" on page 28 and "5.5 Calibration / adjustment of the pH measurement setup" on page 84). The beginning of the troubleshooting diagram is «start».

Important: be sure to use correct buffer solutions to calibrate (see chapters "2.2.4 Calibration" on page 28 and "5.3 Buffer solutions" on page 75).

Troubleshooting diagram

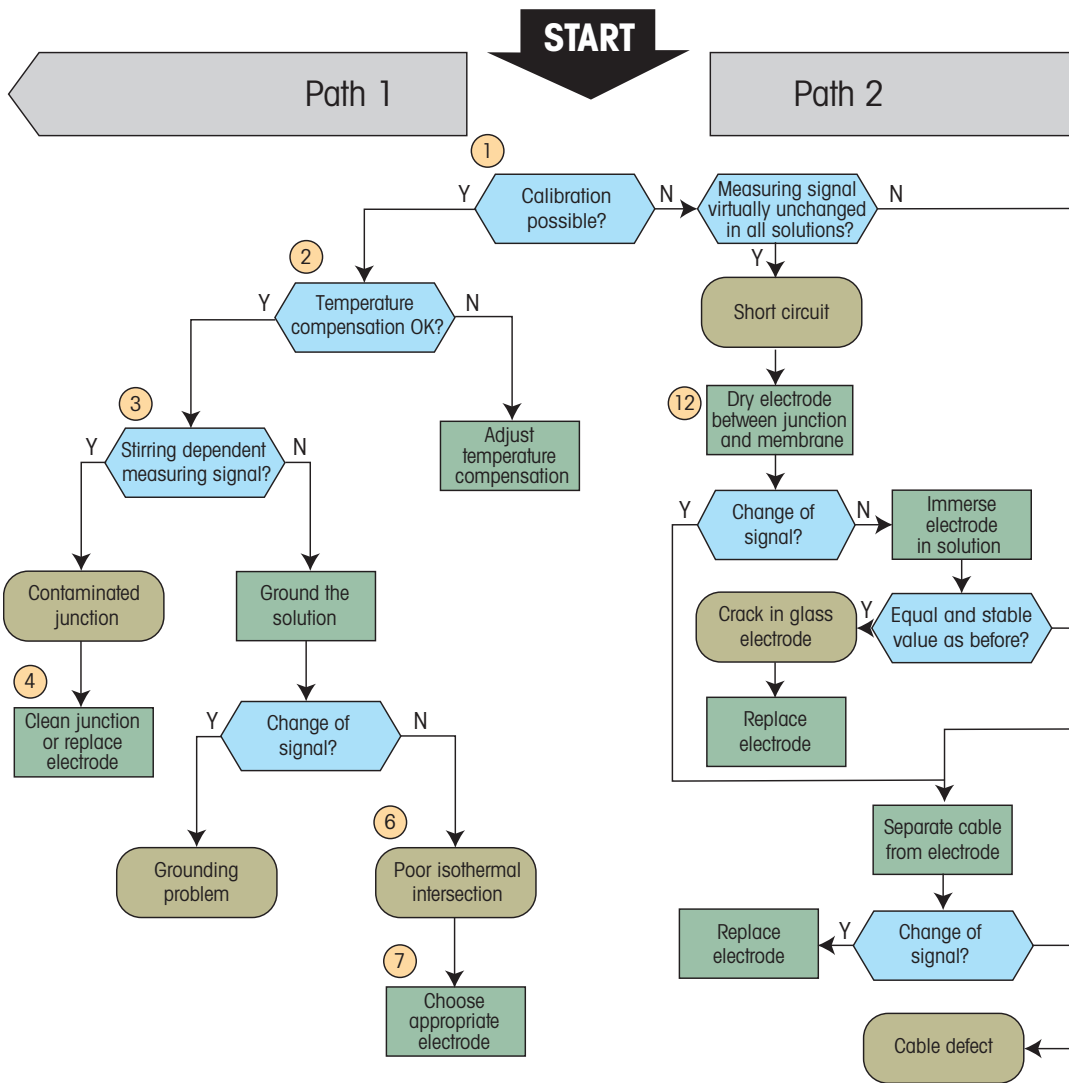

Instructions for use:

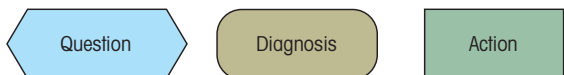
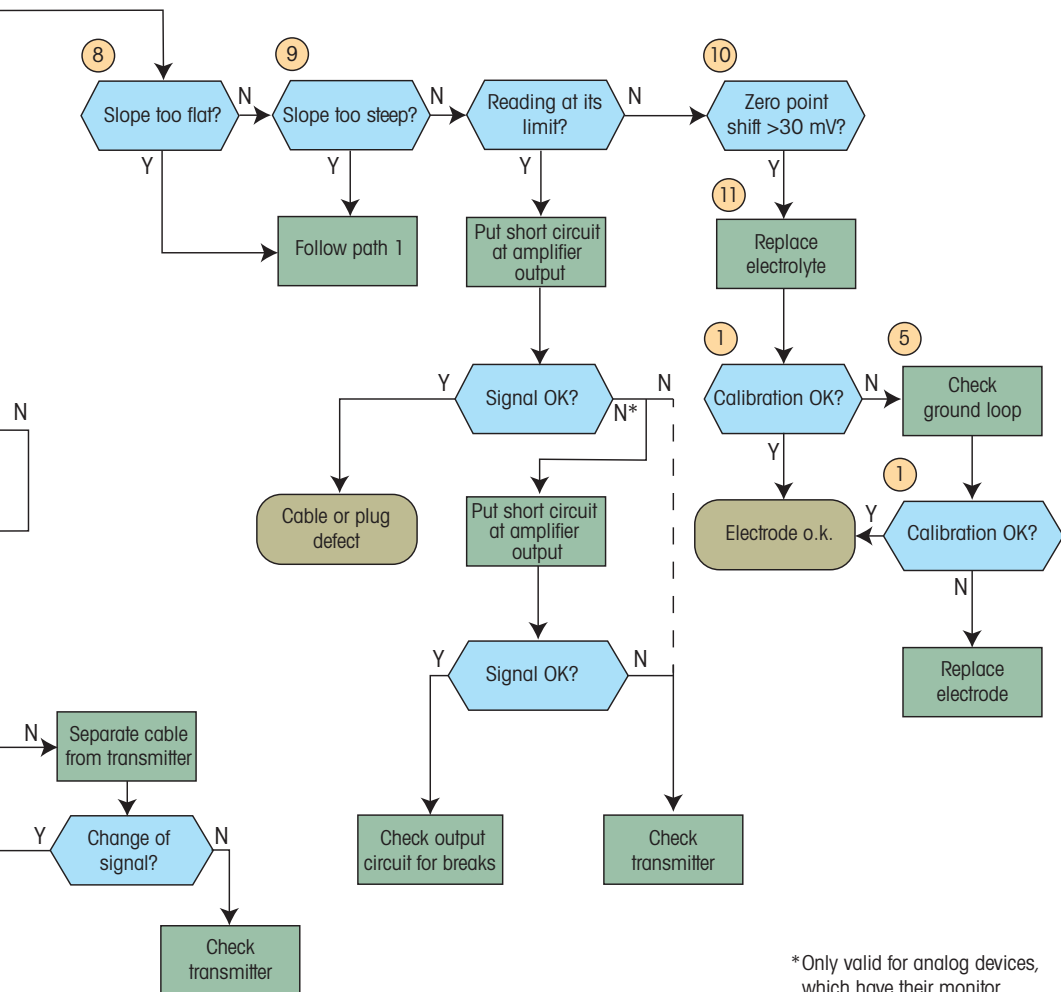

Figure 20 Troubleshooting diagram



*Only valid for analog devices, which have their monitor connected to the output circuit. Otherwise follow: N - - - ➔

When an error has been removed, go back to <<start>> again in order to find further possible errors. The following explanations have been numbered according to the numbers in the boxes of the diagram:

- 1 The question "calibration possible" can be answered with yes if the pH monitor allows the necessary corrections of the zero point of the electrode and the slope. Many devices must have a slope of the electrode of at least 85 % and at most 102 % The zero point should not be more than ± 30 mV from the theoretical value (DIN standard). Only under these conditions can the calibration be done (see "2.2.4 Calibration" on page 28 and "5.5 Calibration / adjustment of the pH measurement setup" on page 84).
- 2 Temperature compensation OK: is the temperature of the pH monitor correct, the temperature of the buffer solution correctly adjusted? Are the temperature sensors, when using automatic temperature compensation, in the same solution (buffer) as the electrode?
(See "2.3.3 Temperature compensation" on page 33 and "5.3 Buffer solutions" on page 75)
- 3 A signal is said to be stirring-dependent if it changes when the stirring velocity changes (or when the velocity of the medium passing through a pipe line changes). Please notice that low ionic strength measuring solutions may show a stirring-dependent measuring signal independent of junction contamination.
- 4 See "2.3.1 Maintenance of the electrode function" on page 30.

- 5 See "2.2.3 Signal processing and environmental influences" on page 24.
- 6 An incorrect isothermal intersection may cause measuring errors if the measuring temperature differs strongly from the calibration temperature (see "2.3.3 Temperature compensation" on page 33 and "5.6 The influence of temperature on pH measurements" on page 85).
- 7 Contact the electrode manufacturer
- 8 "Slope too flat" means that the slope cannot be adjusted with the applied device (when the slope is 85 % or less of the theoretical value).
- 9 "Slope too steep" means that the slope cannot be adjusted with the applied device (when the slope is 102 % or more of the theoretical value).
- 10 Some devices allow a zero point correction of more than ± 30 mV (± 0.5 pH; 25 °C). According to DIN standards, however, the zero point should not differ from the theoretical value by more than ± 30 mV.
- 11 Please note: Only electrolytes recommended and supplied by the electrode manufacturer for the corresponding electrodes should be used to refill the electrode.
- 12 An artificial interruption (open circuit) is produced between the glass and reference electrode.

3 Intelligent Sensor Management

The most significant development in recent years in pH measurement has been the introduction of digital measurement systems. These allow a number of sensor installation, measurement, calibration, and maintenance advantages that analog systems cannot provide. METTLER TOLEDO's Intelligent Sensor Management (ISM) platform is one such technology. ISM simplifies sensor handling, enhances process reliability, and reduces sensor lifecycle costs. Central to ISM is the inclusion of a microprocessor in the sensor head. It is this feature that permits ISM's many benefits.

3.1 Signal integrity

As mentioned earlier in this guide, pH sensors transmit a high impedance mV signal to a transmitter which converts the signal to a displayed pH level. Environmental influences such as humidity and electromagnetic interference from surrounding equipment, plus the length of cable from sensor to transmitter, can negatively impact the integrity of the signal. In ISM sensors, the pH level is calculated in the sensor's microprocessor. Due to the proximity of the pH and reference electrodes to the microprocessor, the measured pH level is more accurate than in analog systems. The digitized signal is then transmitted over coaxial cable to the transmitter for display and/or forwarding to a PLC system. Being digital, the signal is unaffected by environment and cable effects; therefore, the signal integrity of ISM systems is extremely high. This makes ISM systems particularly suitable for processes where the sensor and transmitter are far apart, and processes where there is a lot of moisture present in the environment.

3.2 Pre-calibration

A further advantage of ISM is the storing of sensor calibration data on the sensor's microprocessor. This means that sensors can be calibrated, using computer software (see ISM Core™ below) or an ISM-equipped transmitter, in a convenient location and then stored until they are required. This feature is particularly useful, for example, in the biopharmaceutical industry where taking calibration fluids into a clean-room presents a contamination risk, or in chemical processes where there exists a potential health risk to employees.

Further, when connected to the transmitter, due to the calibration and other configuration data held on the sensor, the new probe is instantly recognized and the system is ready to measure in under a minute. This Plug and Measure feature not only significantly reduces the time for which a measurement system cannot be used, it eliminates the risk of incorrect calibration data being entered into transmitters, therefore increasing process reliability.

3.3 Predictive diagnostics

During batch processes, the failure of a measuring sensor can be hugely detrimental. Ideally, operators want to know that a sensor will operate correctly until the batch is complete. ISM technology is able to provide expert diagnostic information that is particular to each measurement point. This information is available to operators via the display on ISM-equipped transmitters, or can be sent to the PLC.

The diagnostic tools allow a measurement point to be optimized on an ongoing basis and all critical situations to be predicted so that operators can respond before production is interrupted.



Dynamic Lifetime Indicator

The DLI estimates in real time the remaining lifetime of the sensor. A unique algorithm uses current and historic measurement and calibration values to calculate the remaining lifetime of pH electrodes.



Adaptive Calibration Timer

Based on the DLI, the ACT calculates when the next electrode calibration will be required.



Time to Maintenance

The electrode also indicates when the next maintenance should be performed.



CIP/SIP Counter

CIP and SIP cycles are interpreted with a proprietary, patented algorithm.

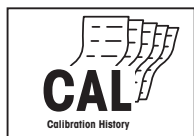

Calibration History

Calibration history is stored in the electrode and can be used for diagnostics.

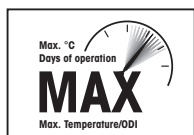

Maximum Temperature

Maximum Temperature/Operating Days Indicator. Information about the maximum temperature the sensor has ever been exposed to and the number of operating days.

3.4 Asset management software

ISM Core is computer software for use with ISM sensors. ISM Core provides a number of functions including sensor calibration, electronic documentation, and management of all the ISM sensors at a facility. ISM Core runs on PCs and laptops and is designed to be used where sensor maintenance is most convenient. In chemical industry applications this could be in a workshop or maintenance room which is close to the production environment. In the pharmaceutical industry, a laboratory room would be very suitable.

Calibration

Calibrating ISM pH electrodes using ISM Core is a straightforward and quick process. Once completed, the calibration data is automatically recorded in the history for the particular electrode. Calibrated probes can then be stored until they are needed. Now when pH electrode replacement is necessary it is a simple matter of taking a pre-calibrated probe from stock and a quick exchange at the measuring point. No further calibration is required. There are no buffers at the process and no risk of process contamination. ISM Core also contains a buffer database which can be added to if required.

In addition, the digital nature of ISM allows for a very accurate calibration to be performed, which results in more reliable measurements and excellent repeatability.

3.4.1 Electronic documentation

For the pharmaceutical and biopharmaceutical industries, meeting stringent regulations includes being able to supply accurate records on the calibration history of process analytical sensors used at the facility. The time taken for technicians to transfer written notes to a PC can be considerable, and there is always the possibility of human error in the data transfer.

With ISM Core, a record of an electrode's calibration and maintenance history is automatically stored in the internal database. Additionally, data on maximum temperature exposure, operating time, number of CIP/SIP cycles, etc. are also uploaded from the sensor to ISM Core. All this data can be documented electronically or printed from a PDF.

A user management and electronic logbook allows control and tracking of all activities ensuring a complete record of pH electrode assets over their lifetime.

3.4.2 Sensor management

Every time an ISM pH electrode is connected to ISM Core, the software's Key Performance Table tells you if the electrode is "healthy". The data shown is appropriate for the electrode type and provides the most essential information, including sensor condition and history (e.g. exposure to CIP/SIP cycles). A smiley is shown on the screen to provide an at-a-glance indicator of sensor state.

The key to effective sensor management with ISM Core, is the Dynamic Lifetime Indicator (DLI) mentioned above. The unique algorithm behind the DLI distills METTLER TOLEDO's many years of experience regarding the influence of process environment and maintenance (e.g. temperature, pH level, calibrations) on electrode lifetime and compares this historical data with the current process conditions. From this information the DLI produces a real-time display of remaining electrode life. By monitoring the condition of ISM assets you are able to ensure you always have sufficient stock of healthy sensors.

When the DLI indicates that an electrode can no longer be used, for process security ISM Core can disable the sensor and issue a deactivation report. If a deactivated electrode is accidentally connected at a measuring point, the transmitter will recognize that the probe has been disabled and it will not be accepted.

A complete view of all electrode data is provided by an SQL database allowing you to access all previously stored data of all ISM sensors used at your facility. Unlimited data export opens new possibilities for optimizing measurement systems and processes, as well as maintenance management of the installed sensor base.

4 Electrode selection and handling

For optimal pH measurements, the correct electrode must first be selected. The most important sample criteria to be considered are: chemical composition, homogeneity, temperature, process pressure, pH range and container size (length and width restrictions). The choice becomes particularly important for non-aqueous, low conductivity, protein-rich and viscous samples where general purpose glass electrodes are subject to various sources of error.

The response time and accuracy of an electrode is dependent on a number of factors. Measurements at extreme pH values and temperatures, or low conductivity may take longer than those of aqueous solutions at room temperature with a neutral pH.

The significance of the different types of samples is explained below by taking the different electrode characteristics as a starting point. Again, mainly combination pH electrodes are discussed in this chapter.

4.1 Different kinds of junction

4.1.1 Ceramic junctions

The opening that the reference part of a pH electrode contains to maintain the contact with the sample can have several different forms. These forms have evolved through time because of the different demands put on the electrodes when measuring diverse samples. The “standard” junction is the simplest one and is known as a ceramic junction. It consists of a porous piece of ceramic which is pushed through the glass shaft of the electrode. This porous ceramic material then allows the electrolyte to slowly flow out of the electrode, but stops it from streaming out freely.

This kind of junction is very suitable for standard measurements in aqueous solutions; the METTLER TOLEDO **InPro 325x** series is an example of such an electrode. A schematic drawing of the principle of this junction is shown in Figure 21 below.

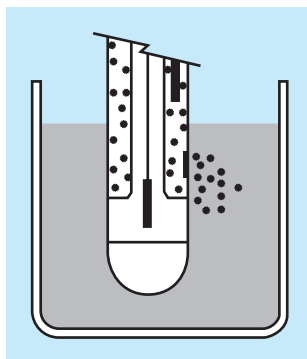

Figure 21 Electrode with ceramic junction.

Even though this is probably the most widely used junction because of its simplicity of use with aqueous solutions, it has one main drawback: Because of the porous structure of the junction it is relatively easy for samples to block the junction, especially if the sample is viscous or if it is a suspension.

You also have to be careful with some aqueous samples such as those with a high protein concentration, since proteins may precipitate within the porous junction if they come in contact with the reference electrolyte, which is often KCl. This reaction will cause the porous structure to be filled with protein debris blocking the junction and rendering the electrode useless. Measurements are not possible if the electrolyte cannot flow freely since the reference potential will no longer be stable.

The same problem can also be caused if the inner electrolyte reacts with the sample solution being measured and the two meet in the junction. This reaction can create a precipitate which may block the junction, for example if KCl electrolyte saturated with AgCl is used with samples containing sulfides, the silver and sulfides react to form Ag_2S which then blocks the ceramic junction. Factory-filled, prepressurized liquid/gel electrolyte pH electrodes are suited to a wide scope of applications in the biotechnology, pharmaceutical and chemical process industries. This ensures the best possible measurement performance under the most diverse operating conditions.

4.1.2 PTFE annular diaphragm

An annular PTFE diaphragm instead of a ceramic pot increase the surface to the media to prevent clogging on the diaphragm. PTFE is a dirt-repelling material.

Highly contaminated process conditions makes pH measurement and control a complicated issue. An annular PTFE reference diaphragm (e.g. METTLER TOLEDO's InPro 480x series) is designed for service in tough environments. It resists fouling from hydrocarbon contaminants and sulfides, ensuring high accuracy and fast response throughout its long life. For process media containing particles and aggressive chemicals, the optional flat glass membrane electrode is the optimal solution.

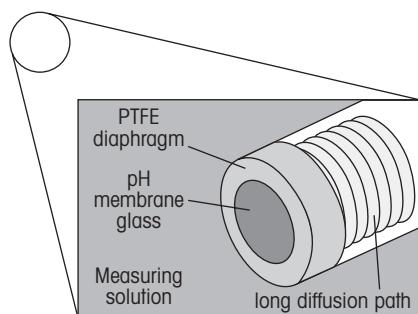

Figure 22 Example of electrode with PTFE diaphragm.

4.1.3 Open junctions

The third type of junction is the open junction. This reference electrode is completely open to the environment and has full contact between the reference electrolyte and the sample solution. This is only possible with a solid polymer reference electrolyte. A schematic diagram of this junction is shown below.

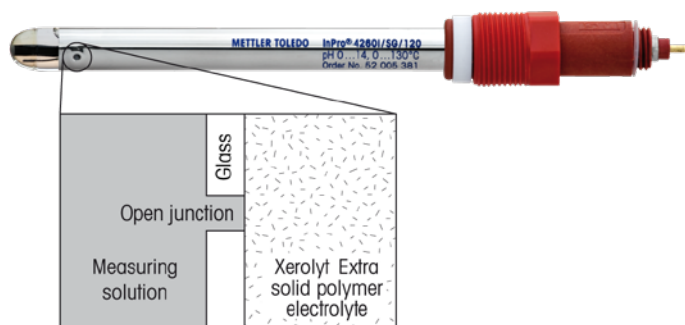

Figure 23 Example of electrode with open junction.

The great advantage of this junction is clearly the fact that it is completely open and therefore is unlikely to clog. Open junctions can easily cope with very dirty samples constantly providing good measurements. The disadvantage of the solid polymer reference electrolyte which is used for this open junction is that it has slower reaction times and low electrolyte flow. This means that the samples measured need to have a high enough ion concentration for stable measurements to be possible. Nevertheless, these electrodes are suitable for most samples and are very robust.

4.1.4 Dual-membrane without junction

The cell membrane chlor-alkali process is very tough on conventional pH electrodes. It exposes them to high temperatures, and clogging and poisoning from a variety of compounds. This is particularly true in the anode side of the electrolysis cell. Chlorine diffuses through the electrode's diaphragm and attacks the reference system. This results in incorrect pH measurement and shorter sensor lifetime.

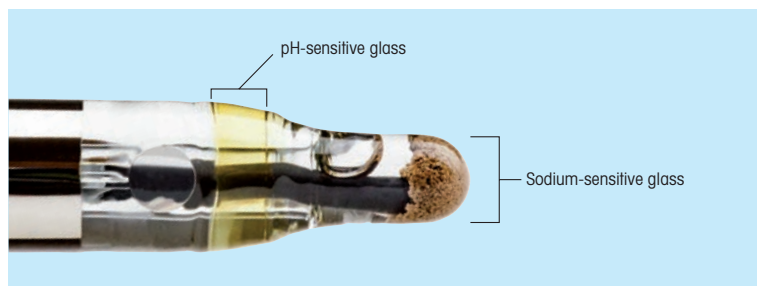

Figure 24 Dual-membrane pH electrode.

Reliable pH measurement can be achieved with sensors such as the InPro 4850 i from METTLER TOLEDO. This is a dual-membrane pH electrode that has been designed to provide long-term accurate measurement in chlor-alkali processes. The main difference in measuring technology between dual-membrane pH electrodes and conventional pH electrodes is the presence of a sodium-reference (pNa) system. The electrode features a sodium-sensitive glass membrane which is charged by the sodium ions in the process medium. The sodium concentration in the brine is used as a reference. The pNa reference system is hermetically sealed; there is no diaphragm, therefore no oxidants can enter the electrode and attack the reference system. The electrode also features a high-alkali resistant pH membrane glass for pH measurement. It is the amalgamation of pH measurement and pNa reference that is one reason that this kind of electrode is highly suited to chlor-alkali processes.

4.2 Reference systems and electrolytes

Of all the possible reference systems developed for reference elements, only a few are of practical importance. These are the silver/silver chloride, iodine/iodide and the mercury/calomel systems, as well as some of their adaptations. Due to environmental considerations, however, the calomel reference electrode is no longer widely used. Here we only discuss the most important reference system, the silver/silver chloride system.

The potential of the reference electrode system is defined by the reference electrolyte and the reference element (silver/silver chloride). The conventional construction of this reference system is a silver wire coated with AgCl. For this version of the Ag/AgCl reference system it is important that the reference electrolyte has a very high (saturated) AgCl concentration to ensure that the reference element wire does not get stripped of the AgCl. If this were to happen the reference element would stop working.

An improvement to this type of reference element was made with the development of the Argenthal reference element. The Argenthal reference element consists of a small cartridge filled with AgCl particles that provide the silver ions for the chemical reaction at the lead off wire. This cartridge contains enough AgCl to last the lifetime of the electrode.

Which type of reference electrolyte is used in an electrode strongly depends on the reference system and on the type of sample used.

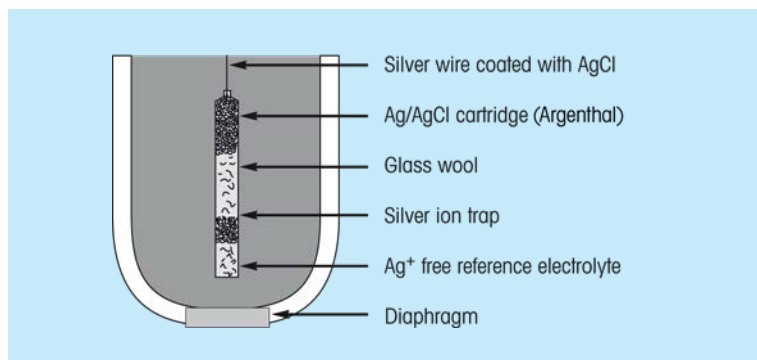

Figure 25 Schematic drawing of the Argenthal reference system.

Whereas the reference system can either be conventional silver wire or Argenthal, the sample can be divided into two classes namely aqueous and non-aqueous matrices.

For both aqueous and non-aqueous solutions it is important that the reference electrolyte contain plenty of ions to keep the reference system working well. Ideally, the salts used to provide these ions in the refer-

ence electrolyte are very soluble in the solvent, are pH neutral (so that they do not influence the measurements when flowing out of the electrode) and do not precipitate out by reacting with other ions present in the sample or buffer. KCl matches these requirements best for aqueous solutions and LiCl is best suited for use with non-aqueous solutions.

The conventional Ag/AgCl reference system needs the presence of an electrolyte saturated with AgCl (see Figure 25 on page 53) so that the lead off wire does not get stripped of AgCl. The reference electrolyte of choice is therefore, 3 mol/L KCl saturated with AgCl. The disadvantage of this electrolyte is that silver ions can react with the sample to form an insoluble precipitate thereby blocking the junction.

As mentioned previously, the Argenthal reference system has a cartridge with AgCl granules which ensure that AgCl is constantly available. Typically, this Argenthal system comes in combination with a silver-ion barrier which stops silver ions from passing into the electrolyte. The advantage of these features of the Argenthal reference system is that you can use standard 3 mol/L KCl as a reference electrolyte rather than 3 mol/L KCl saturated with AgCl, so in combination with the silver-ion trap there are no free Ag^+ ions in the electrolyte which could cause a precipitate after reaction with the sample.

A phase separation in the contact area between electrolyte and sample solution at the junction can cause an unstable signal, therefore deionized water is used as a solvent for the reference electrolyte in aqueous samples, and ethanol or acetic acid is used as solvent for non-aqueous systems.

A brief overview of the possible reference system/electrolyte combinations is given below:

Electrolyte for aqueous samples		Electrolyte for non-aqueous samples
Argenthal	Conventional	Argenthal
3 mol/L KCl + H ₂ O	3 mol/L KCl + AgCl + H ₂ O	LiCl + Ethanol/ LiCl + Acetic acid

In addition to the above-mentioned liquid electrolytes, there are also gel and solid polymer electrolytes. Electrodes delivered with these electrolytes cannot be refilled.

The electrode response time is strongly dependent on the type of electrolyte used. Liquid electrolyte electrodes show a very quick response time and give the most accurate measurements. Gel and solid polymer electrolyte electrode both have longer response times, but they are virtually maintenance-free.

4.3 Types of membrane glass and membrane shape

The pH glass membrane of an electrode can have several different shapes and properties, depending on the application the electrode is used for. The selection criteria here are sample consistency, volume and temperature, the required measurement range and the concentration of ions present in the sample.

The most obvious property is the shape of the membrane, and in Figure 26 below a selection of membrane shapes is shown together with their properties and proposed usage.

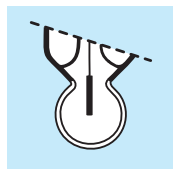

Spherical

For low temperature samples: resistant to contraction



Hemispherical

Small sample volume: pH membrane only on the bottom

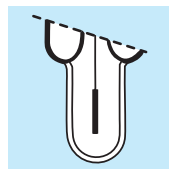

Cylindrical

Highly sensitive membrane: large surface area, lower resistance

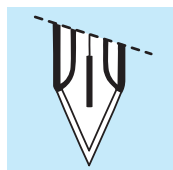

Spear

For semi-solid and solids: punctures the sample easily

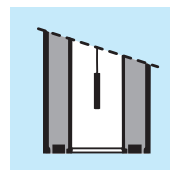

Flat

For surfaces and drop sized samples: very small pH-membrane contact area

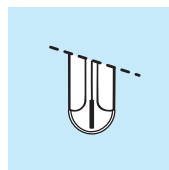

Micro

Samples in reaction tube: very narrow electrode shaft

Figure 26 Differently shaped pH membranes.

The membrane glass is also important for the measurement properties of the electrode. The table below gives an overview of the various types of METTLER TOLEDO pH membrane glasses.

Type of membrane glass	Properties/samples
HA: High alkali glass	For high temperatures and high pH values: extremely low alkali error
LoT: Low temperature glass	For low temperatures and low ion concentrations: low resistance glass
A41	For high temperatures; resistant to chemicals
HF: Hydrofluoric acid-resistant glass	For samples containing hydrofluoric acid (up to 1g/L)
Na: Sodium-sensitive glass	Only used for sodium detecting electrodes: sodium specific glass

The HF membrane glass electrode is more robust in solutions with hydrofluoric acid than standard pH electrodes. Hydrofluoric acid above certain concentrations ($> 1\text{g/L}$) and below pH 5 attacks glass and prevents the development of a gel layer on the standard pH glass membrane. This again leads to unstable measurement values and also reduces the life span of the electrode.

4.4 pH electrodes for specific applications

Now that we have seen what different types of junctions, electrolytes and membranes exist in pH electrodes, we will have a look at what this means for the measurement of the pH in different systems.

4.4.1 Highly accurate problem solver

A highly accurate problem solver pH electrode is sufficient for routine measurements in most applications where a lot of aqueous solutions are tested. The advantage of this kind of pH electrode is that it is very easy to use and is also very robust. In general, these electrodes are made of glass and have a ceramic junction. They are also refillable, which means that you can refill the electrolyte thereby cleaning the electrode and prolonging its lifetime. For example, an electrode of choice for these simple measurements is the **InPro 200x (i)**.

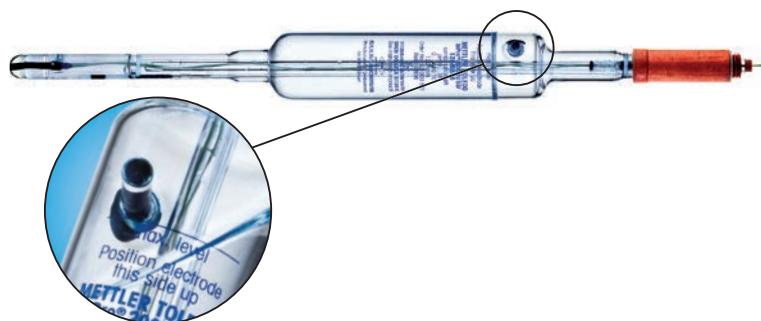

Figure 27 InPro 200x (i)

4.4.2 Complex samples or such of unknown composition

Measuring the pH of complex samples can be somewhat tricky, since dirt in the sample can hinder correct measurements. Examples of such applications are soil acidity measurements, quality control in foodstuffs such as soups and measurements in colloidal chemical systems. The risk of blockages with such samples would be very high if you were to use a pH electrode with a ceramic junction. Therefore it is best to use a pH electrode with an open junction such as the **InPro 426x** which has a solid state polymer reference electrolyte **Xerolyt™ Extra**. This electrode has a hole in the shaft which allows direct contact between the electrolyte and sample.



Figure 28 InPro 426x (i)

It offers the following advantages:

- Insensitivity to flow variations.
- Especially adapted for low ionic content media and organic solvents.
- Particularly insensitive to anionic salt contents such as nitrate, sulfate, carbonate.
- Dual-open junction between sample medium and reference electrolyte (no diaphragm means no clogging) allows reliable measurements in heavily contaminated process media, in suspensions and emulsions, and in solutions containing protein.
- Particularly efficient in sulfide-bearing media.

4.4.3 Semi-solid or solid samples

Standard pH electrodes are generally not able to withstand the pressure of being pushed into a solid sample; therefore you need a special electrode which is able to penetrate the sample in order to measure the pH. The shape of the membrane is also important as it needs to be formed in such a way as to ensure a large contact area with the sample, even if the electrode is pushed into the sample with force.

The METTLER TOLEDO electrodes most suitable for these kinds of applications are the **Puncture pH Electrodes**. While their spear-shaped point enables them to pierce the sample, the membrane shape ensures accurate measurements. The **Puncture pH Electrode** also has an open junction, which further prevents the junction from being blocked by the (semi-) solid sample. This electrode is typically used for quality control or checking production processes of cheese and meat.



Figure 29 Puncture pH electrode

4.4.4 At the toughest applications in chemical process industries

With a long diffusion path, pH electrodes can be highly resistant to oxidizing media, solvents, and acid or alkali solutions, and they enable operation at particularly high process pressures. A dirt repellent annular junction (PTFE) can prevent the dirt clogging on the diaphragm surface.

METTLER TOLEDO's **InPro 480x** offer reliable measurements in oxidizing media, in strong acid or alkali solutions, also at high process pressures and temperatures. The flat glass membrane version with an integrated auxiliary platinum electrode (SG) is available for media containing a high amount of particles.



Figure 30 InPro 480x(i)

4.4.5 Prepressurized electrolyte pH electrodes

These electrodes have been designed for use at medium operating pressures and in particular where reliable and highly accurate measurements are of special importance.

METTLER TOLEDO's **InPro 325x(i)** series is available with an expanded selection of different pH-sensitive glass membranes. This series delivers high measurement performance under the most diverse operating conditions, both in chemical and biotech processes. The following features make the **InPro 325x** series of pH electrodes dependable measurement tools in demanding applications:

- Extended operating life and precise measurement values:
Any ingress of process medium into the reference system is avoided by (pre-)pressurization of the liquid electrolyte. Permanent overpressure within the electrode ensures that the diaphragm is continuously cleaned by the action of the constant outflow of small amounts of electrolyte through the diaphragm.
- Resistance to potential measurement problems at the diaphragm:
The silver-ion barrier integrated in the reference system prevents contamination or plugging of the diaphragm by black silver sulfide during measurements in process media containing sulfides or amino acids.



Figure 31 InPro 325x(i)

4.4.6 Dual-membrane pH electrodes

The chlor-alkali process is very tough on conventional pH electrodes. It exposes them to high temperatures, and clogging and poisoning from a variety of compounds. Chlorine diffuses through the electrode's diaphragm and attacks the reference system. This results in incorrect pH measurement and shorter sensor lifetime. METTLER TOLEDO's **InPro 4850 i** is a combination pH electrode featuring a sodium membrane glass that uses the sodium concentration in the process (brine) as a reference. The difference in electrical potential between the pH glass and the sodium reference glass is calculated into the pH value. The sodium reference system is highly resistant to chlorine and other oxidizing agents. This makes the sensor very well suited for the demanding process conditions in chlor-alkali production. Analog to digital signal conversion ensures 100% signal integrity and stability.



Figure 32 InPro 4850 i

4.4.7 pH measurements in high purity water samples

Pressurized gel-filled electrodes provide greater stability of the reference diaphragm/junction potential by forcing a small amount of potassium chloride gel through it. The METTLER TOLEDO Thornton **pHure Sensor™** system offers this type of electrode. It requires no maintenance other than occasional calibration throughout its one year life.



Figure 33 pHure Sensor

4.4.8 Installation in an upside-down position

An air-cushion system in the reference electrolyte eliminates any possible disturbance at the diaphragm caused by air bubbles in the electrolyte. METTLER TOLEDO's **InPro 3100 UD** is intended for bottom-entry installation.



Figure 34 InPro 3100 (i)

4.4.9 For food and beverage applications

InPro X1™ HLS is a digital, food-safe pH sensor that withstands clean-in-place processes. The sensor's unbreakable pH-sensing X-Chip™ technology eliminates the risk of glass contamination. InPro X1 HLS has a hygienic design, with all materials selected for food or beverage contact applications. It offers short response times, very low offset and slope degradation, a long sensor lifetime, and features an integrated temperature sensor and titanium solution ground.



Figure 35 InPro X1 HLS

4.4.10 For low maintenance and simple installation

Polymer-body electrodes such as METTLER TOLEDO's **InPro 4501/4550** are especially designed for high process pressures and temperatures, with a special resistant polymer shaft material (PVDF or PPS) and high-temperature glass quality. NPT threads allow the sensor to be screwed directly into immersion tubes, pipes, process vessels, etc.



Figure 36 InPro 4501



Figure 37 InPro 4550

4.5 Electrode maintenance

Regular maintenance is very important for prolonging the lifetime of any pH electrode. Electrodes with liquid electrolyte need the electrolyte to be topped-up when the level threatens to become lower than the level of the sample solution. This maintenance prevents a reflux of the sample into the electrode. The complete reference electrolyte should also be changed regularly, for example once a month. This ensures that the electrolyte is fresh and that no crystallization occurs despite evaporation from the open filling port during measurement.

It is important not to get any bubbles on the inside of the electrode, especially near the junction. If this happens the measurements will be unstable. To get rid of any bubbles, gently shake the electrode in a vertical motion as with a fever thermometer.

4.6 Electrode storage

Electrodes should always be stored in aqueous and ion-rich solutions. This ensures that the pH-sensitive gel layer which forms on the pH glass membrane remains hydrated and ion rich. This is necessary for the pH membrane to react in a reliable way with respect to the pH value of a sample.

4.6.1 Short term storage

In between measurements or when the electrode is not being used for brief periods of time, it is best to keep the electrode in a holder containing its inner electrolyte solution (e.g. 3 mol/L KCl), or in a pH 4 or pH 7 buffer. Ensure that the level of solution in the beaker is below that of the filling solution in the electrode.

4.6.2 Long term storage

For long term storage, keep the electrode wetting cap filled with the inner electrolyte solution, pH buffer 4 or 0.1 mol/L HCl. Make sure that the filling port for reference and combination electrodes is closed so as to avoid loss of the electrolyte solution through evaporation, which can cause the formation of crystals within the electrode and junction.

Never store the electrode dry or in distilled water as this will affect the pH-sensitive glass membrane and thus shorten the lifetime of the electrode.

Although regeneration can restore an electrode that has been incorrectly stored, following these recommendations will ensure that your electrode is always ready to use.

4.7 Electrode cleaning

To clean the electrode, rinse it with deionized water after each measurement but never wipe it clean with a tissue. The surface of the paper tissue can scratch and damage the pH-sensitive glass membrane, removing the gel-layer and creating an electrostatic charge on the electrode. This electrostatic charge causes the measured signal to become very unstable. Special cleaning procedures may be necessary after contamination with certain samples. These are described in greater detail below.

4.7.1 Blockage with silver sulfide (Ag_2S)

If the reference electrolyte contains silver ions and the sample being measured contains sulfides, the junction will become contaminated with a silver sulfide precipitate. To clear the junction of this contamination, clean it with 8 % thiourea in 0.1 mol/L HCl solution.

4.7.2 Blockage with silver chloride (AgCl)

The silver ions from the reference electrolyte can also react with samples that contain chloride ions, resulting in an AgCl precipitate. This precipitate can be removed by soaking the electrode in a concentrated ammonia solution.

4.7.3 Blockage with proteins

Junctions contaminated with proteins can often be cleaned by immersing the electrode into a pepsin/HCl (5% pepsin in 0.1 mol/L HCl) solution for several hours.

4.7.4 Other junction blockages

If the junction is blocked with other contaminations, try cleaning the electrode in an ultrasonic bath with water or a 0.1 mol/L HCl solution.

4.8 Electrode regeneration and lifetime

Even electrodes that have been well maintained and properly stored may start performing poorly after some time. In such cases it may be possible to regenerate the pH-sensitive glass membrane and restore the electrode to its previous level of performance using an ammonium bifluoride regeneration solution. This regeneration solution is based on a highly diluted solution of hydrofluoric acid which etches away a very thin layer of the glass membrane, exposing a fresh surface area.

When using the regeneration mixture do not leave the electrode in the solution for longer than 1-2 minutes or the entire pH-sensitive membrane will be corroded away and the electrode rendered useless.

The expected lifetime of a correctly used and maintained pH electrode is around one to three years. Factors that contribute to a reduction of the lifetime of an electrode include high temperatures and measuring at extreme pH values.

5 Comprehensive pH theory

In the previous sections the practical aspects of pH measurements were discussed. This chapter will principally deal with the theoretical background to pH measurements and is intended for readers wishing to acquire a more fundamental understanding of pH theory. First, the basic pH theory is developed, then we will have a look at the sensor theory and at the end some special topics will be dealt with.

5.1 Definition of the pH value

According to Sørensen the pH is defined as the negative logarithm of the H_3O^+ ion activity:

$$\text{pH} = -\log [a_{\text{H}^+}]$$

From the equation we can see that if the H_3O^+ ion activity changes tenfold, the pH value changes by one unit. This nicely illustrates how important it is to be able to measure even small changes in the pH value of a sample.

Often, the pH theory is described with H^+ ions in connection with pH values, although the correct ion to refer to is the hydronium (or as it is officially known according to IUPAC: oxonium) ion (H_3O^+):

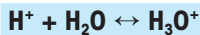

Not only acids and bases show dissociation behavior to form hydronium ions or hydroxide ions, but pure water also dissociates to form hydronium and hydroxide ions:

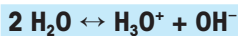

The dissociation constant for this behavior is called K_w and is also known as the autoionization or autodissociation of water:

$$K_w = \frac{[\text{H}_3\text{O}^+][\text{OH}^-]}{[\text{H}_2\text{O}]} = [\text{H}_3\text{O}^+][\text{OH}^-] = 10^{-14} \text{ (25 }^\circ\text{C)}$$

From the K_w equation we can see that when equal amounts of H_3O^+ and OH^- are present the solution is neutral, and this is the case when both $[\text{H}_3\text{O}^+]$ and $[\text{OH}^-]$ are 10^{-7} mol/L, so at pH 7. When a higher concentration of H_3O^+ ions is present, then the pH value goes into the acidic region of the pH scale, for example a H_3O^+ concentration of 10^{-3} mol/L (and thus $[\text{OH}^-] = 10^{-11}$ mol/L) gives a pH value of 3.

To be able to measure this value in a sample solution we need to know how pH sensors react to the acid concentration in the solution. We will examine this later in this chapter.

5.2 Correlation of concentration and activity

Up to now we have only discussed the concentration of acids and bases as the determining factor for the pH value measurement. In reality though what is actually measured by a pH sensor is the activity of the hydronium ions in solution. The concentration is only used, as in many other chemical processes, as a simplification for using the activity of a solution. In many conditions the use of the concentration is a very good approximation to using the activity.

The activity of the hydrogen ion (a_{H^+}) is defined by the concentration of hydrogen ions and the activity coefficient (γ_{H^+}). The concentration in this case is usually given as the molality ($b = \text{mol/kg solvent}$) and not the molarity ($c = \text{mol/L solution}$), as molality is a less ambiguous definition. The activity is then given by:

$$a_{\text{H}^+} = \gamma_{\text{H}^+} \times b_{\text{H}^+}$$

In dilute solutions the approximation $a_{\text{H}^+} = b_{\text{H}^+}$ can be made.

The activity coefficient is not a universal constant; the value of this number again depends on various factors such as temperature (T), total ion strength (I), the dielectric constant, ion charge (z), the size of the ions (in Angstroms) and also on the density (d) of the medium.

There are two main effects which can be observed when noting the difference between ion activity and ion concentration. These are the so-called salt effect and medium effect.

The influence of salts present in a solution of which the pH value is measured is called the salt effect. This salt effect is denoted by the symbol $\gamma_{\text{H}^+}^x$

and is defined as:

$$\log \gamma_{\text{H}^+}^x = \frac{-0.5 I^{1/2}}{1 + 3 I^{1/2}}$$

In this equation "I" is the symbol for the total ionic strength = $\frac{1}{2} \sum c_i z_i^2$

If we assume in the case of pH measurement that both the anion and the hydrogen ion are monovalent, z_i will be equal to 1 and the total ion strength I is determined by the molality. The influence of the salt effect on the activity coefficient of selected ion concentrations is shown in the following table.

Molality	0.001	0.005	0.01	0.05	0.1
Activity coefficient	0.967294	0.935044	0.915247	0.857205	0.829586

When we now compare a pH measurement in a solution of 0.01 mol/L HCl with or without salt present, we get the following comparison:

0.01 mol/L HCl solution	0.01 mol/L HCl solution with 0.09 mol/L KCl
$\begin{aligned} \text{pH} &= -\log (b_{\text{H}^+} \times \gamma_{\text{H}^+}^x) \\ &= -\log (0.01 \times 0.915) \\ &= -\log (9.15 \times 10^{-3}) \\ &= 2.04 \end{aligned}$	$\begin{aligned} \text{pH} &= -\log (b_{\text{H}^+} \times \gamma_{\text{H}^+}^x) \\ &= -\log (0.01 \times 0.829) \\ &= -\log (0.829 \times 10^{-3}) \\ &= 2.08 \end{aligned}$

From this example it can be seen that the pH value increases by 0.04 pH units (the H^+ activity decreases) in solutions with a higher ion strength. This explains why solutions with the same acid content may show different pH values if there are other salt ions present in the solution.

The second effect which links activity to concentration is the so-called medium effect. The medium effect is designated with:

$$\gamma_{\text{H}^+}^m$$

This effect shows what influence the medium (solvent, etc.) will have on the H^+ ion activity. With this effect electrostatic and chemical interactions play an important role. For example, the H^+ activity is 200 times greater in ethanol than in water.

When taking both the salt effect and medium effect into account, the relationship between concentration and activity then becomes:

$$a_{\text{H}^+} = \gamma_{\text{H}^+}^x \times \gamma_{\text{H}^+}^m \times b_{\text{H}^+}$$

From these examples we can see that it is very important to have detailed knowledge of the measured sample, since the more accurately defined the measuring conditions are, the more reproducible the pH values obtained will be.

5.3 Buffer solutions

Buffer solutions are a very important part of an accurate pH measurement. Standard buffers are used to calibrate pH sensors and to check their performance. The most important property of a pH buffer is its buffering capacity, hence its name. This property enables a pH buffer to remain at a constant pH value, even if external substances are introduced into the buffer solution.

The buffering capacity of a buffer solution depends on the fact that weak acids only partly dissociate, causing the following equilibrium reaction:



In this equilibrium, the anion A^- can act as a base, since it can withdraw protons from the system. The non-dissociated acid HA, however, can supply the system with protons.

A buffer solution in its equilibrium state therefore has enough anions (A^-) to take up any protons added to the system, but also has enough non-dissociated acid available to replace any protons withdrawn from the system. Since the non-dissociated acid HA can act as an H^+ donor and the dissociated acid A^- as an H^+ acceptor, a buffer solution will be at its most powerful when both HA and A^- are present in equal concentrations.

If we first have a closer look at the theory of buffer solutions, we can then find out how suitable a certain solution is as a buffer. This depends on several properties of the buffer solution, such as buffer capacity, temperature influences, and changes of the pH value due to dilution of the buffer solution. These properties are documented for many standard buffer solutions and can be found in the literature.

From the formula above we can write the equilibrium constant for a dissociated acid as follows:

$$K_a = \frac{[H^+][A^-]}{[HA]}$$

This can be then be re-written as:

$$\frac{1}{[H^+]} = \frac{1}{K_a} \times \frac{[A^-]}{[HA]}$$

and then taking the logarithm on both sides:

$$\log \frac{1}{[H^+]} = \log \frac{1}{K_a} + \log \frac{[A^-]}{[HA]}$$

Since

$$\log \frac{1}{[H^+]} = -\log [H^+] = \text{pH}$$

and

$$\log \frac{1}{K_a} = -\log K_a = \text{p}K_a$$

we then get:

$$\text{pH} = \text{p}K_a + \log \frac{[A^-]}{[HA]}$$

This equation is known as the HENDERSON-HASSELBALCH equation.

From this last equation we can see that if a buffer solution is at its strongest and therefore $[A^-] = [HA]$, that the pH value corresponds to the negative log of the dissociation constant,

$$\text{pH} = \text{p}K_a$$

This equation is very helpful when making a buffer solution of a weak acid with known pKa value.

5.3.1 Buffer capacity (B)

The buffer capacity is defined as the ability of a buffer solution to maintain its pH value even after the addition of a strong acid or base.

As we have seen in the previous section, the greatest buffer capacity is when $\text{pH} = \text{pK}_a$, but the overall buffer capacity of a weak acid or base is limited to $\text{pH} = \text{pK}_a \pm 1$.

As an example of the buffer capacity of a weak acid we will look at a titration curve of acetic acid (CH_3COOH) with OH^- ions titrated into the solution (Figure 38). Acetic acid has a pK_a value of 4.8, so this solution starts with a low pH value and the pH value increases when more hydroxide ions are titrated into the solution. At the beginning the change is quite big with every drop of hydroxide solution, but when the concentrations of the non-dissociated acid and dissociated acid start becoming equal the curve becomes flatter. As $[\text{A}^-] = [\text{HA}]$ when $\text{pH} = \text{pK}_a$, we expect the curve to become flat around pH 4.8, since this is the pH value where the buffering capacity should be most pronounced.

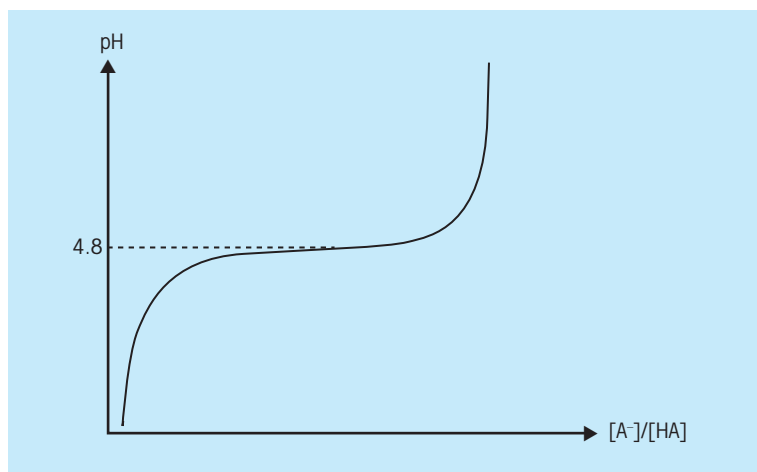

Figure 38 Buffering capacity of acetic acid.

When making and using buffer solutions you have to be aware of external influences on the acid/base equilibrium as well. One example of this could be the uptake of CO_2 from the air.

5.3.2 Dilution value (ΔpH)

The dilution value of a buffer solution indicates how much the pH value changes when the buffer solution is diluted with an equal amount of distilled water.

A positive dilution value means that the pH will increase whereas a negative dilution value means that the pH will decrease with increasing solution.

5.3.3 Temperature effect ($\Delta\text{pH}/\Delta\text{T}$)

We have seen the pH value is derived from the activity of the H^+ ions in the solution. Since the ion activity is temperature dependent, the temperature will also influence the pH value.

The temperature coefficient expresses changes of the pH value per $^{\circ}\text{C}$.

5.4 The measurement chain in the pH measurement setup

We saw in chapter “1.3 The tools for pH measurements” on page 12, that a pH measurement is actually the measurement of a potential. The changing potential of a pH-sensitive electrode is measured against the stable potential of a reference electrode. A measurement setup is shown in Figure 7 on page 13.

The principle of the setup is that metal conductors within the two electrodes are connected to each other through one or more electrolytes to form a galvanic chain. To this galvanic chain (pH and reference electrode) a meter with a high input resistance is attached and this connects the two electrodes internally and measures the chain potential E .

This galvanic potential E is defined by the Nernst equation:

$$E = E_0 + 2.3 \frac{RT}{nF} \times \log a_{\text{H}^+}$$

which we have seen before in Figure 6 on page 12.

In order to be able to compare the galvanic potentials of different electrodes with different reference systems, the standard hydrogen electrode (SHE) or normal hydrogen electrode (NHE) was introduced as a universal reference electrode. The potential of the SHE is by definition zero at all temperatures. The SHE consists of a platinized platinum sheet which is immersed in a solution of $a_{H^+} = 1.0$ and surrounded by hydrogen gas at 1 bar.

In the Nernst equation E_0 is the standard potential at $a_{H^+} = 1$. The factor $2.3 RT/nF$ (E_N) is the slope of the pH electrode and gives the change in measured potential with tenfold change in H^+ activity, or per pH unit. The value of E_N depends on the temperature T in Kelvin, and is often referred to as the slope factor. Some examples for the slope at certain temperatures are given in Figure 39 below.

Temperature	E_N Value (mV)/pH
0 °C	$E_N = 54.2$ mV/pH
25 °C	$E_N = 59.2$ mV/pH
50 °C	$E_N = 64.1$ mV/pH

Figure 39 Temperature dependence for the pH electrode slope factor.

When we look at the measurable chain potential E from the Nernst equation in a bit more detail, we find that this chain potential consists of several intermediate potential points, which are shown in Figure 40 below.

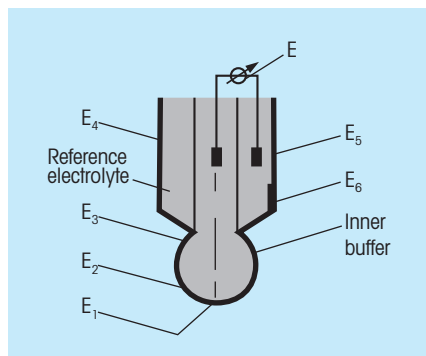

Figure 40 Different sources of potential in a combination electrode.

5.4.1 pH electrode

The chain potential starts at the contact area between the sample solution and the pH electrode glass membrane, where the potential E1 is measured in correlation with the pH value of the sample solution. In order to measure E1 and assign a definite pH value to it, all other single potentials in the chain E2-E6 have to be constant. The only variable signal is caused by the potential difference between inner electrolyte and sample solution over the pH membrane. The last point in the chain is E6, the potential between the reference electrode electrolyte and the sample solution again, which has a constant potential since the reference electrode is insensitive to the pH value of the sample.

The other potentials E2, E3, E4, and E5 are the consecutive steps in the chain from the sample through the pH electrode to the meter, and back again from the meter through the reference electrode to the sample solution. All these separate steps can be seen in Figure 40 on page 79.

The potential E1 is transferred to the inside of the pH membrane glass via the gel layer on the glass membrane and the pH glass membrane (as shown in "Figure 8 Cross sections through the glass membrane." on page 14), where another gel layer is present as an interface between the inside of the pH electrode and the inner buffer solution. The potential difference between the outside of the pH glass membrane and the inside of the pH glass membrane is the potential E2 in Figure 40 on page 79.

Physically this works by transferring the potential via an equilibrium of the hydrogen ions which arises at the interface between the measuring solution and the outer pH membrane gel layer. If the activity of the hydrogen ions is different in the two phases, hydrogen ion transport will occur. This leads to a charge at the phase layer, which prevents any further H⁺ transport. This resulting potential is responsible for the different hydrogen ion activities in the sample solution and the gel layer. The number of hydrogen ions present in the gel layer is given by the silicic acid skeleton of the glass membrane and can be considered a constant and therefore independent of the measuring solution.

The potential in the outer gel layer of the pH-sensitive membrane is then transferred by the Li^+ ions found in the glass membrane to the inside of the glass membrane, where another phase boundary potential arises (E3 in Figure 40 on page 79).

The potential E3 is then transferred to the lead-off wire in the pH electrode (E4) via the inner buffer solution of the pH electrode and from there to the meter.

5.4.2 Reference electrode

When the pH electrode potential chain (E1-E4) signal goes to the meter, there needs to be a reference signal available in the meter as well to measure the pH signal against. This is done with the reference part of the electrode, where another potential chain (E5-E6) ensures this stable potential independent of the sample solution.

From the meter there is a connection to the reference element of the reference electrode and from there an interface between the reference element and the reference electrolyte solution (potential E5).

Of the different reference elements, the silver/silver-chloride element has become the most important one. Compared to the calomel electrode the silver/silver-chloride reference has some important advantages, but it is mainly because of environmental reasons that the calomel reference electrode has almost completely disappeared.

The next step is the potential E6, which is the connection between the reference electrolyte on the inside of the reference electrode and the sample solution on the outside of the electrode. Again, it is important that the potential is stable here as it is used as a reference signal. The junction is naturally very important for this particular contact since it allows the diffusion of the ions through the junction.

The critical property of the junction is the diffusion of ions through it which generates the diffusion potential ($E6/E_{\text{diff}}$). The diffusion potential depends not only on the type of junction and its properties, but also on the diffusing ions.

Since E_{diff} is a part of the potential in every measuring chain, the pH values of different measuring solutions can, strictly speaking, only be compared if the diffusion potential is identical in all solutions. In practice this is not always possible, so it is important to keep E_{diff} small and constant to limit the measurement error.

The migration velocity of ions is determined by their charge and size. The size of an ion is determined not by its "net" size, but by the size of its hydration cover. All ions in aqueous solutions are surrounded by polar water molecules. This means that a small but highly hydrated lithium ion for example migrates slower than a much larger but only slightly hydrated potassium ion. Since the H^+ and the OH^- ions migrate in accordance with completely different mechanisms, they have a much higher ion mobility compared to all other ions. Examples of migration speeds for different ions are shown in Figure 41 below.

Ionic mobilities (in $10^{-4} \text{ cm}^2/\text{s} \cdot \text{V}$) at 25°C			
H^+	36.25	OH^-	20.64
Li^+	4.01	F^-	5.74
Na^+	5.19	Cl^-	7.91
K^+	7.62	NO_3^{-2}	7.41
NH_4^+	7.62	CH_3COO^-	4.24

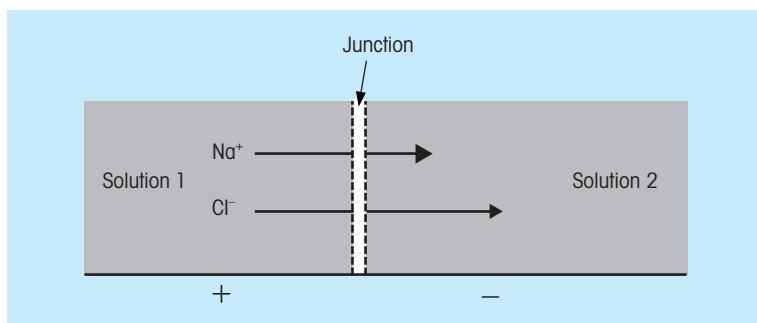

Figure 41 Ion mobility and diffusion of ions through a junction.

Using the example of sodium and chloride ions we see from the table and figure above that the sodium and chloride ions diffuse through a junction from solution 1 into solution 2 at different speeds. Since Cl^- ions in the solution migrate much faster than Na^+ ions, a charge separation occurs.

This charge separation then causes a diffusion potential which counteracts the initial migration. This in turn leads to a dynamic equilibrium which takes a long time to stabilize. This means that the different diffusion speeds of the ions in the reference electrolyte through the junction cause a slower response time of the electrode. So it is very important that the junction is highly porous allowing a strong electrolyte flow in order that the response time is kept as short as possible.

The charge separation and therefore the diffusion potential E_{diff} increases when the mobility of the cations and anions is very different. This effect is particularly noticeable in strongly acidic and basic solutions, the typical solutions often used in pH measurements.

Another factor which determines E_{diff} is if one of the two solutions is very dilute. A typical example of such a pH measurement is an ion-deficient sample such as pure water. In this case, the diffusion potential also increases since the charge difference is amplified by the ion-deficient sample outside the junction.

To keep the diffusion potential as small as possible you should ensure that the reference electrolyte is a concentrated and equitransferent solution (equal mobility of anions and cations). This is the case with the most commonly used KCl and KNO_3 reference electrolytes, as can be seen in Figure 41 on page 82.

However, despite taking such precautions, the diffusion potential at extreme pH values is considerable even with ideal reference electrolytes. This is demonstrated in the example below (at 25 °C):

Inner electrolyte	Sample solution	Diffusion potential	Δ pH
KCl (sat.)	HCl (1 mol/L)	$E_{\text{diff}} = + 14.1 \text{ mV}$	0.238 pH units
KCl (sat.)	NaOH (1 mol/L)	$E_{\text{diff}} = - 8.6 \text{ mV}$	0.145 pH units

This description of the diffusion potential makes it clear that some pH measurements will therefore be more difficult than others. Care should be taken with very dilute solutions, or solutions which are ion-poor, such as non-aqueous solutions. In such cases the diffusion potential will become quite high resulting in an unstable reference signal. Contaminated junctions also have this effect as the blockage of the junction inhibits the free flow of electrolyte.

5.5 Calibration / adjustment of the pH measurement setup

There are two settings in the meter which are adapted to the specific electrode attached to the meter and are affected when the pH electrode and the meter setup is adjusted, namely the zero point offset (mV) and the slope (mV/pH) of the electrode. Since there are two settings that have to be adjusted it follows that a two-point calibration is the minimal adjustment that should be performed.

An adjustment of the zero point and the slope has to be performed to compensate for any deviations from the theoretical values. These deviations occur due to non-ideal behavior of the electrode. A buffer solution with a pH value of 7.00 corresponds to the zero point of most glass pH electrodes and is especially intended for the zero point calibration. In most cases, depending on the expected measurement range, buffer solutions of pH 4.01 or pH 9.21 (or 10.00) are recommended to adjust the slope.

In the figure below, both these adjustments are illustrated. The drawing on the left depicts the offset adjustment so that the mV deviation from the theoretical 0 mV at pH 7.00 is shown. The slope adjustment is illustrated on the right. Here the deviation from the theoretical 59.16 mV/pH at 25 °C is depicted.

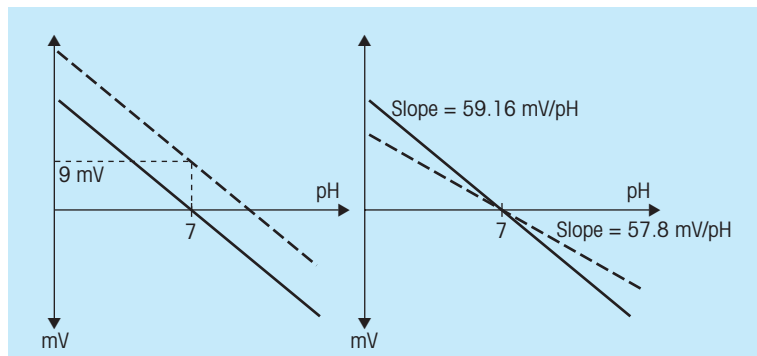

Figure 42 Left: offset adjustment of a pH electrode in the pH meter, right: slope adjustment of a pH electrode. Solid lines show ideal behavior, dashed lines show real behavior.

5.6 The influence of temperature on pH measurements

Temperature has an influence on both the electrode and the sample. We will take a closer look at this influence in the sections below.

5.6.1 Temperature dependence of the electrode

Temperature influences a pH electrode in several different ways:

Slope

Looking at the Nernst equation, which gives the relationship between measured mV values and pH value of the sample for a pH electrode, we see that the slope contains the temperature in Kelvin:

$$E = E_0 + 2.3 \frac{RT}{nF} \times \log a_{H^+}$$

When we fill in all the numbers, except the temperature in Kelvin (T), we get:

$$E = E_0 - 0.198 \times T \times \text{pH}$$

From this equation we can now clearly see that the slope of an electrode is linearly dependent on the temperature. Because this dependence is linear the behavior is fully predictable and can be compensated for by a pH meter and electrode with integrated temperature sensor.

5.6.2 Isothermal intersection

The isothermal intersection depends on the behavior of the individual potentials E1 to E6 and is a characteristic of every electrode. For an ideal electrode the calibration lines of different temperatures would intersect at the zero point of the electrode (pH 7.00/0 mV) and the slope would always be proportional to the absolute temperature.

Since the overall potential of the pH electrode is composed of the sum over E1-E6, which all have their respective temperature dependencies, the isothermal intersection may not always coincide with the zero point of the electrode.

It is important for an electrode to have the isothermal intersection and the zero point as close together as possible, since the nearer these are to pH 7 the smaller the error in the temperature compensation will be. The measuring error increases with an increasing temperature difference between the calibration and sample solutions, these errors can be in the order of 0.1 pH units. The most accurate pH value is obtained when the temperature of the calibration and sample solutions is identical. These measurement errors are illustrated in Figure 43 below.

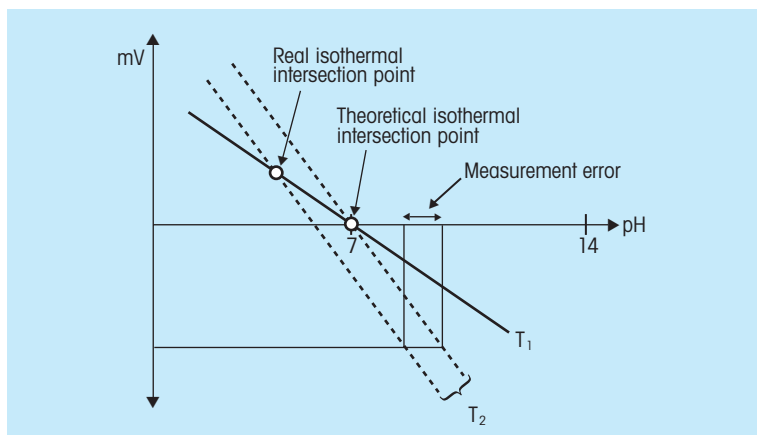

Figure 43 Isothermal intersection, theory and practice.

If the real isothermal intersection does not coincide with the theoretical one the measurement error can be quite large, depending on the temperature difference between samples or between sample and calibration. Furthermore, the error can become significant if the real isothermal intersection is very far from the theoretical intersection, and measurement and calibration differ in temperature.

5.6.3 Further temperature phenomena

The response time of the electrode can also be affected if the temperature changes between or during measurements.

If the change in the temperature of the medium is rapid, a conventional pH electrode will drift until the temperature of the electrode and the medium becomes equal. In order for a combination electrode to react rapidly to the temperature changes in the sample, the temperature of the inner pH electrode and the outer reference electrode must always be identical. This is only possible with a symmetrical arrangement of the pH and reference elements.

5.6.4 Temperature dependence of the measured sample

Every sample solution has a characteristic temperature and pH behavior which can be expressed with the so-called temperature coefficient. This describes how the pH value changes when the temperature changes. Since this pH change is different for every sample, it is almost impossible to compensate for it.

The first point to note is that the dissociation constant of water itself is temperature dependent. In pure water when the temperature increases from 0 and 100 °C, the neutral point shifts 1.34 pH units downwards as a result of the temperature dependent ion product. In other words the K_w of water decreases with increasing temperature. A similar behavior is seen in weak acids and bases, since their dissociation constants are also temperature dependent.

The temperature coefficient is determined by two parameters:

- activity coefficient (γ)
- acid constant

The temperature dependence of the activity constant γ becomes larger when γ is further away from 1, when there is a large deviation between the concentration and the activity of a solution. This is especially the case for concentrated solutions and in the presence of ions with a high electrical charge.

The acid constant pK_s is also temperature dependent, but this relationship is non-linear, which means that the dissociation behavior of an acid changes with temperature. This dissociation behavior causes a change in the H^+ concentration with a change in temperature and thus a real pH value change.

In general, organic acid/base systems show a higher temperature coefficient than inorganic systems, and alkaline solutions are more temperature dependent than acidic solutions.

This is illustrated by the following examples:

pH value at:	20 °C	30 °C
0.001 mol/L HCl	3.00	3.00
0.001 mol/L NaOH	11.17	10.83
Phosphate buffer	7.43	7.40
Tris buffer	7.84	7.56

These examples clearly show that large temperature coefficients can even occur in nearly neutral solutions and therefore that temperature has to be taken into account when comparing pH measurements obtained at different temperatures. Ideally, samples should be measured at the same temperature to be able to make comparisons between them.

In general it is not possible to do temperature compensation for real changes in pH for chemical solutions. However, temperature compensation tables have been determined for standard buffer solutions.

5.7 Phenomena in the case of special measuring solutions

Different problems may occur when measuring in samples that do not consist of easy to measure clear, aqueous solutions. These problems can be of electrical or chemical origin and are briefly discussed in this section.

5.7.1 Alkaline error

The alkaline effect is the phenomenon where H^+ ions in the gel layer of the pH-sensitive membrane are partly or completely replaced by alkali ions. This leads to a pH measurement which is too low in comparison with the number of H^+ ions in the sample. Under extreme conditions where the H^+ ion activity can be neglected the glass membrane only responds to sodium ions.

Even though the effect is called the alkaline error, it is actually only sodium or lithium ions which cause considerable disturbances. The effect increases with increasing temperature and pH value ($\text{pH} > 9$), and can be minimized by using a special pH membrane glass. An example of electrode behavior under these conditions is given in Figure 44 below.

5.7.2 Acid error

In strongly acidic media, acid molecules are absorbed by the gel layer leading to a decrease in the H^+ ion activity in the gel layer. Consequently, an artificially high pH value is registered. The acid error is less disturbing than the alkaline error and is only relevant at very low pH values. An illustration of this is also given in Figure 44 below.

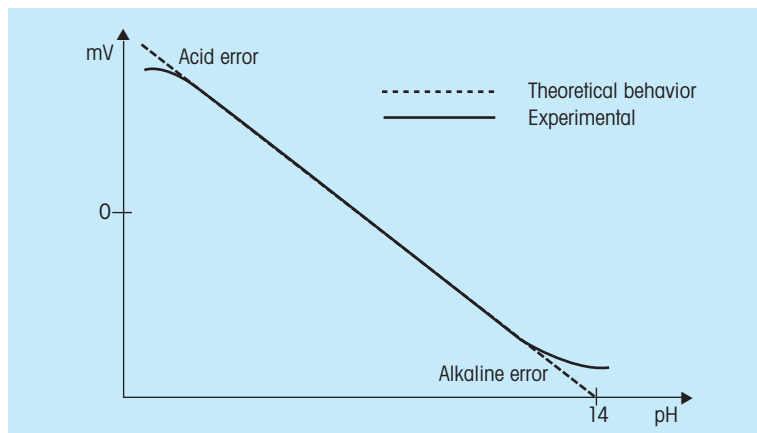
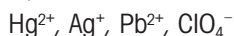

Figure 44 Illustration of alkaline and acid error electrode behavior.

5.7.3 Reactions with the reference electrolyte

Another problem source can be the occurrence of chemical reactions between electrolytes and the measured solution. The resulting precipitates block the pores of the junction and thus increase the electrical resistance considerably.

When using KCl as a reference electrolyte the following ions can precipitate and form compounds of low solubility:



Silver chloride may further react with bromide, iodide, cyanide, and especially with sulfides and sulfide compounds such as cystine and cysteine. Contamination due to silver sulfide results in a black coloration of the junction. Contamination of the junction may result in unsatisfactory measurements because of:

- an increase in the response time of the electrode, or
- a diffusion potential (E_{diff}), which enters into the pH measurement as a direct error

In order to prevent such reactions between the electrolyte and the sample solution, you can either use an electrolyte which does not react with the above ions, or you can use an electrode with a double junction and a bridge electrolyte which does not react with the sample.

5.7.4 Organic media

The measurement of pH in organic media or non-aqueous solutions (less than 5 % water) presents a special challenge, since the classical definition of pH does not apply for such samples.

When determining the pH value in non-aqueous samples it is important to note that the conventional pH range of pH 0 to pH 14 is based on the dissociation behavior of water and is therefore not valid. In this case, the dissociation equilibrium, the ion product of the solvent used and not the ion product of water is relevant. This can result in completely different concentration ranges for H^+ ions in the solvent and thus a completely different pH scale. Figure 45 on page 92 illustrates this by showing the actual valid pH ranges for some common solvents.

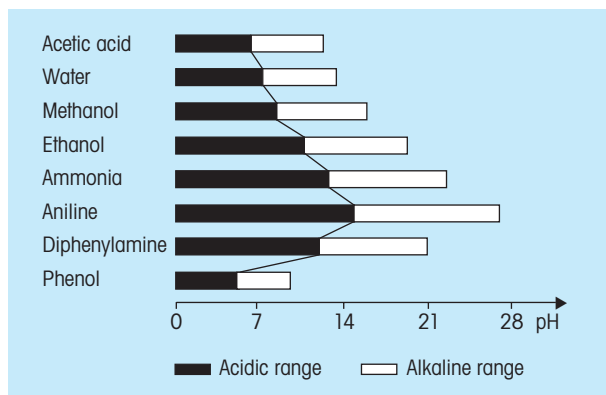

Figure 45 pH scale for different solvents.

In applications involving non-aqueous solvents it is common to measure relative rather than absolute pH, e.g. titrations in oil. In this case it is the potential jump observed when the reaction goes to completion and not the pH scale that is important. When doing a pH measurement in a non-aqueous sample it is important to remember that the measurement will not give an absolute pH value. Furthermore, the electrode will lose its hydrated gel layer around the pH-sensitive membrane. To ensure that measurements can still be performed you must rehydrate the gel layer in an ion-rich aqueous solution between experiments.

If you want to measure quantitatively in non-aqueous solvents you can prepare a calibration curve for the pH glass electrode with different samples that have a known composition corresponding to the conditions of the samples to be measured. This makes it possible to differentiate the different sample compositions during the measurement, without having to quantify an absolute value during the measurement.

Remember that non-aqueous solvents are usually very ion-deficient and that this can result in measurement instabilities.

5.8 Signal processing

Parameters are measured in a process with the aim of controlling and influencing the process.

Both the product and the process are important:

Product	– Optimal quality
Process	– Max. yield – Min. expenditure – High degree of safety – Environmental concern

The sensor delivers a signal, which is upgraded and interpreted accordingly. By comparison with the nominal value, measures are taken which influence the process.

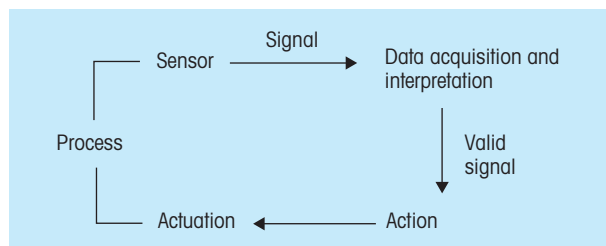

Figure 46 Typical process control loop.

For pH measurement this means that:

- The high-resistance sensor signal is transformed into an interference-free low-resistance signal; preferably with galvanic isolation in order to prevent ground loops.
- This signal is scaled to pH by calibration, for example by the buffer values of pH 4 and pH 7.
- Further actions might be taken in order to obtain a valid signal, for example capturing (recording) the quality parameters of the sensor.

- Transmission of the scaled pH value in a standardized signal, normally 4 to 20 mA. The current output is insensitive to lead wire resistance and very interference-proof compared to the signal of the electrode. By the minimal output value of 4 mA (live zero) cable breaks can be detected.

These tasks are managed by the transmitter. The process can either be influenced manually (switch function) or automatically via the process control system.

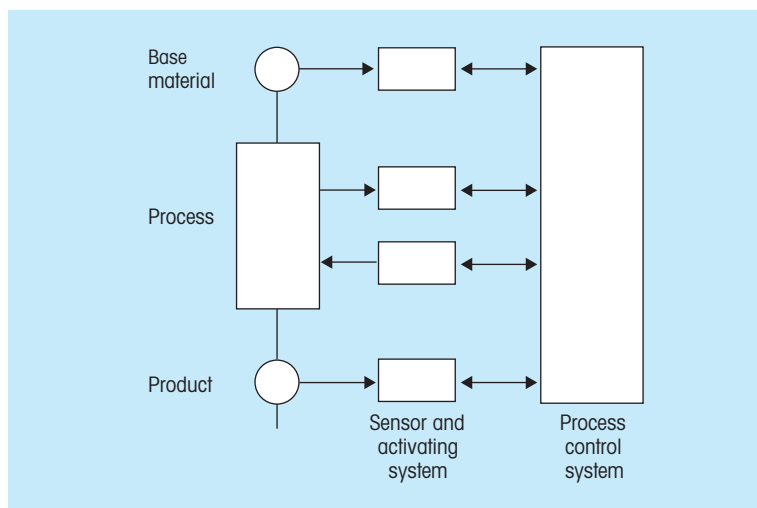

Figure 47 Intersection of the process control system and sensor/activator system.

pH transmitters are often microprocessor controlled devices, which facilitates the operation (e.g. through different calibration methods as 1-point and 2-point calibrations with buffers, 1-point calibration with process samples, and calibration through setting the parameters of the electrode which has been tested in the lab). These devices are additionally very flexible in action, since adaptations to the process can be done through the software.

pH electrodes have a limited life expectancy and may become useless for measurements due to contamination. Hence a lot of effort is made to insure that the pH measurements are reliable and continuous during the entire process.

For example:

- Redundancy
 - 2 or 3 measuring points at the same measuring site.
 - Alarm when $\Delta \text{pH} > \text{control value}$
 - with 3 electrodes: 2 out of 3 conditions: errors not synchronous
- Controlling the electrode with respect to breaks, decay and dynamic behavior.
- Automatic maintenance and calibration system

In order to exchange failing electrode(s) without interrupting the process, retractable housings have to be used.

Devices for industrial operations are distinguished by their sturdy constructions and high resistance to external influences.

External effects:

- Humidity and dust → IP65 or better
- Ambient temperature → -10 to $+50$ °C or better
- Electromagnetic influences are not allowed to affect the functioning (IEC standards).

The electrode input at the transmitter is characterized by an input offset resistance, an input current and by the temperature drift behavior.

Under all circumstances the input of the amplifier should be designed in such a way that the error is not larger than 0.005 pH units. For that purpose the values of the temperature drift and offset current have to be limited.

Modern amplifiers have the following data:

$$dE/dT < 25 \times 10^{-6} \text{ V/}^\circ\text{C}$$

$$R_{in} > 10^{12} \text{ Ohm}$$

$$I_b < 10^{-12} \text{ A}$$

The following example illustrates their influences:

$$\text{Input resistance } R_{IN} = 10^{12} \text{ Ohm}$$

$$\text{Input current } I_b = 0.5 \times 10^{-12} \text{ A (25 }^\circ\text{C);}$$

$$I_b 2.8 \times 10^{-12} \text{ A (50 }^\circ\text{C)}$$

$$\text{Temperature drift } dE/dT = 20 \times 10^{-6} \text{ V/}^\circ\text{C}$$

$$\text{Membrane resistance } R_M = 500 \times 10^6 \text{ Ohm}$$

Influence of the input resistance:

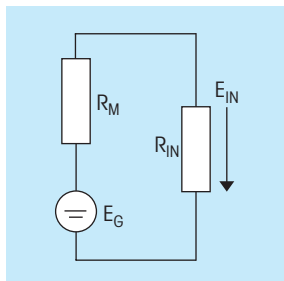

$$E_{IN} = \frac{R_{IN}}{R_M + R_{IN}} \cdot E_G$$

$$\text{error} \sim \frac{R_M}{R_{IN}} (\text{pH}_I - \text{pH}_a) \quad \text{for } R_{IN} > R_M$$

(error in pH units)

R_M : Resistance of the glass electrode

E_G : Potential of the glass electrode

For $\text{pH}_a = 4$ (measuring solution):

error 0.002 pH units

Measuring errors which depend on a limited (reduced) input resistance can be neglected as long as R_{in} is greater than 10^{12} Ohm.

Influence of the input current, if the temperature changes from 25 °C to 50 °C after calibration:

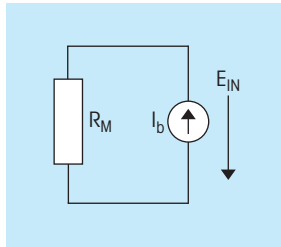

$$E_{IN} = R_M \times I_b$$

$$\begin{aligned} \text{error} &= 1.15 \text{ mV} \\ &= 0.018 \text{ pH} \end{aligned}$$

Influence of the temperature:

$$\Delta E = \frac{dE}{dT} \times \Delta T \quad \Delta T = 25 \text{ °C}$$

$$\Delta E = 500 \times 10^{-6} \text{ V} = 0.008 \text{ pH}$$

Adding all errors: total error = 0.033 pH units

At constant ambient conditions (temperature) the error can be neglected as the change of the temperature is the main disturbing source.

6 Mathematical parameters

a	= Activity of an ion
b	= Molality (mol/kg solvent)
β	= Buffer capacity of a solution
c	= Ion concentration
γ	= Activity coefficient
F	= Faraday constant (96485 A s mol ⁻¹)
I	= Ion product
pH _o	= pH value of measured solution
pH _i	= pH value of inner buffer
R	= Universal gas constant (8.3143 Nm K ⁻¹ mol ⁻¹)
S	= Slope (mV per pH unit)
T	= Temperature (absolute) (K)
E _{diff}	= Diffusion potential
E _{el}	= Electrode potential
E _o	= Zero point potential
EN	= Nernst potential
v	= Velocity of the ion
z	= Charge of the ion

InTrac, ISM, ISM Core, InPro, InPro X1, X-Chip, Equithal, and Xerolyt are trademarks of the METTLER TOLEDO Group.

www.mt.com/pro

For more information

METTLER TOLEDO Group

Process Analytics

Local contact: www.mt.com/contacts

Subject to technical changes.

© 09/2023 METTLER TOLEDO. All rights reserved.

PA0010en

Printed in Switzerland. 30 078 149