



DS100 SERIES THERMOSTATIC STEAM TRAPS

Pressures To 150 PSIG (10.3 barg)
Temperatures to 366°F (186°C)



Stainless Steel Body—Body materials of all models are Type 316L Stainless Steel.

Self Centering Valve—Leak tight shut off. Assembly of actuator and valve to impingement plate allows valve to self-align with center of valve seat orifice. Provides long lasting valve and seat.

Temperature Sensitive Actuator—316L Stainless welded actuator for maximum corrosion, thermal and hydraulic shock resistance. One moving part.

Thermal and Hydraulic Shock Resistant—Impingement plate plus welded construction prevents damage to actuator.

Long Life Valve and Seat—Stainless steel valve and seat matched together for water tight seal.

Maintenance—All models are sealed and maintenance free.

Directional Discharge—Erosion prevented by directing discharge into the center of pipe or tubing.

Best Air Handling Capacity—Fast start up and operation.

Fast Response—Quickly adjusts to condensate load or temperature changes.

One Size Suits Most Services—Universal ferruled end connection fits both 1/2" and 3/4" piping.

Two Year Guarantee—Trap guaranteed for two years against defects in material or workmanship.

Models

- **DS100**—Ferrule clamp end 1 1/8" OAL
- **DS100TE**—Tube end
- **DS110**—Ferrule clamp end 2 5/8" OAL

Applications

- CIP/SIP System Condensate Drainage
- Sterilization of Process Vessels
- Culinary Steam
- Humidifiers
- WFI System Sterilization
- Main Drips

Canadian Registration # 0E0591.9

Operating Principle

Thermal actuator is filled at its free length with a liquid having a lower boiling point than water. On start-up, valve is normally open to discharge air, non-condensibles and condensate. When steam enters trap, thermal actuator fill vaporizes to a pressure higher than line pressure. This forces valve into seat orifice

to prevent any further flow. As condensate collects, it takes heat from thermal actuator, lowering internal pressure. Line pressure will then compress thermal actuator to open valve and discharge condensate. Valve opening automatically adjusts to load conditions from minimum on very light loads to full lift at maximum load.

DS100 SERIES THERMOSTATIC STEAM TRAPS

Specification

Steam trap shall be thermostatically actuated and maintenance free. Actuator shall be of single piece, fail open design consisting of 1.2" diameter, welded 316L stainless plates. Trap shall be constructed entirely of 316L stainless steel components with wetted body surfaces finished to 20 μ inch Ra or better. Trap shall be self draining when installed vertically in piping systems. Trap shall have tube or universal ferruled connections. Ferruled connections shall be Tri-clamp compatible and designed to fit both 1/2" and 3/4" service. Trap shall be guaranteed against defects for 2 years.

Maximum Operating Conditions

PMO: Max. Operating Pressure 150 psig (10.3 barg)
 TMO: Max. Operating Temperature 366°F (170°C)
 PMA: Max. Allowable Pressure 300 psig* (20.7 barg)
 TMA: Max. Allowable Temperature 500°F* (260°C)

*May be limited by rating of utilized end connection.

Body Surface Finish:

<20 μ in. Ra internal
 Machine Polished external

Service Notes

Trap is designed to be self draining for vertical installation (discharge down).

1/2" - 3/4" ferrule service trap should be installed with 3/4" inlet gasket.

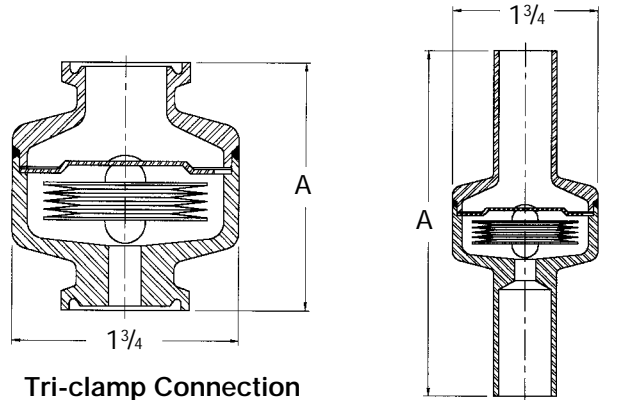

Tri-clamp Connection

Tube Connection

Connections: 1/2" - 1" Tube
 1/2/3/4" Tri-clamp

Dimensions			
Trap	End Connections	Size	inches (mm) A
DS100	Tube	1/2", 3/4", & 1"	4 1/8 (104.8)
DS100	Ferrule	1/2" & 3/4"	1 7/8 (47.6)
DS110	Ferrule	1/2" & 3/4"	2 5/8 (66.7)

Materials of Construction

Part Name	Material
Body - Inlet	316L
Actuator	316L
Body - Outlet	316L
Valve	316L

Maximum Capacity—lbs/hr 10°F Below Saturation (Kg/hr 5°C Below Saturation)														
Trap	Orifice Inches	Differential PSIG (bar)												
		5 (0.34)	10 (0.7)	20 (1.4)	30 (2.1)	40 (2.8)	50 (3.4)	60 (4.2)	70 (4.9)	80 (5.6)	90 (6.2)	100 (6.9)	125 (8.62)	150 (10.3)
DS 100	1/4	550 (249)	825 (374)	1210 (549)	1495 (678)	1750 (794)	1975 (896)	2175 (987)	2350 (1066)	2525 (1145)	2650 (1202)	2825 (1281)	3140 (1424)	3425 (1554)



3265 Sunset Lane, Hatboro, PA 19040
www.sentinelprocess.com
 P: 800.345.FLOW F: 888.329.9669