

Process Analytics Catalog

INGOLD

Leading Process Analytics

THORNTON

Leading Pure Water Analytics

U.S.
2022/23



pH/ORP
DO & Ozone
CO₂
TOC/Microbial Detection
Conductivity/Resistivity
Turbidity
Housings & Cleaning Systems
Sodium/Silica Analyzers
Chloride/Sulfate Analyzer
Gas Analyzers



Process Analytics Measurement Solutions for Industrial Applications

METTLER TOLEDO

METTLER TOLEDO's Distribution Network

Worldwide

METTLER TOLEDO provides full sales and service coverage worldwide. Wherever our customers are, we are the competent partner. Many global manufacturers rely on our long-standing experience to ensure the highest levels of product and process quality control.



METTLER TOLEDO Process Analytics' three producing organizations ensure faster logistics and response time to market demands in all global regions.

Distribution network

Based at several global production sites, with more than twenty market organizations, and numerous sales representatives, METTLER TOLEDO maintains a distribution network all around the world. Satisfaction of our customers is based on three pillars:

- Consulting
- Products
- After-sales service

Our highly skilled experts are at your disposal to support you in finding the best solution for your measurement application, including planning, product selection, and installation.

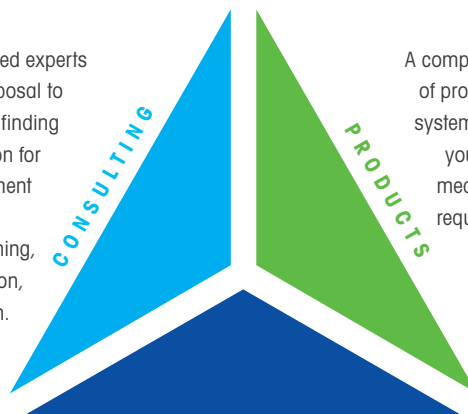

A complete range of products and systems to meet your specific measurement requirements.

AFTER-SALES SERVICE

With our customized, lifelong service management, we are able to assist in managing measurement loops throughout their entire life cycle.

INGOLD

Leading Process Analytics

THORNTON

Leading Pure Water Analytics

Process Analytics Measurement Solutions

for Industrial Applications

Table of Contents

Process Analytics Catalog

■ Introduction

About METTLER TOLEDO	4
Tools and Services	6
System Integration	8
Intelligent Sensor Management (ISM)	10

■ Ingold

■ pH

pH and ORP Systems	14
METTLER TOLEDO pH Electrodes	16
InPro 2000 (i)	18
InPro 3100 (i)	20
InPro 3250 (i)	22
InPro 4010	24
InPro 4260 (i)/InPro 4281 i	26
InPro 4550/InPro 4501	28
InPro 4800 (i)/InPro 4881 i	30
InPro 4850i	32
Puncture pH Electrodes	34
pH Buffers, Electrolytes, Cleaning and Storage Solutions	35
Pro2Go Portable pH/ORP Meter	36

■ Dissolved Oxygen

Dissolved Oxygen Measurement Systems	38
InPro 6860 i Optical Oxygen Sensor	40
Powering Accessories for InPro 6860 i	42
InPro 6960 i/InPro 6970 i Optical Oxygen Sensor	44
InPro 6800/InPro 6850 i (12 & 25 mm)	46
InPro 6900 (i)/InPro 6950 i	48
InTap: Portable Optical DO Analyzer	50
InPro 6050	52
Oxygen Accessories and Spare Parts	53

■ Dissolved Carbon Dioxide

In Situ Monitoring of Dissolved CO ₂ in Bioreactors	54
In-line CO ₂ Measurement in Beverages	55
InPro 5000 i	56
InPro 5500 i	58

■ Turbidity/Optical Density

Versatile Turbidity Measurement	60
InPro 8050/InPro 8100 (Single Fiber)	62
InPro 8200 (Dual Fiber)	64
InPro 8610i e/InPro 8630i e	66
InPro 8300 RAMS Series	68

■ Conductivity

Conductivity/Resistivity Systems	70
InPro 7000-VP	72
InPro 7100-VP	74
InPro 7100 (i)	76
InPro 7250	78

■ Transmitters

Transmitters for All Parameters	80
M200	82
M300 Process	84
M400 4-wire	86
M400 Type 1 Cond Ind	90
M800	92
M100 DIN Rail	96
M100 Sensor Mount Transmitter	97
M80 Sensor Mount Transmitter	98
M400 2-Wire	100

■ ISM Productivity Tools

iSense	104
Verification Kits	106

■ Housings

Process Connection Hardware	108
Sockets, Flanges, and Plugs	110
InFit 761 e	112
InFit 764 e	113
Product Configurator and Sensor Fit Guide for InFit 761 e/764 e	114
TL 761 Adapter	116
InFit 762 e/763 e	118

Product Configurator and Sensor Fit Guide for InFit 762e/763e	119	pH/ORP Sensors with ISM	178
InDip 500 Series	120	pHure Sensor with ISM	180
InFlow Series	122	pHure Sensor LE with ISM	182
InFlow 724-120	124	pH/ORP Housings, Buffer Solutions	184
InTrac 776e	126	Dissolved Oxygen and Ozone Sensors	
InTrac 777 e/779e	127	Oxygen Measurement Systems	186
InTrac 797 e/799e	128	Ozone Measurement Systems	187
InTrac 781/784	129	Pure Water Optical DO Sensor	188
InTrac 785/787	130	High Performance DO Sensors with ISM	190
Product Configurators and Sensor Fit Guides for InTrac Housings	131	pureO ₃ Dissolved Ozone Sensor with ISM	192
InTrac 788	134	Flow Sensors	
Automation		Paddlewheel Flow Sensors	194
EasyClean	136	Forward-Swept Impeller Sensors with Fittings	196
EasyClean Configuration	137	Vortex Flowmeters	198
EasyClean 400	138	Sanitary Flow Sensors	200
EasyClean 200e	139	Total Organic Carbon (TOC)	
EasyClean 150/100	140	Total Organic Carbon (TOC)	202
EasyClean Ordering Information	141	21CFR RecordLoc	203
Cables		4000TOC e	204
Cables and Connections	142	6000TOC i	206
Cable Terminations	143	450TOC	210
Cable Availability Cross Reference Table	144	TOC Pump Module	212
Cables	146	Microbial Detection Analyzer	
Gas Analytics		7000RMS	214
Rethinking Gas Analytics		Sodium Analyzer	
Introduction	152	2300Na Sodium Analyzer	216
Gas Oxygen Sensors and Analyzers	154	2301Na Sodium Analyzer	218
Measurement Theory	156	Silica Analyzer	
GPro 500 Sensor	158	2850Si Silica Analyzer	220
Variant Configurator	160	Ion Analyzer	
InPro 6000G Sensor Series	162	3000CS Chloride & Sulfate Analyzer	222
Thornton		Transmitters	
Conductivity/Resistivity		Transmitters for All Parameters	224
Conductivity/Resistivity Systems	166	M200	226
UniCond Conductivity/Resistivity Sensors with ISM	168	M300 Water	230
DCC1000e System with ISM	170	M800 Multi-Parameter, Multi-Channel Transmitter	234
Analog Conductivity Sensors	172	Trademark Notice	236
pH Electrodes			
pH and ORP Systems	176		



Info

General information
about the product



Quick Tip

Useful tips and
tricks for the product



Did You Know

Additional and
helpful information

METTLER TOLEDO

The Leader in Process Analytical Measurement

METTLER TOLEDO Group

METTLER TOLEDO specializes in providing precision instruments with the most comprehensive range of services on a global level. With more than 16,500 employees, the company generates annual sales of over US\$ 3.0 billion. Mettler-Toledo International Inc. has been listed on the New York Stock Exchange since 1997 (MTD).

METTLER TOLEDO instruments are used for critical research and development applications and also for quality control purposes. The pharmaceutical, micro-electronics, chemical, food & beverage, and cosmetic industries are among the principal users. METTLER TOLEDO enjoys an excellent reputation as an innovator, and currently invests more than US\$ 120 million per

year in research and development, having increased overall R & D spending. METTLER TOLEDO makes every effort to meet the highest quality standards, resolutely applying Total Quality Management at both the product and process level, but specifically as part of our support for customers to comply with international guidelines.

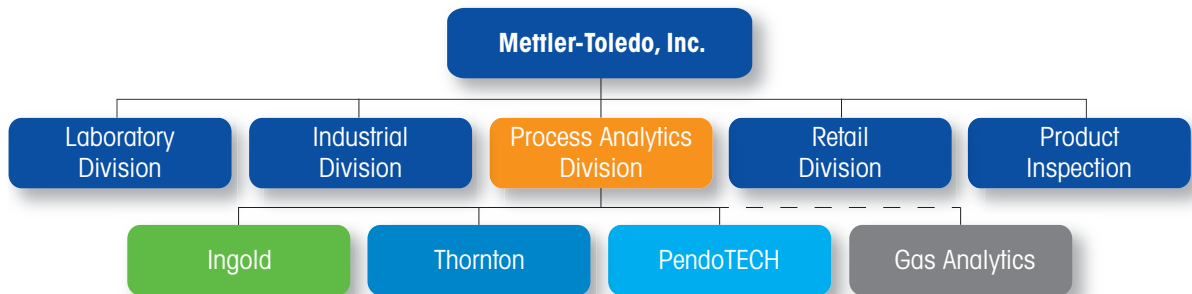

METTLER TOLEDO Process Analytics

Within the METTLER TOLEDO Group, the Process Analytics division concentrates on analytical measurement solutions for industrial manufacturing processes. The division consists of three business units: Ingold, Thornton and PendoTECH, each recognized as leaders in their respective markets and technologies.

Ingold is a worldwide leader in pH, dissolved oxygen, CO₂, conductivity and turbidity solutions for process

analytical measurement systems in chemical, food & beverage, biotechnology and pharmaceutical industries. Its core competence is high quality in-line measurement of these parameters in demanding chemical process and hygienic and sterile applications. They also provide an innovative series of TDL gas analyzers for in situ gas monitoring in industrial applications. Thornton is the leader in pure and ultrapure water monitoring instrumentation used in semiconductor,

microelectronics, power generation, pharmaceutical, and biotech applications. Its core competence is the in-line measurement of conductivity, resistivity, TOC, bioburden, dissolved oxygen and ozone in determining and controlling water purity.

PendoTECH is a leader in single-use technology for bioprocessing, with a diverse offering of pressure sensors, control systems and software for measuring, monitoring and data collection in bioprocess applications.

Ingold – Leading Process Analytics

Ingold has a long track record of innovative high-quality solutions for demanding process analytics applications.

Ingold was founded in 1948 by Dr. Werner Ingold. Today, Ingold provides the broadest range of in-line analytical measurement solutions for industrial processes in the biotechnology, pharmaceutical, chemical, and beverage industries. Ingold offers systems for the measurement para-

meters of pH/ORP, dissolved oxygen (DO), dissolved CO₂, conductivity and turbidity.

Latest developments include optical DO sensors and intelligent in-line sensor management solutions for optimized maintenance management in demanding applications.



Thornton – Leading Pure Water Analytics

Thornton is the market leader in critical ultrapure and pure water analytics, where accuracy and reliability are essential.

Thornton Inc., founded in 1963 by Dr. Richard Thornton, a Professor at Massachusetts Institute of Technology, has been part of the Process Analytics Division since 2001. Thornton offers innovative analytical instruments and sensors for the measurement of resistivity, conductivity, TOC, bioburden, pH, dissolved oxygen (DO), sodium, silica, phosphate, chloride, sulfate and ozone.

Thornton instrumentation is trusted globally in the pharmaceutical, biotech, power generation and microelectronics sectors. With the introduction of its microbial contamination analyzer, Thornton is the world's only producer of conductivity, TOC and bioburden measurement solutions for USP-regulated ultrapure waters.



Gas Analytics – Measure where it really matters

Providing innovative in situ TDL solutions for compact installations, alignment-free and easy-to-use.

In Gas Analytics we provide a broad range of in situ and at-line analytical measurement solutions for industrial processes in the chemical, petrochemical, refining and pharmaceutical industries.

Our innovative sensors and analyzers cover oxygen, carbon monoxide, car-

bon dioxide, hydrogen sulfide, hydrogen chloride, methane, ammonia and water vapor, with more parameters to come.

The employed tunable diode laser and optical technology combine high measurement accuracy with ease of installation and use.



www.mt.com/pro

Fast and Competent On-line Support

Visit our website at any time for fast and competent information. The very latest, updated product and support documentation is available in many different languages.

■ Unlimited access

What you need:

- Fast access to product documentation
- Suitable process analytical solution
- Access to certificates

What we offer:

- Information on products and measurement solutions
- Success stories about our solutions in your industry
- Country specific information and service offerings
- Personalized access
- Multilingual information
- Extensive download offerings

■ Comprehensive Expertise

www.mt.com/library

When you need analytics expertise to help you with your analytical project, METTLER TOLEDO's Expertise Library provides the content you need. In the Expertise Library includes:

- Customer Case Studies
- Expert Webinars & Interviews
- Technical White Papers
- Practical Application Notes
- Competence Guides
- Product Brochures & Datasheets

Find information on:

- Pharmaceutical processes
- Biotech and hygienic processes
- Chemical and petrochemical processes
- Water purification processes
- Wastewater applications

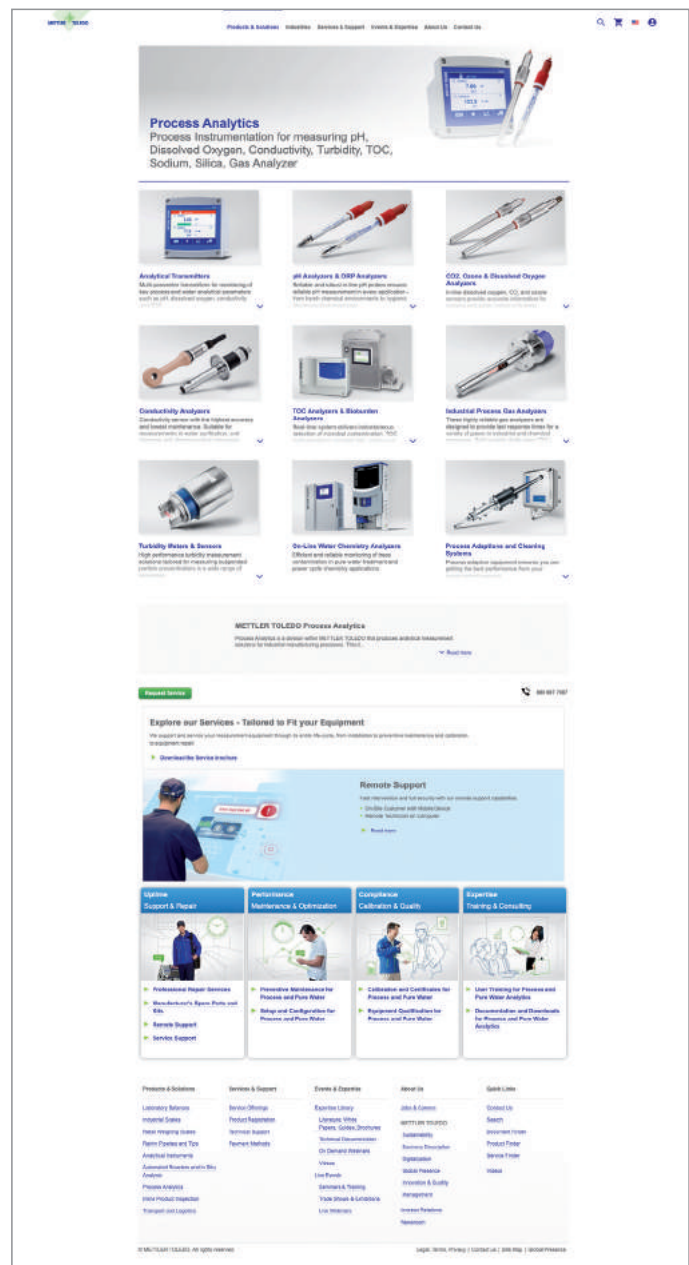

Customer Service/Technical Service

Seven Reasons to Choose METTLER TOLEDO

Customer service at METTLER TOLEDO strives to provide you with added value including professional product services as well as leading edge technical support.

Our focus is customer success

The METTLER TOLEDO organization has the largest, best-trained global service network in the industry. Our worldwide presence and reputation for outstanding quality make us the logical choice not only to provide classical services but also for services that go far beyond those of other providers.

We understand that customers today are interested in value-added solutions that give them competitive advantages in the marketplace. And that is what we endeavor to deliver. Providing the highest levels of service and customer satisfaction is very important to METTLER TOLEDO Ingold/Thornton and we understand that you expect not only the highest quality products, but also superior customer and technical support when you need it.

Service from METTLER TOLEDO goes far beyond the initial purchase. We pride ourselves in being available for you, whether it is to answer a technical question, provide details on system operation or to manage requests for service.

When you purchase products from METTLER TOLEDO you have the satisfaction of relying on proven products in your process and having a world class service organization standing behind them.

METTLER TOLEDO offers comprehensive, tailored service plans to meet your needs. Please contact your local METTLER TOLEDO representative for your individual solution.

▶ www.mt.com/contacts

Our customers benefit from

- **Quicker repairs and calibration**
- **Reliable, professional, efficient service**
- **Fast response time**
- **Higher system “uptime”**
- **Innovative and leading edge support services that meet future needs**
- **Regulatory compliance**
- **Improved productivity and enhanced competitiveness**



Asset Management and Plant Maintenance With Fieldbus and High Speed Industry Bus

Open bus integration of your process analytical measurement technology into your control system via digital fieldbus and high speed industry bus technology.

Open fieldbus protocol and industry bus such as HART, FOUNDATION fieldbus, PROFIBUS, Profinet and Ethernet/IP are currently regarded as standard in the process industry. Only bus technology enables full use of the functional advantages of digital communication to be able to achieve improved resolution of measured values, intelligent instrument diagnostics and new control strategies.

METTLER TOLEDO integration with fieldbus and high speed industry bus

These standardized communication protocols allow a central overview of the whole plant network. In addition, they offer the opportunity of comfortable instrument configuration and a higher level of process information to improve plant performance. Field process instrumentation becomes an integral part of the control and operation level. This technology provides an optimized and continuously available interface for your plant management and maintenance planning.

Integrated device descriptions

Our intelligent analytical instruments include electronic device descriptions (DD) for various process instrument configuration software tools to support seamless integration into the control and engineering level.

Bus communication in connection with asset management and predictive maintenance and information

By applying Ethernet/IP, PROFINET, HART, FOUNDATION fieldbus or PROFIBUS, seamless integration of advanced Intelligent Sensor Management (ISM) diagnostics information into your process control system is guaranteed.

The use of asset management and predictive maintenance are an important element in improving plant management. The bus technology of Ethernet/IP, PROFINET, HART, FOUNDATION fieldbus and PROFIBUS supports the online status integration information requirements in an unprecedented way.

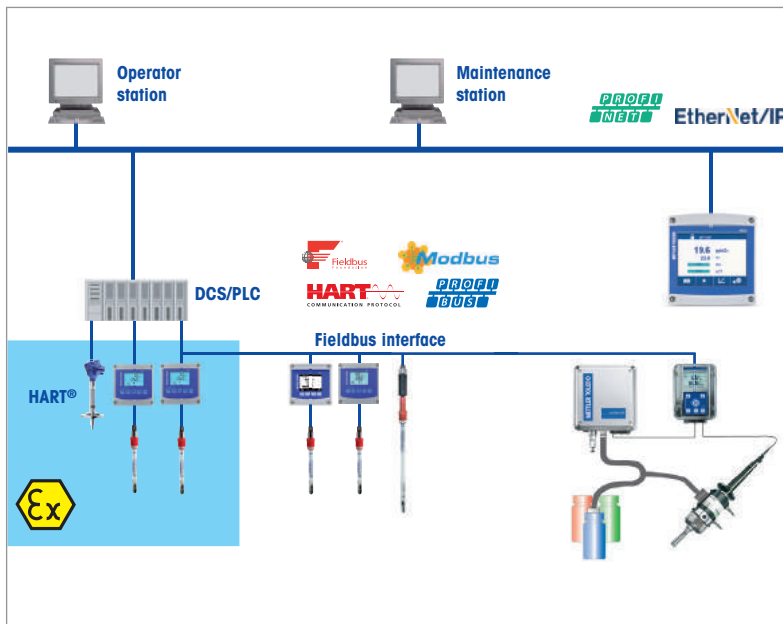



Intelligent Sensor Management

Predictive Maintenance for Process Analytics

ISM®, a breakthrough technology from METTLER TOLEDO, allows users of process analytical equipment to benefit from accurate diagnostics that predict when sensor maintenance will be required, while also increasing production process safety.

What exactly is ISM?

It is a digital technology that incorporates intelligent algorithms into sensors and analyzers. The combination of on-board microprocessors and algorithms that actually learn from

process conditions, simplifies sensor and analyzer handling and workflows. ISM delivers a level of performance that analog systems simply cannot provide, including:



Increased accuracy and measurement confidence

With ISM the process parameter value is calculated directly in the sensor, resulting in higher accuracy than analog probes. Moreover, the digital signal is unaffected by plant conditions and is stable over long cable runs, providing you with greater assurance in your processes.

Online sensor diagnostics

ISM sensors continuously check themselves for wear. Inside the probe sophisticated algorithms learn from process variables to calculate when sensor calibration or replacement will be due. The Adaptive Calibration Timer and Dynamic Lifetime Indicator allow you to use your resources more efficiently.

Easy, error-free operation

ISM sensors store their own calibration data. They can be quickly and accurately calibrated away from the process in any suitable location. When they are connected to an ISM transmitter, this data is uploaded and the transmitter configures itself automatically.

ISM sensor offering

The parameters covered by ISM sensors is wide and includes:

- pH/ORP
- dissolved oxygen
- gas phase oxygen
- dissolved carbon dioxide
- conductivity
- TOC

Reasons to switch to ISM

ISM reduces signal noise

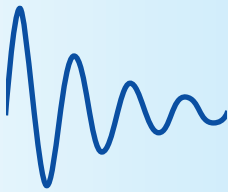

ISM lowers operating costs



ISM simplifies compliance



ISM means easy handling



Discover more reasons to switch to ISM at: www.mt.com/ism

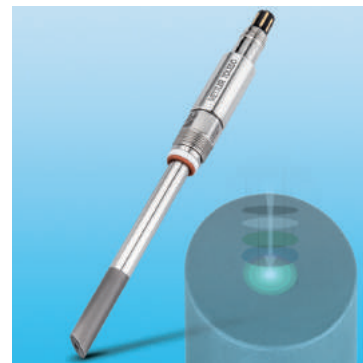

Process Analytics Measurement Solutions for Industrial Applications

pH and ORP Systems For Harsh Industrial to Pure Water Applications

With many decades of experience in designing pH/ORP electrodes, METTLER TOLEDO offers a state-of-the-art solution for practically any type of process analytical application.

Functional definition

pH can be described as a measurement of the relative acidity of a solution. Oxidation reduction potential (ORP) as measured with an ORP electrode, provides an indication of the oxidative state of the solution. It is important to measure, and often to control the pH and/or ORP of a solution for several reasons:

- To produce products with consistent well defined properties
- To efficiently produce products at optimal cost

- To avoid health risks
- To protect the environment
- To prevent physical/chemical damage to materials
- To meet regulatory requirements
- To expand scientific knowledge

The accurate measurement of pH/ORP is critical in most industries. Each application has unique physical requirements of chemical, temperature, and pressure resistance and possibly hygienic design. Another factor is what is to be done with the measurement:

monitoring only, data logging or process control.

pH electrode selection

It is important to understand the details of the application before selecting a pH electrode. The table on page 15 gives an initial glance at the various electrodes available and typical applications. Selection of a pH electrode requires a thorough knowledge of the process. Once the requirements are known, comparison of the electrode specifications detailed in this catalog will identify the appropriate sensor.



InPro 3250i



InPro 4850i



InPro 4260i



InPro 4281i

Table:
Ingold pH electrode selection guide
by industries and applications

Refer to page:	Troubleshooter (liquid) InPro 2000(O)/465	Low maintenance (mainly gel) InPro 3100(O)	InPro 3250(O) (liquid)	InPro 4800(O)/InPro 4880i	DPA	DPAS	Low maintenance (solid electrolyte) InPro 4260(O)/InPro 4280i	InPro 4501	InPro 4550	DXK	Puncture pH electrode Low maintenance (dual-membrane) InPro 4850i	
	p. 18	p. 20	p. 22	p. 30	–	–	p. 26	p. 28	p. 28	–	p. 34	p. 32
Industrial Processes												
Chemical production monitoring	•		•	•	•		•	•	•	•		
Chlorine production	•			•								•
Dyestuff production				•			•	•	•	•		
Mining				•			•	•	•	•		
Petroleum & refining	•		•	•			•	•	•			
Pulp & paper	•			•			•	•	•			
Pharmaceutical Industry												
BioPharma												
Upstream	•	•	•			•						
Downstream	•	•	•			•						
ChemPharma	•	•	•			•	•					
Food & Beverage Processes												
Brewery & beverage production	•	•	•									
Dairy												
Milk processing	•		•									
Yogurt production	•	•	•									
Cheese making	•	•	•							•	•	
Meat										•	•	
Wine	•	•	•									
Sugar & starch	•	•	•	•			•	•	•			
Yeast	•	•	•									
Cleaning solutions (CIP)		•	•									
Water Treatment												
Air scrubbers	•			•			•	•		•		
Cooling water	•		•				•	•		•		
Neutralization			•	•	•		•	•		•		
Potable water	•	•	•									
Wastewater Treatment												
Flue gas neutralization	•		•	•			•	•		•		
Galvanic wastewater			•	•	•		•	•		•		
Industrial wastewater				•			•	•		•		
Precipitation of heavy metals	•		•				•	•		•		
Sludge dewatering							•	•		•		

This table serves as an initial selection guide to suitable Ingold pH electrodes for given applications. Since

process conditions vary considerably at different stages of production, it is necessary to refer to the detailed

technical specifications of the electrode to ensure compatibility.

METTLER TOLEDO pH Electrodes

The Problem Solvers...Through 60 Years of Innovation!

The design of the pH electrode reflects the potential problems each application may present. On these two pages, application questions are raised, and the METTLER TOLEDO Ingold solutions are described.

Is frequent steam sterilization or autoclaving a requirement?

When frequent steam sterilization, autoclaving, or other dramatic process temperature cycling is encountered, the "Argenthal™" reference system maintains a constant concentration of silver chloride at the reference electrode silver wire, providing stable and repeatable reference voltages.

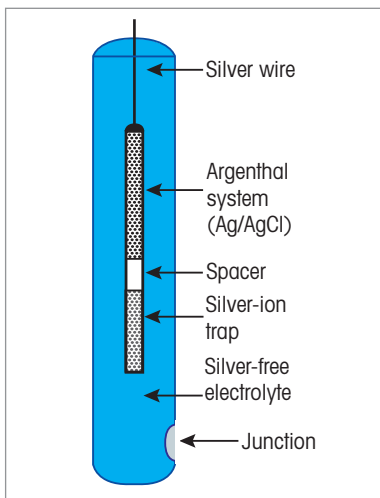

Reference electrode
Argenthal system/silver-ion trap

Does the sample contain components which could react with the reference electrolyte?

One source of problems is the reaction of silver-ions in the reference electrolyte with sulfide or other complexing compounds in the sample medium. The unique Ingold internal "silver-ion trap" prevents silver ions from entering the bulk electrolyte. Alternatively, use of "double junction" electrodes and selection of specialized electrolytes also serve to ensure chemical compatibility.

Is a watertight connection required?

The IP 68 watertight cable connection provides excellent signal transmission in all environments.



What are the temperature and pressure requirements of the installation?

Temperature and pressure requirements of a process must be met to ensure safe operation of the system as well as accurate performance of the electrode. Electrodes are available with specifications

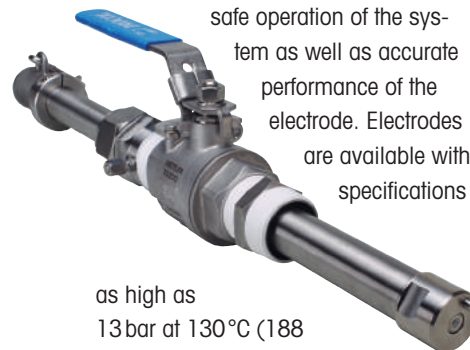

as high as
13 bar at 130°C (188
psig at 266°F) to handle
aggressive process situations.

What glass formulation is appropriate?

Numerous formulations of pH-sensitive glass have been developed to overcome application problems. "High Alkali" glass greatly reduces "sodium ion error" expanding the usable pH range from pH 12 of general purpose glass to pH 14. "Low Temperature Glass" allows continuous use at low temperatures which present high impedance problems with standard glass. "HF-resistant glass" permits use of glass electrodes at HF levels which

rapidly dissolve normal glass electrodes.

What are the physical requirements?

Among physical considerations are length, connector type, and installation. Electrodes are commonly available in lengths from 120 mm to 425 mm or longer to ensure sufficient immersion depth into the process. Improvements in electrode connector technology over the years have resulted in numerous connector configurations. Polymer body "industrial pH sensors" serve as their own housing, fitting directly into threaded connections.



Which type of reference electrolyte should be used?

Liquid reference electrolytes provide high flow through the junction keeping it clean and providing the highest accuracy and precision, and are refillable for longer life. Use of pressurized gel electrodes prevents process solutions from entering the reference electrolyte, are more compact and reduce maintenance. Solid polymer electrolytes are in direct contact with the sample medium without requiring a ceramic junction, eliminating fouling problems.

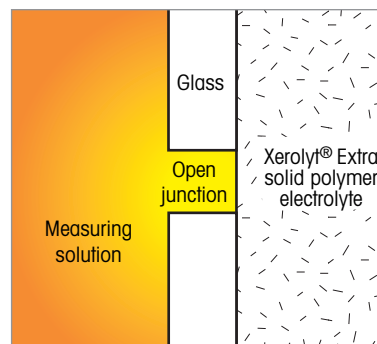

InPro 2000 (i) For the Most Extreme Requirements

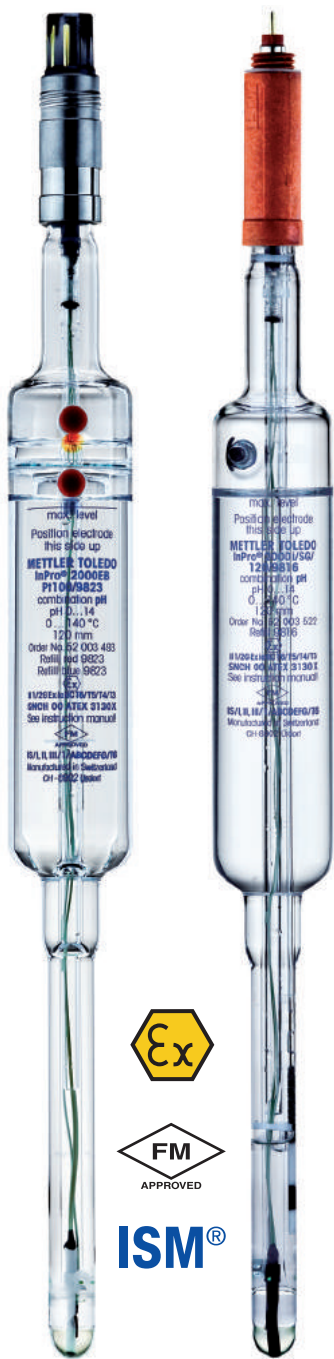

InPro 2000

InPro 2000i/SG

The InPro 2000 (i) is a combination pH electrode with an integral temperature sensor designed for highly demanding applications. Three liquid electrolytes are available adding versatility; 3M KCl is a classic electrolyte offering high flow for improved junction cleaning, Viscolyt™ has limited flow for reduced maintenance needs, and Friscolyt™ is ideal for process media with high protein or organic solvent content, and in low temperatures. Applications range from biotechnical processes requiring in-situ sterilization to dirty industrial processing chemicals.

Specifications

pH range	0 – 14 pH
Temperature	0 to 140 °C (32 to 284 °F)
Operating pressure	0 to 6 barg, 0 to 87 psig (in pressurized housing)
Cable connection	ISM: K8S; Analog: VP
Process connection	METTLER TOLEDO Housing Adapter
Reference system	Argenthal with silver-ion trap
Type of junction	Ceramic junction
Reference electrolyte	Selectable; 3M KCl, Viscolyt, or Friscolyt
Lengths	120 mm, 150 mm, 250 mm, 450 mm
Lower shaft diameter	12 mm
Temperature sensor	ISM: Digital; Analog: Pt 100 or Pt 1000
Sterilizable	Yes
Autoclavable	Yes
pH membrane	High alkali glass (HA)

Certificates and Approvals METTLER TOLEDO Quality Certificate, Pressure Equipment Directive guidelines (PED) 97/23/EC, ATEX: Ex ia IIC T6/T5/T4/T3 Ga/Gb, FM: IS Cl. I, II, III, Div 1, GR ABCDEFG/T6

Intelligent Sensor Management (ISM)

pH electrodes with integrated ISM functionality allow Plug and Measure and advanced diagnostics. ISM simplifies the installation, handling and maintenance of measurement equipment. For more information see ISM introduction pages 10–11.

Features Overview

- User-selectable reference solution allows optimum compatibility with process media
- Flowing liquid electrolyte ensures fast response and accurate pH measurement
- Silver-ion trap prevents sulfide poisoning of junction
- Refillable electrolyte extends operational life
- Domed glass membrane impedes bubble formation for greater reliability
- Watertight connector (IP 68)
- Integral temperature sensor, more accurate temperature compensation
- ATEX and FM certification for hazardous areas

► www.mt.com/InPro2000

Ordering Information

ISM Electrodes	Length	Electrolyte	Temp. Signal	Order Number
InPro 2000i/SG	120mm	3M KCl	Digital	52 003 521
InPro 2000i/SG	150mm	3M KCl	Digital	30 068 948
InPro 2000i/SG	250mm	3M KCl	Digital	30 068 949
InPro 2000i/SG	450mm	3M KCl	Digital	30 069 160
InPro 2000i/SG	120mm	Viscolyt	Digital	52 003 522
InPro 2000i/SG	150mm	Viscolyt	Digital	52 003 523
InPro 2000i/SG	250mm	Viscolyt	Digital	52 003 524
InPro 2000i/SG	450mm	Viscolyt	Digital	52 003 525
InPro 2000i/SG	120mm	Friscolyt	Digital	52 003 526
InPro 2000i/SG	150mm	Friscolyt	Digital	52 003 527
InPro 2000i/SG	250mm	Friscolyt	Digital	52 003 528
InPro 2000i/SG	450mm	Friscolyt	Digital	52 003 529
Analog Electrodes				
InPro 2000	120mm	Viscolyt	Pt 100	52 001 426
InPro 2000	120mm	Viscolyt	Pt 1000	52 001 427
InPro 2000	250mm	Viscolyt	Pt 100	52 001 428
InPro 2000	250mm	Viscolyt	Pt 1000	52 001 429
InPro 2000	450mm	Viscolyt	Pt 100	52 001 738
InPro 2000	450mm	Viscolyt	Pt 1000	52 001 792
InPro 2000	120mm	3M KCl	Pt 100	52 001 430
InPro 2000	120mm	3M KCl	Pt 1000	52 001 431
InPro 2000	250mm	3M KCl	Pt 100	52 001 432
InPro 2000	250mm	3M KCl	Pt 1000	52 001 433
InPro 2000	450mm	3M KCl	Pt 100	52 001 794
InPro 2000	450mm	3M KCl	Pt 1000	52 001 777
InPro 2000	120mm	Friscolyt	Pt 100	52 001 434
InPro 2000	120mm	Friscolyt	Pt 1000	52 001 435
InPro 2000	250mm	Friscolyt	Pt 100	52 001 436
InPro 2000	250mm	Friscolyt	Pt 1000	52 001 437
InPro 2000	450mm	Friscolyt	Pt 100	52 001 655
InPro 2000	450mm	Friscolyt	Pt 1000	52 001 666

InPro 2000 (i) Electrolytes

To cope optimally with the conditions prevailing in different types of chemical processes, a wide variety of electrolytes is available:

9816 Viscolyt

Mostly frequently used CP electrolyte with limited outflow and therefore long refill intervals.

9823 KCl

Classic electrolyte with high electrolyte outflow for improved diaphragm cleaning.

9848 Friscolyt

Used for media with proteins/organic solvent content.

Did You Know

The InPro 2000 (i) is the next generation of the 465 style electrode featuring temperature compensation and VP connection. For other connectors and styles, the 465 also is available. For further information please contact your local sales organization.

Suitable Housings	p.
InFit 763 e.....	118
InFit 764 e.....	113
InTrac 776 e.....	126
InTrac 784	129

InPro 3100 (i) Versatile and Robust



InPro 3100

InPro 3100i



Also available for upside-down installation as InPro 3100 (i) UD.

The InPro 3100 (i) is a combined pH electrode and temperature sensor designed specially for in-line pH measurements in bio-processes where CIP and SIP are used. This rugged gel-filled electrode leads the industry for fast and precise measurements, even after repeated autoclaving or sterilization cycles at 140 °C (284 °F). The electrode utilizes METTLER TOLEDO's silver-ion trap, keeping the reference junction clear even in the presence of sulfide-bearing solutions. With the InPro 3100 (i) UD, upside-down mounting is possible.

Specifications

pH range	0–14 pH	
Temperature	InPro 3100 (i):	0 to 80 °C (32 to 176 °F) for operation 0 to 140 °C (32 to 284 °F) for sterilization
	InPro 3100 (i) UD:	0 to 80 °C (32 to 176 °F) for operation 0 to 130 °C (32 to 266 °F) for sterilization
Operating pressure	0 to 6 barg @ 140 °C (0 to 87 psig @ 284 °F)	
Cable connection	ISM: K8S; Analog: VP	
Process connection	Pg 13.5 thread	
Reference system	Argentinal with silver-ion trap	
Type of junction	Ceramic junction	
Reference electrolyte	Gel	
Lengths	120 mm, 150 mm, 225 mm, 325 mm, 425 mm	
Shaft diameter	12 mm	
Temperature sensor	ISM: Digital;	
	Analog: Pt 100 or Pt 1000	
Sterilizable	Yes	
Autoclavable	Yes	
pH membrane	High alkali glass (HA)	

Certificates and Approvals METTLER TOLEDO Quality Certificate, Pressure Equipment Directive guidelines (PED) 97/23/EC, ATEX: Ex ia IIC T6/T5/T4/T3 Ga/Gb, FM: IS Cl. I, II, III, Div 1, GR ABCDEFG/T6

Intelligent Sensor Management (ISM)

pH electrodes with integrated ISM functionality allow Plug and Measure and advanced diagnostics. ISM simplifies the installation, handling and maintenance of measurement equipment. For more information see ISM introduction pages 10–11.

Features Overview

- Fully autoclavable or sterilizable in-situ
- Gel electrolyte reduces maintenance
- Resistant to poisoning substances
- EHEDG certified
- Pressure resistant up to 6 barg (87 psig)
- Watertight connector (IP68)
- Integral temperature sensor permits automatic temperature compensation

► www.mt.com/InPro3100

Ordering Information

ISM Electrodes	Length	Temp. Signal	Order Number
InPro 3100i/SG	120 mm	Digital	52 003 515
InPro 3100i/SG	150 mm	Digital	52 003 516
InPro 3100i/SG	225 mm	Digital	52 003 517
InPro 3100i/SG	325 mm	Digital	30 090 877
InPro 3100i/SG	425 mm	Digital	30 091 063
InPro 3100iUD	120 mm	Digital	52 005 433
InPro 3100iUD	225 mm	Digital	52 003 583
Analog Electrodes			
InPro 3100	120 mm	Pt 100	52 000 656
InPro 3100	120 mm	Pt 1000	52 000 658
InPro 3100UD	120 mm	Pt 100	52 002 531
InPro 3100UD	120 mm	Pt 1000	52 002 752
InPro 3100	150 mm	Pt 100	52 000 659
InPro 3100	150 mm	Pt 1000	52 000 660
InPro 3100	225 mm	Pt 100	52 000 661
InPro 3100	225 mm	Pt 1000	52 000 662
InPro 3100UD	225 mm	Pt 100	52 005 354
InPro 3100	325 mm	Pt 100	52 000 663
InPro 3100	325 mm	Pt 1000	52 000 664
InPro 3100	425 mm	Pt 100	52 000 665
InPro 3100	425 mm	Pt 1000	52 000 666



Did You Know

All pH electrodes, even those with gel or solid polymer reference systems, contain a liquid electrolyte in the pH half cell which must be in contact with the internal silver wire in order for the sensor to measure accurately. Sensors therefore must be installed at least 15° from horizontal to prevent air bubble interference. Exception: the InPro 3100 (i) UD “upside-down” electrode.

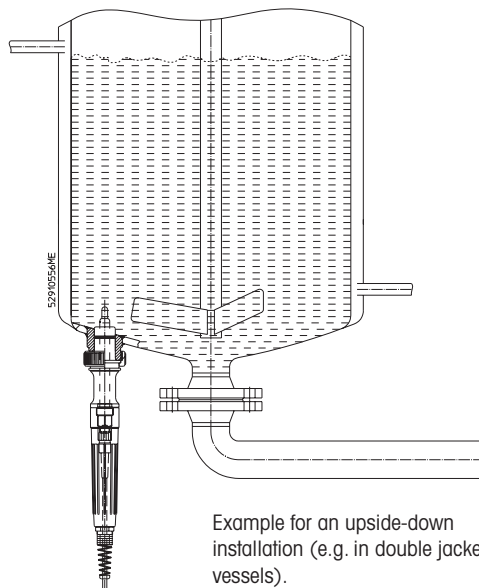

Example for an upside-down installation (e.g. in double jacket vessels).

Suitable Housings

	p.
InFit 761 e	112
InFit 762 e	118
InDip	120
InTrac 777 e	127
InTrac 797 e	128
InTrac 781	129
InTrac 785/787	130

InPro 3250 (i) Highest Performance, Highest Accuracy



InPro 3253

InPro 3250i

Features Overview

- Fully autoclavable or sterilizable in-situ (InPro 3250 (i), InPro 3253 (i))
- Pressurized electrolyte reduces maintenance
- MaxCert™, including biocompatibility according to USP 26, Chapter 87

The InPro 3250 (i) family is a pre-pressurized, liquid-filled, low-maintenance pH sensor and temperature sensor for in-line measurements in demanding applications. Its durable design is well suited for harsh chemical process conditions or to meet the stringent demands of sterile biotech applications where CIP and SIP are used. These rugged electrodes lead the industry for fast and precise measurements, even after repeated autoclaving or sterilization cycles at 140 °C (284 °F). The InPro 3250 (i) family is available with an expanded selection of different pH-sensitive glass membranes. This guarantees the best possible measurement performance under the most diverse operating conditions, both in chemical and biotech processes. The platinum-auxiliary electrode (solution ground) which functions to eliminate ground loop problems, allows for use of advanced sensor diagnostics, or can be used as an ORP (redox) sensor. Also available with Intelligent Sensor Management (ISM) for Plug and Measure and advanced diagnostics.

Specifications

pH range	0 – 14 pH InPro 3250 (i); 0 – 12 pH InPro 3253 (i); 1 – 11 pH InPro 3251 (i), InPro 3252
Temperature	0 to 100 °C (32 to 212 °F) InPro 3250 (i), InPro 3253 (i); –25 to 80 °C (–13 to 176 °F) InPro 3251 (i); 0 to 80 °C (32 to 176 °F) InPro 3252
Operating pressure	0 to 4 barg (0 to 58 psig)
Cable connection	ISM: K8S; Analog: VP
Process connection	Pg 13.5 thread
Reference system	Argenthal with silver-ion trap
Type of junction	Ceramic junction
Reference electrolyte	Pre-pressurized liquid
Lengths	120 mm, 225 mm, 325 mm, 425 mm
Shaft diameter	12 mm
Temperature sensor	ISM: digital Analog: Pt 100 or Pt 1000
Sterilizable	Yes, up to 140 °C (284 °F)
Autoclavable	Yes
pH membrane	Various by applications
Certificates and Approvals	METTLER TOLEDO Quality Certificate, Pressure Equipment Directive guidelines (PED) 97/23/EC, ATEX: Ex ia IIC T6/T5/T4/T3 Ga/Gb, FM: IS Cl. I, II, III, Div 1, GR ABCDEFG/T6

Intelligent Sensor Management (ISM)

pH electrodes with integrated ISM functionality allow Plug and Measure and advanced diagnostics. ISM simplifies the installation, handling and maintenance of measurement equipment. For more information see ISM introduction pages 10–11.

Ordering Information

ISM Electrodes	Length	Temp. Signal			Order Number
– with alkali resistant glass					
InPro 3250i/SG	120mm	Digital			52 005 373
InPro 3250i/SG	225mm	Digital			52 005 374
InPro 3250i/SG	325mm	Digital			52 005 375
InPro 3250i/SG	425mm	Digital			52 005 376
– for applications at low temperatures					
InPro 3251 i/SG	120mm	Digital			52 003 693
– with steam sterilizable glass					
InPro 3253i/SG	120mm	Digital			52 005 377
InPro 3253i/SG	225mm	Digital			52 005 378
InPro 3253i/SG	325mm	Digital			52 005 379
InPro 3253i/SG	425mm	Digital			52 005 380
Analog Electrodes	Length	Temp. Signal	Order Number	Temp. Signal	Order Number
– with alkali resistant glass					
InPro 3250	120mm	Pt 100	52 002 547	Pt1000	52 002 548
InPro 3250	225mm	Pt 100	52 002 552	Pt1000	52 002 553
InPro 3250	325mm	Pt 100	52 002 554	Pt1000	52 002 555
InPro 3250	425mm	Pt 100	52 002 556	Pt1000	52 002 557
InPro 3250SG	120mm	Pt 100	52 002 558	Pt1000	52 002 559
InPro 3250SG	225mm	Pt 100	52 002 560	Pt1000	52 002 561
InPro 3250SG	325mm	Pt 100	52 002 562	Pt1000	52 002 563
InPro 3250SG	425mm	Pt 100	52 002 564	Pt1000	52 002 565
– for applications at low temperatures					
InPro 3251	120mm	Pt 100	52 002 585	–	–
InPro 3251	225mm	Pt 100	52 002 586	–	–
– for applications in hydrofluoric acid cont. media					
InPro 3252	120mm	Pt 100	52 002 587	–	–
InPro 3252	225mm	Pt 100	52 002 588	–	–
InPro 3252	250mm	Pt 100	52 002 589	–	–
– with steam sterilizable glass					
InPro 3253	120mm	Pt 100	52 002 566	Pt1000	52 002 567
InPro 3253	225mm	Pt 100	52 002 568	Pt1000	52 002 569
InPro 3253	250mm	Pt 100	52 002 570	–	–
InPro 3253	325mm	Pt 100	52 002 571	Pt1000	52 002 572
InPro 3253	425mm	Pt 100	52 002 573	Pt1000	52 002 574
InPro 3253SG	120mm	Pt 100	52 002 576	Pt1000	52 002 577
InPro 3253SG	225mm	Pt 100	52 002 578	Pt1000	52 002 579
InPro 3253SG	325mm	Pt 100	52 002 580	Pt1000	52 002 581
InPro 3253SG	425mm	Pt 100	52 002 582	Pt1000	52 002 583

InPro Sensor Designation

The last digit of the InPro designation indicates the

pH glass type:

00: High alkali glass (HA)

01: Low temperature glass (LoT)

02: Hydrofluoric acid resistant glass (HF)

03: Steam sterilizable glass (A41)

Suitable Housings

	p.
InFit 761 e	112
InFit 762 e	118
InFlow	122
InDip	120
InTrac 777 e	127
InTrac 797 e	128
InTrac 781	129
InTrac 785/787	130



InPro 4010

With Solid Polymer Electrolyte



The InPro 4010 is a low maintenance, economical pH sensor targeted towards industrial wastewater processes. Available with an internal temperature sensor which provides accurate temperature reading and compensation in a single unit. The solid polymer electrolyte is in direct contact with the sample medium, eliminating potential for junction fouling. The plastic body makes this a rugged sensor with reliable performance in contaminated liquids.

Specifications

pH range	2 – 12 pH
Temperature	0 to 60 °C (32 to 140 °F)
Operating pressure	1 barg at 60 °C (15 psig @ 140 °F)
Cable connection	VP
Process connection	Pg 13.5 thread
Reference system	Argenthal
Type of junction	Open aperture, double junction
Reference electrolyte	Solid polymer
Lengths	120 mm
Shaft diameter	12 mm
Temperature sensor	Pt 100, Pt 1000 or none
Sterilizable	No
Autoclavable	No
pH membrane	General purpose glass
Certificates and Approvals	METTLER TOLEDO Quality Certificate

Ordering Information

pH Electrodes	Length	Temperature Sensor	Order Number
InPro 4010	120 mm	Pt 100	52 000 511
InPro 4010	120 mm	Pt 1000	52 000 512
InPro 4010	120 mm	None	52 000 510

For pH buffers, refer to "pH and Redox Accessories" section.

For cables, cable lengths and for terminating connectors, refer to "Cables" section on pages 142 – 149.

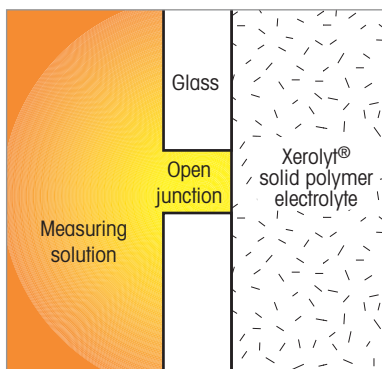

Open reference junction

Features Overview

- Open aperture junction resists fouling
- Solid polymer electrolyte requires no refilling, reduces maintenance
- Double junction reference design resists poisoning
- VarioPin Connector – IP 68, Easy connection, excellent signal transmission
- Integral temperature sensor permits automatic temperature compensation
- Plastic body prevents breakage

Suitable Housings	p.
InFit 761e	112
InFit 762e	118
InFlow	122
InDip	120
InTrac 777 e	127
InTrac 785/787	130

► www.mt.com/InPro4010

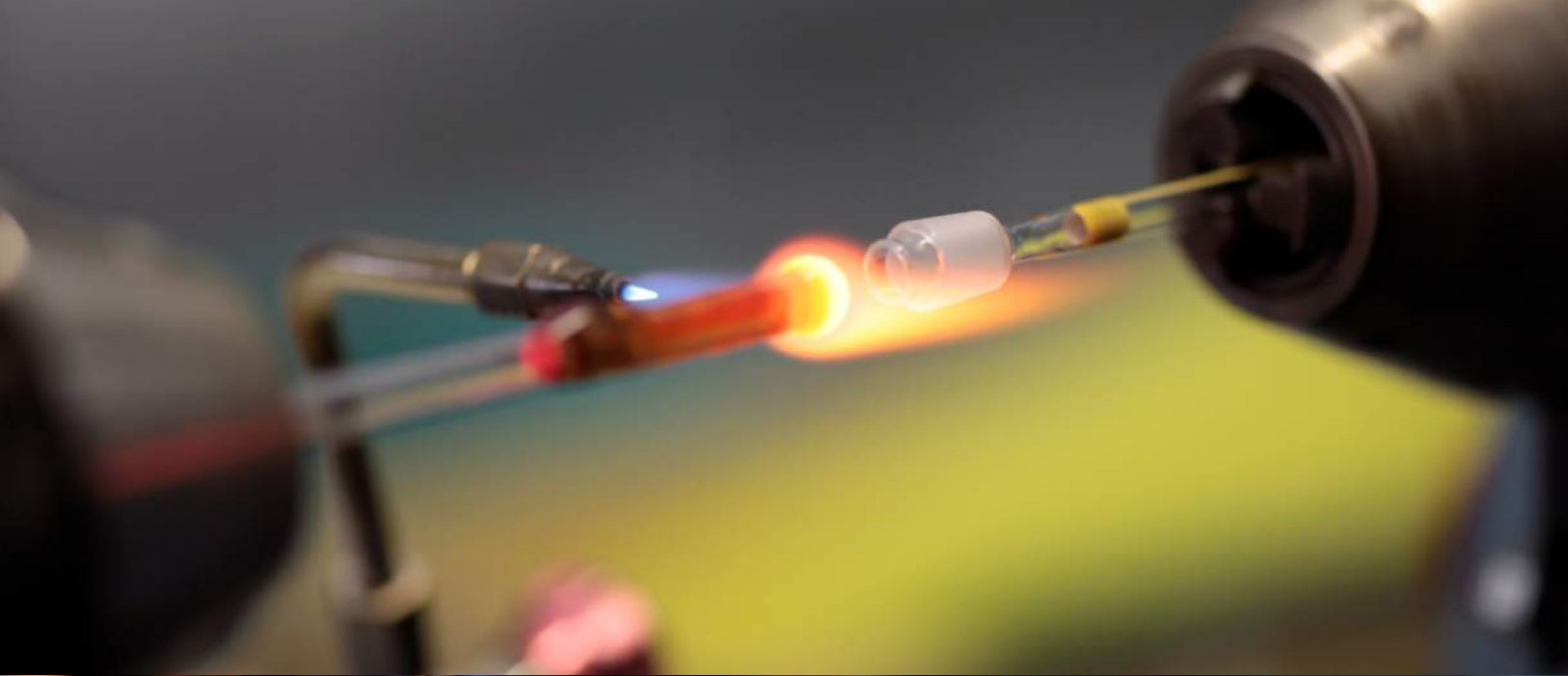

InPro 4260 (i)/InPro 4281 i

Reliable, Long-lasting Electrodes



InPro 4260i

InPro 4281i

The InPro 4260 (i)/InPro 4281 i is a combined pH electrode and temperature sensor family designed for highly demanding chemical applications. InPro 4260 (i)/InPro 4281 i electrodes feature Xerolyt® Extra polymer reference electrolyte for precise pH measurement and longer lifetime, even under the most difficult industrial environments. Also available with Intelligent Sensor Management (ISM) for Plug and Measure and advanced diagnostics.

Specifications

pH range	0–14 pH InPro 4260 (i); 1–14 pH InPro 4262(i), InPro 4281 (i)
Temperature	InPro 4260 (i), InPro 4281 i: 0 to 130°C (32 to 266 °F) InPro 4262 (i): 0 to 80°C (32 to 176 °F)
Operating pressure	15 barg @ 25 °C, 7 barg @ 130 °C (0 to 217 psig @ 77 °F, 101 psig @ 266 °F)
Cable connection	ISM: K8S; Analog: VP
Process connection	Pg 13.5 thread
Reference system	Argenthal
Type of junction	Open junction with direct contact to media
Reference electrolyte	Xerolyt® Extra
Lengths	120 mm, 225 mm, 425 mm
Shaft diameter	12 mm
Shaft materials	InPro 426x (i): Glass; InPro 428xi: Titanium
Temperature sensor	ISM: Digital; Analog: Pt100 or Pt1000
Sterilizable	No
Autoclavable	No
pH membrane	Various by applications
Solution ground	InPro 426x (i): Platinum; InPro 428xi: Titanium
Certificates and Approvals	METTLER TOLEDO Quality Certificate, Pressure Equipment Directive guidelines (PED) 97/23/EC, ATEX: Ex ia IIC T6/T5/T4/T3 Ga/Gb, FM: IS Cl. I, II, III, Div 1, GR ABCDEFG/T6 EN 10204-3.1 (InPro 4281 i)

Intelligent Sensor Management (ISM)

pH electrodes with integrated ISM functionality allow Plug and Measure and advanced diagnostics. ISM simplifies the installation, handling and maintenance of measurement equipment. For more information see ISM introduction pages 10–11.

Features Overview

- Xerolyt polymer electrolyte
- Open junction eliminates clogging
- Resistant to poisoning substances
- Expanded pH range covers 0–14 pH
- Resistant to solvents, strong acids and alkali
- Domed glass membrane impedes bubble formation for greater reliability
- Watertight connector (IP68), integral temperature sensor
- ATEX and FM certified for hazardous areas
- InPro 4281 i electrode is made with a rugged titanium shaft, providing exceptional chemical resistance and durability.
- InPro 4281i features a flat pH membrane suited for fibers and high solids samples

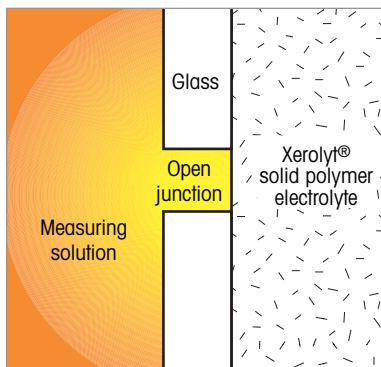

Open reference junction

► www.mt.com/InPro4260

Ordering Information

ISM Electrodes	Length	Temp. Signal	Order Number
InPro 4260 i/SG	120 mm	Digital	52 005 381
InPro 4260 i/SG	225 mm	Digital	52 005 382
InPro 4260 i/SG	425 mm	Digital	52 005 407
InPro 4262 i/SG	120 mm	Digital	30 018 467
InPro 4262 i/SG	225 mm	Digital	30 018 468
InPro 4281 i/SG	120 mm	Digital	30 301 402
InPro 4281 i/SG	225 mm	Digital	30 301 403
InPro 4281 i/SG	425 mm	Digital	30 301 404
Analog Electrodes			
InPro 4260	120 mm	Pt 100	52 002 986
InPro 4260	120 mm	Pt 1000	52 002 987
InPro 4260	225 mm	Pt 100	52 002 988
InPro 4260	225 mm	Pt 1000	52 002 989
InPro 4260	425 mm	Pt 100	52 002 992
InPro 4260	425 mm	Pt 1000	52 002 993
InPro 4260 SG	120 mm	Pt 100	52 003 545
InPro 4260 SG	120 mm	Pt 1000	52 003 546
InPro 4260 SG	225 mm	Pt 100	52 003 547
InPro 4260 SG	225 mm	Pt 1000	52 003 548
InPro 4262	120 mm	Pt 100	52 003 549
InPro 4262	120 mm	Pt 1000	52 003 550
InPro 4262	225 mm	Pt 100	52 003 551
InPro 4262	225 mm	Pt 1000	52 003 552
InPro 4262	425 mm	Pt 100	52 003 553
InPro 4262	425 mm	Pt 1000	52 003 554



Did You Know

The InPro 4260 (i) family now also includes a hydrofluoric acid resistant glass formulation. Solution ground stabilizes the high impedance pH signal and provides an additional reference point for sensor diagnostics which can detect changes in performance due to influence of the media.



InPro Sensor Designation

The last digit of the InPro designation indicates the pH glass type:

- 00 – High alkali glass (HA)
- 01 – Low temperature glass (LoT)
- 02 – Hydrofluoric acid resistant glass (HF)
- 03 – Steam sterilizable glass (A41)

Suitable Housings	p.
InFit 761 e.....	112
InFit 762 e.....	118
InFlow	122
InDip	120
InTrac 777 e.....	127
InTrac 797 e.....	128
InTrac 781	129
InTrac 785/787	130

InPro 4550/InPro 4501

The Rugged Solution



InPro 4550

InPro 4501 VP



The InPro 4550/4501 are rugged, low maintenance, combination pH/temperature sensors, designed to handle harsh chemical processes and industrial wastewater applications. The durable polymer body houses a solid polymer reference electrolyte, making the electrode robust from both physical and chemical attack. A solution ground prevents ground loop problems and allows advanced sensor diagnostics. The solid polymer electrolyte is in direct contact with the sample medium, eliminating potential for junction fouling. The InPro 4501's flat glass pH membrane is protected against breakage and is self-cleaning in flowing applications. The higher pressure/temperature specifications of the InPro 4550 target demanding applications with heavily contaminated media and aggressive industrial chemicals.

Specifications

	InPro 4550	InPro 4501
pH range	0–14 pH	1–14 pH
Temperature	0 to 130 °C (32 to 266 °F)	0 to 100 °C (32 to 212 °F)
Operating pressure	0 to 7 barg @ 130 °C (0 to 101 psig @ 266 °F)	0 to 6 barg @ 65 °C (0 to 87 psig @ 149 °F)
Cable connection	VP	VP or fixed cable
Process connection	1" MNPT	1" MNPT
Reference system	Argenthal	Argenthal
Type of junction	Open aperture, double junction	Open aperture, double junction
Reference electrolyte	Xerolyt Extra, solid polymer	Xerolyt Extra, solid polymer
Solution ground	Titanium	Titanium
Immersion length	72.5 mm (from front threads)	72.5 mm (from front threads)
Process connection	1" MNPT, 2-places	1" MNPT, 2-places
Temperature sensor	Pt 100, Pt 1000	Pt 100, Pt 1000
Body material	PPS (polyphenylene sulfide)	PVDF
Sterilizable	No	No
Autoclavable	No	No
pH membrane	High alkali glass (HA)	Flat membrane with low temperature glass (LoT)

Certificates and Approvals	METTLER TOLEDO Qual. Cert., Pressure Equipment Directive guidelines (PED) 97/23/EC, ATEX: Ex ia IIC T6/T5/T4/T3 Ga/Gb, FM: IS Cl. I, II, III, Div 1, GR ABCDEFG/T6	METTLER TOLEDO Qual. Cert.
----------------------------	--	----------------------------

Features Overview

- Withstands high process temperature and pressure (InPro 4550)
- PPS body is highly resistant to chemical attack (InPro 4550)
- Open aperture junction resists fouling
- Solid polymer electrolyte requires no refilling, reduces maintenance
- Watertight connector (IP 68) for easy connection and excellent signal transmission
- Dual NPT threads allow direct mounting into process
- Solution ground allows sensor diagnostics and eliminates ground loop problems

▶ www.mt.com/InPro4550
▶ www.mt.com/InPro4501

Ordering Information

Electrode	Connection	Cable Length	Temperature Sensor	Order Number
InPro 4550				
InPro 4550	VarioPin	N/A	Pt100	52 002 401
InPro 4550	VarioPin	N/A	Pt1000	52 002 402
InPro 4501				
InPro 4501	VarioPin	N/A	Pt100	59 909 570
InPro 4501	VarioPin	N/A	Pt1000	59 909 571
InPro 4501	Fixed cable	3m (9.8ft)	Pt100	59 909 542
InPro 4501	Fixed cable	3m (9.8ft)	Pt1000	59 909 545
InPro 4501	Fixed cable w/BNC	3m (9.8ft)	Pt100	59 909 543
InPro 4501	Fixed cable	10m (32.8ft)	Pt100	59 909 546
InPro 4501	Fixed cable	10m (32.8ft)	Pt1000	59 909 548
Accessory				
Protective sleeve				52 401 808

For pH buffers, refer to “pH and Redox Accessories” section.

For cables, cable lengths and for terminating connectors, refer to “Cables” section on pages 142–149.



Did You Know

The protective sleeve for the InPro 4550 and InPro 4501 keeps the connection clean in dirty environments and protects the cable from stress.



Slotted tip protects the pH glass membrane



Flat glass pH membrane and solution ground

Suitable Housings	p.
InDip 550	120

InPro 4800 (i)/InPro 4881 i For Harsh Environments



InPro 4800 i



InPro 4881 i

The InPro 4800 (i)/InPro 4881 i is the top-of-the-line combined pH and temperature electrode family designed to handle high-temperature and high-pressure dirty chemical applications. The strong resistance to oxidizing media, solvents, acid and alkali solutions make it suitable for highly demanding industrial applications including chemical processing, chlor-alkali, pulp and paper, dyes and pigments, and sugar processing.

Also available with Intelligent Sensor Management (ISM) for Plug and Measure and advanced diagnostics.

Specifications

pH range	0–14 pH InPro 4800 (i); 1–14 pH InPro 4801 (i), InPro4881 i 1–11 pH InPro 4802 (i)
Temperature	InPro 4800 (i), InPro 4801 (i), InPro 4881 i: –5 to 130 °C (23 to 266 °F) InPro 4802 (i): 0 to 80 °C (32 to 176 °F)
Operating pressure	12 barg @ 130 °C (174 psig @ 266 °F)
Cable connection	ISM: K8S; Analog: VP
Process connection	Pg 13.5 thread
Reference system	Ag/AgCl system, pressure-compensated double gel-electrolyte chambers
Type of junction	Exterior: PTFE annular diaphragm Interior: Non-flow ceramic diaphragm
Reference electrolyte	Gel
Lengths	120 mm, 225 mm, 425 mm
Shaft diameter	12 mm
Shaft materials	InPro 480x (i): Glass InPro 488x i: Titanium
Temperature sensor	ISM: Digital; Analog: Pt 100 or Pt 1000
pH membrane	Various by applications
Solution ground	InPro 480x (i): Platinum InPro 488x i: Titanium
Sterilizable	No
Autoclavable	No
Glass membrane	InPro 4800: Cylindrical, high alkali quality glass InPro 4801 SG, InPro 4881 i: Flat, low impedance quality glass

Certificates and Approvals METTLER TOLEDO Quality Certificate
Pressure Equipment Directive guidelines (PED) 97/23/EC,
ATEX: Ex ia IIC T6/T5/T4/T3 Ga/Gb,
FM: IS Cl. I, II, III, Div 1, GR ABCDEFG/T6
EN 10204-3.1 (InPro 4281 i)

Intelligent Sensor Management (ISM)

pH electrodes with integrated ISM functionality allow Plug and Measure and advanced diagnostics. ISM simplifies the installation, handling and maintenance of measurement equipment. For more information see ISM introduction pages 10–11.

Ordering Information

ISM Electrodes	Length	Temp. Signal	Order Number
InPro 4800 i/SG	120 mm	Digital	52 005 383
InPro 4800 i/SG	225 mm	Digital	52 005 384
InPro 4800 i/SG	425 mm	Digital	52 003 748
InPro 4801 i/SG	120 mm	Digital	52 003 581
InPro 4801 i/SG	225 mm	Digital	30 069 539
InPro 4801 i/SG	425 mm	Digital	52 003 857
InPro 4802 i/SG	120 mm	Digital	52 003 696
InPro 4802 i/SG	225 mm	Digital	52 003 697
InPro 4881 i/SG	120 mm	Digital	30 301 405
InPro 4881 i/SG	225 mm	Digital	30 301 406
InPro 4881 i/SG	425 mm	Digital	30 301 407

Analog Electrodes

InPro 4800	120 mm	Pt 100	52 002 124
InPro 4800	120 mm	Pt 1000	52 002 125
InPro 4800 SG	120 mm	Pt 100	52 003 541
InPro 4800 SG	120 mm	Pt 1000	52 003 542
InPro 4800	225 mm	Pt 100	52 002 126
InPro 4800	225 mm	Pt 1000	52 002 127
InPro 4800 SG	225 mm	Pt 100	52 003 543
InPro 4800 SG	225 mm	Pt 1000	52 003 544
InPro 4800	425 mm	Pt 100	52 002 129
InPro 4800	425 mm	Pt 1000	52 002 130
InPro 4801 SG	120 mm	Pt 100	52 002 131
InPro 4801 SG	120 mm	Pt 1000	52 002 132
InPro 4802	225 mm	Pt 100	52 002 718
InPro 4802 SG	225 mm	Pt 1000	52 003 398

Features Overview

- High pressure/high temperature rating 12 barg @ 130 °C (174 psig @ 266 °F)
- Very long diffusion path using two electrolyte chambers
- PTFE annular junction repels dirt
- Resistant to strong oxidizing agents, solvents, acids and alkali, and to poisoning substances
- Watertight connector (IP 68), integral temperature sensor
- InPro 4801 (i) and InPro 4881 i feature a flat pH membrane suited for fibers and high solids samples
- ATEX and FM certified for hazardous areas
- InPro 4881 i electrode is made with a rugged titanium shaft, providing exceptional chemical resistance and durability.



InPro Sensor Designation

The last digit of the InPro designation indicates the pH glass type:

- 00 – High alkali glass (HA)
- 01 – Low temperature glass (LoT)
- 02 – Hydrofluoric acid resistant glass (HF)
- 03 – Steam sterilizable glass (A41)



Quick Tip

A combination pH electrode should never be stored dry as this will dehydrate the electrode. Also, do not store an electrode in deionized water, rather, soak the electrode in the pH buffer or electrolyte recommended in the electrode manual.



Did You Know

The InPro 4801 (i) SG electrode features a unique flat glass membrane ideal for applications with high fiber or solid concentrations.

Suitable Housings

	p.
InFit 761 e	112
InFit 762 e	118
InFlow	122
InDip	120
InTrac 777 e	127
InTrac 781	129
InTrac 785/787	130

InPro 4850 i

For the Toughest Chlor-Alkali Processes



InPro 4850i is a combination pH electrode featuring a sodium membrane glass that uses the sodium concentration in the process (brine) as a reference. The difference in electrical potential between the pH-glass and the sodium reference glass is converted into the pH value. The sodium reference system is highly resistant to chlorine and other oxidizing agents. This makes the sensor very well suited for the demanding process conditions in chlor-alkali production. Solution ground and shielding eliminate interference, and enable redox measurement. Digital signal conversion ensures 100% signal integrity and stability. Intelligent Sensor Management (ISM) technology simplifies sensor handling and reduces sensor lifecycle costs.

Specifications

pH range	0 – 14 pH
Temperature	– 10 to 120 °C (14 to 248 °F)
Operating pressure	0 to 12 barg @120 °C (0 to 174 psig @ 248 °F)
Cable connection	ISM: K8S
Process connection	Pg 13.5 thread
Reference system	Sodium sensitive glass membrane
Type of junction	None
Lengths	120 mm, 225 mm
Shaft diameter	12 mm
Temperature sensor	Digital
Sterilizable	No
Autoclavable	No
pH membrane	High alkali glass (HA)
Min. Na+ concentration	10 mg/L when pH > 7; 100 mg/L when 7 > pH > 2; 1 g/L when pH < 2
Storage solution	Storage solution buffer pH= 4.01/Na 3.9 M (P/N 52 004 103)

Certificates and Approvals METTLER TOLEDO Quality Certificate, Pressure Equipment Directive guidelines (PED) 97/23/EC ATEX: Ex ia IIC T6/T5/T4/T3 Ga/Gb, FM: IS Cl. I, II, III, Div 1, GR ABCDEFG/T6

Intelligent Sensor Management (ISM)

pH electrodes with integrated ISM functionality allow Plug and Measure and advanced diagnostics. ISM simplifies the installation, handling and maintenance of measurement equipment. For more information see ISM introduction pages 10–11.

InPro 4850i requires a near stable sodium concentration for the best measurement results. A 10% difference in brine concentration leads to 0.05 pH error.

Features Overview

- Hermetically sealed reference system resistant to any effects from poisoning substances such as chlorine.
- Very high resistance to oxidizing media, solvents, and acid or alkali solutions.
- Reliable operation in processes with particularly high pressures and high temperatures.
- Platinum solution ground (SG) electrode enables redox (ORP) measurement and advanced sensor diagnostics, as well as preventing measurement errors due to ground potentials.

▶ www.mt.com/InPro4850

Ordering Information

pH Electrodes	Length	Order Number
InPro 4850i/SG	120mm	30 536 625
InPro 4850i/SG	225mm	30 536 627

pH Buffers	Order Number	Order Number
Designation	1 × 250 ml	6 × 250 ml
pH 2.00, 3.9M NaCl	52 004 100	52 004 101
pH 4.01, 3.9M NaCl	52 004 103	52 004 104
pH 7.00, 3.9M NaCl	52 004 106	52 004 107
pH 9.21, 3.9M NaCl	52 004 109	52 004 110

Redox Buffers	Order Number	Order Number
Designation	1 × 250 ml	6 × 250 ml
Redox buffer 320mV, 3.9M NaCl	30 104 917	–

AK9 Coax Cables (–25 °C to 70 °C/–13 to 158 °F)

Designation	Connector	Cable Length	Order Number
AK9	open	1 m (3.3ft)	59 902 167
AK9	open	3 m (9.8ft)	59 902 193
AK9	open	5 m (16.4ft)	59 902 213
AK9	open	10m (32.8ft)	59 902 230
AK9	open	20m (65.6ft)	52 300 204

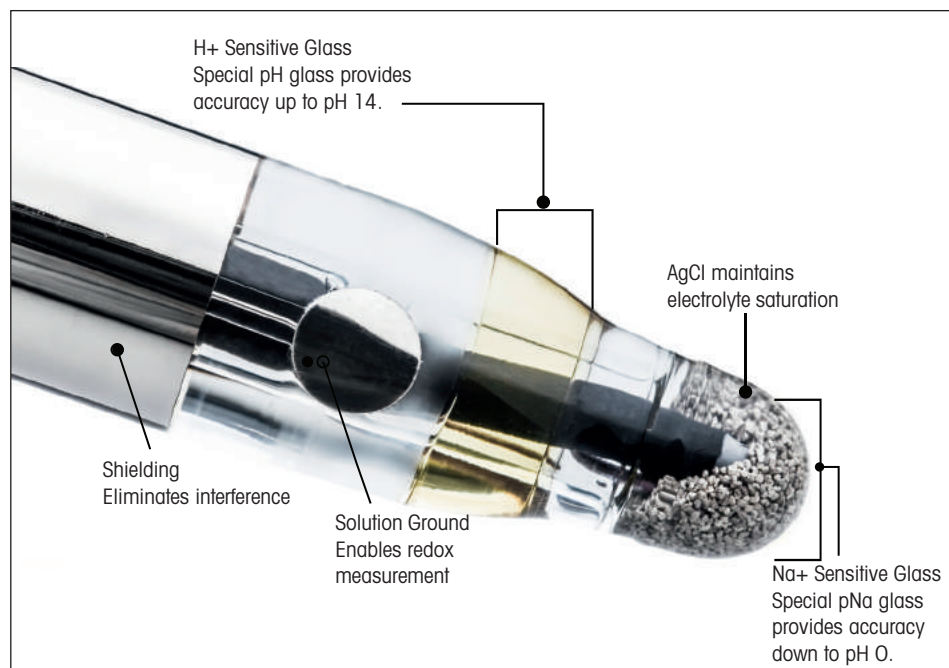

Did You Know
 InPro 4850i is the unique dual-membrane pH sensor with ISM digital signal for resisting chlorine and other oxidizing solutions.

Suitable Housings	p.
InFit 761 e.....	112
InFit 762 e/763e.....	118
InFlow 751	122
InTrac 787	130



Puncture pH Electrodes For Cheese and Meat Products



Puncture pH electrodes are specially designed for quick, accurate pH measurement in meat, sausage, cheese, and fruit. The rugged needle-shaped sensing membrane penetrates directly into the medium, without requiring time-consuming sample preparation. The solid polymer reference system eliminates clogging by fats and proteins using an open junction design. The non-refillable reference electrolyte reduces maintenance to a minimum.

Specifications

pH range	2 – 11 pH
Temperature	0 to 80 °C (32 to 176 °F)
Response time	< 20 s (98 % between pH 4 to 7)
Materials of construction	Glass/PBT (shaft)
Membrane resistance	< 250 MΩ (25 °C/77 °F)
Type of membrane glass	LoT
Temperature sensor	None
Diaphragm	One open aperture junction
Reference system	Argenthal system
Reference electrolyte	Xerolyt Extra solid polymer
Cable and connections	S7-type
Shaft dimensions	Length: 25 mm Diameter: 6 mm
Sterilizable	No
Autoclavable	No
Certificates and Approvals	METTLER TOLEDO Quality Certificate

Features Overview

- Specially designed for direct pH measurement in cheese and meat
- Plastic shaft is FDA listed PBT
- Open aperture junction resists fouling
- Solid polymer electrolyte requires no refilling, reduces maintenance
- Optional puncture knife available for particularly hard cheeses and meats
- Can be used with Pro2Go



Did You Know

The pH measurement in cheese, meat, and fruit provides valuable information on product freshness and quality.

Ordering Information

Product Description	Order Number
Puncture electrode, polymer electrolyte	59 903 311
Puncture knife	59 900 386
Puncture electrode with knife	59 900 388
Cable, 1 m (3.3 ft), BNC connector	59 902 246
Cable, 1 m (3.3 ft), stripped ends	59 902 245
Buffer pouch, pH 4.01, pkt. of 30	51 302 069
Buffer pouch, pH 7.00, pkt. of 30	51 302 047
Buffer pouch, pH 9.21, pkt. of 30	51 302 070

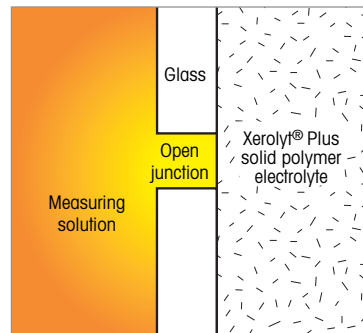

Open reference junction

pH Buffers, Electrolytes, Cleaning and Storage Solutions

Optimal Solutions for Your Process Analytics System



METTLER TOLEDO offers a wide selection of accessories to facilitate ease of use and maintenance of high accuracy pH measurement systems. These include buffers for pH calibration, electrolyte solutions for reference electrodes, and pH sensor simulators for evaluating measurement loops. Below is a partial listing of product accessories available for pH and redox systems.

Ordering Information

pH and Redox Buffers	Volume	Order Number
pH buffers		
pH 4.01 buffer	250ml	51 340 057
pH 7.00 buffer	250ml	51 340 059
pH 9.21 buffer	250ml	51 300 193
pH 10.00 buffer	250ml	51 340 056
pH 2.00 buffer w/3.9M NaCl	250ml	52 004 100
pH 4.01 buffer w/3.9M NaCl	250ml	52 004 103
pH 7.00 buffer w/3.9M NaCl	250ml	52 004 106
pH 9.21 buffer w/3.9M NaCl	250ml	52 004 109
Redox buffers		
Redox buffer 220mV	6 × 250 ml	51 340 081
Redox buffer 468mV	6 × 30 ml	51 319 058
Redox buffer 320mV, w/3.9M NaCl	1 × 250 ml	30 104 917

Reference Electrolyte Solutions

for Liquid-filled Electrodes	Volume	Order Number
Friscolyt B	250ml	51 340 053
Viscolyt	250ml	51 340 235
3M KCl	250ml	51 340 049

Cleaning/Storage Solutions

	Volume	Order Number
pH electrode cleaner /proteins	250ml	51 340 068
Reactivating solution	6 × 30 ml	51 319 053
Storage solution, 3M KCl	250ml	51 340 049
Ceramic diaphragm cleaner	250ml	51 340 070



Did You Know

The primary cause of pH measurement problems is a dirty ceramic diaphragm. Ingold has a complete line of pH cleaning solutions, as well as buffers and electrolyte to keep your electrode functioning properly.

Pro2Go Portable pH/ORP Meter

Simple, Robust and Mobile



Features Overview

- Supports analog, puncture and ISM sensors
- ISM diagnostics
- Calibration timer alerts when calibration is due
- Rugged housing for industrial use

Other Highlights

- Measures pH, ORP and temperature
- IP67 rated housing
- Weatherproof USB interface for data exchange

For periodic pH or redox measurements, a mobile meter is the ideal choice. Designed for laboratory and industrial applications. The intuitive menu on Pro2Go™ ensures out-of-the-box operation for anyone. The meter's ergonomic design allows one-handed operation for both big and small hands. Its light weight makes measurement easy and convenient, even over lengthy periods of repeated measurement.

Pro2Go is compatible with both analog and digital ISM sensors. Its ISM features include Plug and Measure for error-free setup, and display of sensor diagnostics including DLI, ACT and TTM, so operators know when sensor calibration or replacement will be required.

The Pro2Go includes a datalogger that stores up to 2000 measurement data sets and computer interface for easy collection of data from the field.

Specifications

Measurement parameters	pH, mV and temperature
Sensor type	Analog and ISM sensors
pH measuring range	-2.00 to +20.00 pH
mV range	-2000 to +2000 mV
Temperature input	NTC30K
Temperature measuring range	ATC: -5 to 130 °C (+23 to 266 °F) MTC: -30 to 130 °C (-22 to 266 °F)
Predefined buffer groups	9
Automatic buffer recognition	Yes
Calibration	1-point (offset), 2-point (slope and offset)
Supply voltage batteries	4 × LR6/AA 1.5 V Alkaline or 4 × HR6/AA 1.2 V NiMH rechargeable
Battery life (standby)	200 to 250 hrs
Supply voltage (USB powered)	Connection: Micro-USB Rating: 5 V DC, 100 mA
User interface	Graphic LC Display
Languages	10 (English, German, French, Italian, Spanish, Portuguese, Russian, Chinese, Korean and Japanese)
PC connection	Micro-USB for Data transfer and power
Memory size	2000 datasets (GLP conform)
Dimensions	Height × Width × Depth: 222 × 70 × 35 mm (8.74 × 2.76 × 1.38 inch)
Weight	0.29 kg (0.64 lb)
Material	• Housing: ABS/PC reinforced • Window: Polymethylmethacrylate (PMMA)
Enclosure rating	IP 67
Range of application	For indoor and outdoor use
Approvals	CAN/CSA-C22.2 No. 61010-1-12 UL Std. No. 61010-1 (3rd Edition)

www.mt.com/Pro2Go

Ordering Information

Pro2Go portable pH Meter	Order Number
Pro2Go portable pH Meter including USB cable, sensor cable AK9-BNC/RCA for ISM sensors, rubber holster, wrist strap, CD with documentation and software, Declaration of conformity, Test certificate	30 386 271
Accessories	
Rubber holster	30 487 344
USB cable for PC connection	30 487 345
Power adapter for USB cable (to operate instrument without batteries)	30 487 346
Sensor cable AK9-BNC/RCA for ISM sensors	30 487 466
EasyDirect pH PC software	free download
pH Buffer Solutions	
Buffer pouch pH 4.01 (pkt. of 30)	51 302 069
Buffer pouch pH 7.00 (pkt. of 30)	51 302 047
Buffer pouch pH 9.21 (pkt. of 30)	51 302 070



Data transfer via USB interface.



Did You Know

You can get fast and simple data transfer with EasyDirect pH software via USB interface

Dissolved Oxygen Measurement Systems High Reliability and Wide Application Coverage

Real-time, continuous measurement of dissolved oxygen (DO) is central to the efficiency of many industrial processes. METTLER TOLEDO offers a range of robust DO sensors that utilize a well-established electrochemical measuring principle, plus sensors with the latest optical technology for applications where simplicity of operation is particularly important.

Measurement of dissolved oxygen

Proper oxygen levels are important in many processes in biotechnology, pharmaceutical development, food and beverage, chemical manufacturing, and in water and primary waste treatment. Control of dissolved oxygen helps ensure product quality, reduce costs, and provide maximum product yield.

Optical measurement solutions from METTLER TOLEDO

The heart of the optical sensor is an oxygen-sensitive layer containing immobilized marker molecules. They absorb light from a light emitting diode and are able to release this energy as light at a different wavelength (fluorescence).

The fluorescence depends on the amount of oxygen that is present in the environment of the marker molecules. This effect allows determination of the oxygen concentration in the sample media.

Advantages of optical oxygen technology

The optical oxygen sensors offer a highly accurate oxygen measurement with enhanced signal stability and fast response time. The sensors are fully steam sterilizable, autoclavable and fulfill all industrial requirements for hygienic design and traceability. Since no electrolyte exchange or sensor polarization is needed, sensor main-

tenance is easy and less error-prone. This sensor type takes advantage of ISM technology.

Electrochemical oxygen sensors

The large portfolio of Ingold amperometric sensors fulfill the highest industrial requirements in performance and design to accommodate virtually any application. They are equipped with the unique ISM technology.

ISM®



InPro 6860 i



InPro 6960 i
InPro 6970 i



InPro 6900 i
InPro 6950 i



InPro 6800
12 mm and 25 mm

Application guide for dissolved oxygen sensors

	Amperometric hygienic sensors			Optical hygienic sensors			Non hygienic sensors		Portable systems
	InPro 6800	InPro 6850i	InPro 6900/InPro 6900i	InPro 6860i nA/InPro 6860i mA HART (MODBUS)	InPro 6960i	InPro 6970i	InPro 6050	Optical InTap	
Industrial processes									
Pharmaceutical Industry									
Biotechnological applications	•	•		•					
Chemical Industry	•	•							
Beverage Industry	•	•	•		•	•			•
Wastewater applications							•		

Transmitter selection

Several Ingold transmitters are available to work in conjunction with our amperometric and optical sensors including the multi-parameter transmitter lines M100, M200, M300, M400 and M800.

Housings and socket selection

The widest selection of stationary, retractable and submersion housings is provided to match virtually any process connection. Vessel ports or

sockets are used as entry points for the oxygen sensor. METTLER TOLEDO provides a host of ports including the original Ingold 25 mm port which is recognized as a standard in the biotech and pharmaceutical industries.

Professional service and validation

Sensor service includes rebuilding, cleaning, testing, and recertification of your Ingold sensor, done quickly and efficiently to minimize downtime.

Validation and testing of oxygen equipment is done with equipment traceable to NIST.

Integration flexibility

Optical sensors can be integrated directly using their analog (mA-HART) or digital (MODBUS) interface.

InPro 6860 i Optical Oxygen Sensor

Easy Handling, Exceptional Performance

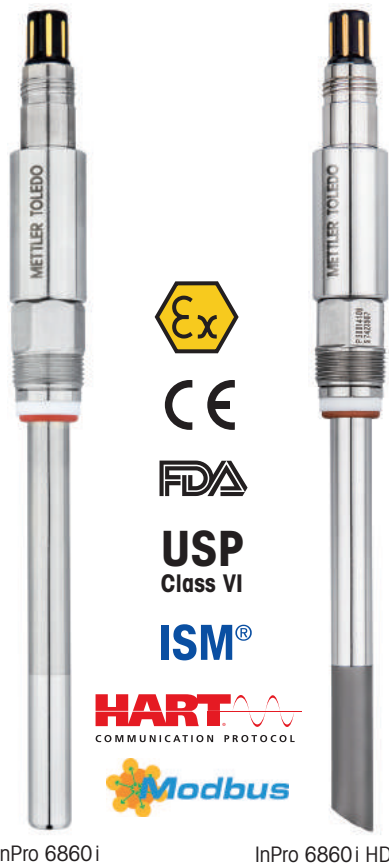

InPro 6860 i

InPro 6860 i HD

Features Overview

- Plug and Measure
- Outstandingly fast service
- Immediate availability without need of polarization
- No electrolyte handling
- Low detection limit
- Highest signal stability
- Fast response time
- All wetted parts in accordance to FDA and USP Class VI-standards
- Sterilizable and autoclavable
- Hygienically polished surface
- Digital ISM technology

Combining innovative ISM technology with high-end optical measurement, METTLER TOLEDO offers optical oxygen sensors fully suitable for biopharma applications. The InPro 6860 i offers highly accurate oxygen measurement with enhanced stability, and easy handling without electrolyte change or time-consuming polarization procedures. The sensor is equipped with a digital interface (digital ISM and Modbus RTU) plus analog output signal for direct integration into existing biocontrollers, analog transmitters and into process environments including HART communication protocol.

Integrates ISM technology

With ISM, the installation, maintenance, and safety of the system is drastically improved. All sensor relevant data are stored in the sensor. Pre-calibrated systems transfer the data automatically to the transmitter and are therefore ready for measuring within seconds. Changes in the measuring system are monitored via the Dynamic Lifetime Indicator. With these features, error-free and safe operation of the sensor and the transmitter is assured. For more information see ISM introduction pages 10–11.

Specifications

Performance

Operating range	0 ppb to saturation (3 bar)
Accuracy	$\leq \pm [1\% + 8 \text{ ppb}]$
Response time at 25 °C (77 °F) (Air → N ₂)	98% of final value in <90s

Construction

Measuring principle	Fluorescence quenching
Cable connection	VP8
Connector design	Straight
Process connection	Pg 13.5
Sensor body	316L stainless steel
OptoCap membrane material	PTFE
Surface roughness of wetted parts	N5/R _a 16 (R _a =0.4 μm/ 16 μin)
O-ring material	EPDM (FDA positive listed)
Sensor diameter	12 mm

Working Conditions

Temperature compensation	Automatic
Measuring temperature range	5 to 60 °C (41 to 140 °F)
Environmental temperature range	InPro 6860 i: –20 to 140 °C (–4 to 284 °F) (sterilizable, autoclavable)

Operating pressure	0.2 to 6 bar (2.9 to 87 psi absolute)
Design pressure	Maximum 6 bar (87 psi absolute)

Certificates and Approvals

METTLER TOLEDO Quality Certificate
 FDA/USP Class VI, 3.1, N5/R_a16
 ATEX

Ordering Information

Sensor	Length	nA	mA; HART	Modbus	OptoCap BT02T	OptoCap BT02THD	Order Number
InPro 6860i nA	120 mm	•		•	•		30 014 100
InPro 6860i nA	220 mm	•		•	•		30 014 101
InPro 6860i nA	320 mm	•		•	•		30 014 102
InPro 6860i nA	420 mm	•		•	•		30 014 103
InPro 6860i nA HD	120 mm	•		•		•	30 449 703
InPro 6860i nA HD	220 mm	•		•		•	30 449 704
InPro 6860i nA HD	320 mm	•		•		•	30 526 901
InPro 6860i nA HD	420 mm	•		•		•	30 526 902
InPro 6860i nA HD	590 mm	•		•		•	30 526 903
InPro 6860i mA	120 mm		•	•	•		30 129 734
InPro 6860i mA	220 mm		•	•	•		30 129 735
InPro 6860i mA	320 mm		•	•	•		30 129 736
InPro 6860i mA	420 mm		•	•	•		30 129 737
InPro 6860i mA HD	120 mm		•	•		•	30 449 705
InPro 6860i mA HD	220 mm		•	•		•	30 449 706
InPro 6860i mA HD	320 mm		•	•		•	30 526 900
InPro 6860i mA HD	420 mm		•	•		•	30 532 157

Transmitter	Order Number
M400 Type 2	30 374 112
M400 Type 3	30 374 113
M400/2H	30 025 514
M400/2(X)H	30 025 515
M400 FF	30 026 616
M400 FF 4-wire	30 374 121
M400 PA	30 026 617
M800 Process, 1-channel	30 026 633
M800 Process, 2-channel	52 121 813
M800 Process, 4-channel	52 121 853
M800 Process, 1-channel SST	30 246 551
M800 Process, 2-channel SST	30 246 552
M800 Process, 4-channel SST	30 246 553
M800 Ethernet/IP Process, 1-channel	30 530 023
M800 Ethernet/IP Process, 2-channel	30 530 024

InPro 6860i Consumables	Order Number
OptoCap BT02T (InPro 6860i)	30 018 857
OptoCap BT02THD	30 302 172

Accessories	Order Number
iLink Multi (incl. automated humidity and pressure compensation)	30 130 631
iLink Multi Cable/Set oDO (Cable set for all oDO sensors)	30 355 582
Power supply in case of need for analog installation of InPro 6860i	30 014 119

OptoCap replacement



OptoCap – BT02T electropolished, delivers a hygienically polished surface.

OptoCap – BT02THD stabilizes the measurement signal by its hydrophilic surface by avoiding air bubble interference.



Did You Know

The optical oxygen sensors can be used in conjunction with all M400 and M800 transmitters as well as with existing analog and digital MODBUS installations.



Did You Know

Oxygen bubble interference can be a common issue when optical oxygen sensors are installed vertically. The new OptoCap™ (BT02THD) with its proprietary design has a surface treatment that efficiently reduces these interferences. This allows greater production control leading to consistent yield, batch to batch.

Suitable Housings

	p.
InFit 761 e.....	112
InTrac 777 e.....	127
InTrac 797 e.....	128
InTrac 781	129
InTrac 785	130

Powering Accessories for InPro 6860 i Digital Sensor Integration

Combined oDO & pH Junction Box with Bluetooth connectivity



InPro 6860 i
Adapter T82



InPro 6860 i
Adapter VP6

Features Overview

- Uses existing cables to biocontrollers
- Simplified installation
- Flexible powering options

The J-Box BTLE simplifies biocontroller upgrades to advanced InPro 6860 i optical oxygen and digital ISM pH sensors without complicated wiring or grounding requirements. Using a shared power supply, the J-Box BTLE connects both oxygen and pH sensors to biocontrollers using existing and standard T-82 (for oxygen) and AK9 (for pH) cables. Measurement signals are sent from the J-Box as nA for oxygen and mV for pH providing universal connectivity to biocontrollers. Standard 1 or 3 meter cables are available for connection from the J-Box BTLE to the oxygen and pH sensors.

The J-Box BTLE is equipped with a Bluetooth interface. It connects to iSense and iSense Mobile for calibration, maintenance and diagnostic purposes.

The InPro 6860 i Adapter provides functionality with a direct connection to InPro 6860 i optical oxygen sensors. 24 V DC is provided through a standard 2.1 mm × 5.5 mm female barrel connection with existing T-82 cables connected to the adapter's outlet.

Flexible installation choices

The J-Box BTLE is ideal for installing ISM optical oxygen and pH sensors onto the head plate of a reactor when space is limited.

The InPro 6860 i Powered Adapter is ideal for installations with sufficient space on the head plate of a reactor and where only optical oxygen is required.

Specifications

Performance

Minimum input power requirement	24 V DC (min. 800 mW, 0.03 A)
Power connection	2.5 mm × 5.5 mm male barrel mating to a 2.1 mm × 5.5 mm female barrel connection

Combined J-Box Sensor Connections

To InPro 6860 i sensor	Male VarioPin
To ISM pH sensor	Male BNC
Simulated O ₂ (nA) to biocontroller	Male T-82 connector* wired for temperature
Simulated pH (mV) to biocontroller	Male K9/K8S

InPro 6860 i Adapter Connections

To InPro 6860 i sensor	Female VarioPin
To biocontroller	Male T-82 connector wired for temperature

* The T-82 Adapter is also available with a VP6 connector.

Details



Ordering Information

Product Description	Order Number
J-Box BTLE	30 365 368
InPro 6860i T-82 Adapter for Biocontroller Retrofit	30 083 984
InPro 6860i VP6 Adapter for Biocontroller Retrofit	30 083 985
Power supply 24 V 0.75 A angled plug	30 323 961

O₂ Accessory Cables (for J-Box BTLE to InPro 6860i sensor)

Product Description	Order Number
Cable, VP-8, 1 m, Female VP	30 094 370
Cable, VP-8, 3 m, Female VP	30 094 371

ISM pH Accessory Cables (for J-Box BTLE to ISM pH sensor)

Product Description	Order Number
Cable, AK9, 1 m, Female BNC	59 902 168
Cable, AK9, 3 m, Female BNC	59 902 194

Biocontroller Retrofit Cables for InPro 6860 i

VP6 (analog)	Order Number	VP8 (digital)	Order Number
All standard VP6 (analog)	see table, pp. 142/143	VP8-ST, 1 m (3.3 ft)	52 300 353
VP6 Connector BNC, 1 m (3.3 ft)	30 032 730	VP8-ST, 3 m (9.9 ft)	52 300 354
VP6 Connector BNC, 3 m (9.9 ft)	30 032 731	VP8-ST, 5 m (16.4 ft)	52 300 355
VP6 Connector LEMO, 1 m (3.3 ft)	30 032 732	VP8-ST, 10 m (32.8 ft)	52 300 356
VP6 Connector LEMO, 3 m (9.9 ft)	30 032 733	VP8-ST, 15 m (49.2 ft)	52 300 357
VP6 Connector Lumberg, 1 m (3.3 ft)	30 032 734	VP8-ST, 20 m (65.6 ft)	52 300 358
VP6 Connector Lumberg, 3 m (9.9 ft)	30 032 735	VP8-ST, 35 m (114.8 ft)	52 300 359



Did You Know

The J-Box BTLE is an ideal solution to retrofit biocontrollers with InPro 6860i and ISM pH sensors. The integral 2.5 mm × 5.5 mm barrel connector enables simplified power connection. METTLER TOLEDO recommends using a three-pronged grounded 24 V DC power supply for best performance.



Additional Cable Options

METTLER TOLEDO offers a wide variety of oxygen and pH cables for connecting the J-Box BTLE or InPro 6860i Adapter to your biocontrollers. Please contact your local representative to learn more about our available options.

InPro 6960 i/InPro 6970 i Optical Oxygen Sensor

Reliable and Intelligent



Features Overview

- Plug and Measure
- Fast maintenance in less than 1 minute
- Immediate availability, no need for polarization
- No electrolyte handling
- Low detection limit
- Highest signal stability
- Fast response time
- All wetted parts in accordance to FDA and USP Class VI-standards
- Fully CIP and SIP resistant
- Hygienically polished surface finish of N5/R_a16 (R_a=0.4 μm/16 μin)
- Digital ISM technology

Optical technology in 12 mm design is available for challenging brewery applications such as filler line measurement. These optical sensors offer high performance together with reduced and easier maintenance. The outstanding measurement performance with low detection limit, minimum drift and short response time improves oxygen monitoring and helps to reduce out of spec production. The easy maintenance without liquid handling and polarization increases the availability of the measuring system.

ISM

ISM technology helps to make optical oxygen measurement simple and more reliable. Thanks to the Dynamic Lifetime Indicator (DLI) and Adaptive Calibration Timer (ACT), maintenance planning becomes easy and the risk of sensor failures during production time is significantly reduced. For more information see ISM introduction pages 10–11.

Specifications

Performance

Operating range	InPro 6960 i: 0 ppb to 25 ppm InPro 6970 i: 0 ppb to 2000 ppb
-----------------	--

Accuracy	InPro 6960 i: $\leq \pm [1 \% + 8 \text{ ppb}]$ InPro 6970 i: $\leq \pm [1 \% + 2 \text{ ppb}]$
----------	--

Response time at 25 °C (77 °F) (Air → N ₂)	98 % of final value in <20 s
--	------------------------------

Residual signal in oxygen-free medium	<0.025 % of the signal in ambient air
---------------------------------------	---------------------------------------

Construction

Measuring principle	Fluorescence quenching
---------------------	------------------------

Cable connection	5-Pin
------------------	-------

Connector design	Straight
------------------	----------

Process connection	Pg 13.5
--------------------	---------

Sensor body	316L stainless steel
-------------	----------------------

Membrane material	Silicone
-------------------	----------

Surface roughness of wetted parts	N5/R _a 16 (R _a =0.4 μm/16 μin)
-----------------------------------	--

O-ring material	EPDM (FDA positive listed)
-----------------	----------------------------

Sensor diameter	12 mm
-----------------	-------

Working Conditions

Temperature compensation	Automatic
--------------------------	-----------

Measuring temperature range	–5 to 40 °C (23 to 104 °F)
-----------------------------	----------------------------

Environmental temperature range	0 to 121 °C (32 to 250 °F) (sterilizable)
---------------------------------	---

Operating pressure	0.2 to 12 bar (2.9 to 174 psi absolute)
--------------------	---

Design pressure	Maximum 12 bar (174 psi absolute)
-----------------	-----------------------------------

Certificates and Approvals

METTLER TOLEDO Quality Certificate,
FDA/USP Class VI, 3.1, N5/R_a16

► www.mt.com/InPro6960i

► www.mt.com/InPro6970i

Ordering Information**12 mm InPro 6960 i/6970 i**

Sensor	Length	Order Number
InPro 6960 i	120 mm	52 206 500
InPro 6960 i	220 mm	52 206 501
InPro 6960 i	320 mm	52 206 502
InPro 6970 i	120 mm	52 206 393
InPro 6970 i	220 mm	52 206 394
InPro 6970 i	320 mm	52 206 395

Transmitter

M400 Type 3	30 374 113
M400/2H	30 025 514
M400/2(X)H	30 025 515
M400 FF	30 026 616
M400 PA	30 026 617
M800 SST, 1-channel	30 246 551
M800 SST, 2-channel	30 246 552
M800 Process, 1-channel	30 026 633
M800 Process, 2-channel	52 121 813
M800 Process, 4-channel	52 121 853

InPro 6960 i/6970 i Consumables

OptoCap BW01 for 6960 i	52 206 509
OptoCap BR01 for 6970 i	52 206 403
O-ring set	52 206 252

Sensor Cables

2 m (6.6 ft)	52 300 379
5 m (16.4 ft)	52 300 380
10 m (32.8 ft)	52 300 381
15 m (49.2 ft)	52 206 422

Accessories

iLink-RS485 Sensor Cable for iSense	52 300 399
iLink Multi	30 130 631
iLink Multi cable set oDO	30 355 582
Housing retrofit kit	52 403 811
Maintenance cap	52 206 251

Did You Know

In conjunction with the M400, the **InPro 6960 i** offers an easy-to-use solution for high ppm measurements as found in wort aeration monitoring.

Other Highlights

- No electrolyte necessary
- No polarization required
- Easy maintenance

Did You Know

In conjunction with the M400, the **InPro 6970 i** offers an easy-to-use solution for low ppb measurements throughout brewing and filler lines.

OptoCap replacement

One piece O-ring-free OptoCap

Suitable Housings

InFit 761 e.....	112
InTrac 777 e.....	127
InTrac 797 e.....	128

InPro 6800/InPro 6850 i (12 & 25 mm) For Accurate Oxygen Measurement



InPro 6850 i InPro 6800

Features Overview

- Revolutionary “Quick Disconnect” system allows for service in seconds
- Defection limit down to 6 ppb
- Accurate measurement and quick response
- Long lasting and easy to maintain membranes
- FDA positive listed materials of construction
- Hygienically polished surface finish of N5/R_a16 (R_a=0.4 μm/16 μin)
- EHEDG certified for cleanability and 3A compliant
- Wetted O-rings comply with FDA and USP Class VI standards
- Autoclavable and steam sterilizable

The InPro 6800 dissolved oxygen sensor with 12 or 25 mm diameter body provides maximum accuracy and ultimate cleanability for vessels with limited space or in containers with smaller volumes. The sensor is available with the state-of-the-art VP connector or T-82 connector in straight or angled versions. A durable 316L stainless steel construction allows for CIP, steam sterilization or autoclaving in place, and the high sensor finish virtually eliminates contamination of the process. Ingold’s PTFE/silicone membranes have been designed with an internal steel mesh that makes the membrane more rugged and dramatically increases membrane life.

Specifications

Performance

Operating range	0 ppb to saturation (5 bar)
Accuracy	≤ ± [1 % +6 ppb]
Response time at 25 °C (77 °F)	98 % of final value in < 90 s
Sensor signal in air at 25 °C (77 °F)	50 to 110 nA
Residual signal in oxygen-free medium	< 0.1 % of the signal in ambient air

Construction

Measuring principle	Amperometric Clark electrode
Cable connection	Analog VarioPin (IP68), Digital K8S (IP68)
Connector design	Straight or angled
Process connection	Pg 13.5 (12 mm); Ingold (25 mm)
Sensor body	316L stainless steel
Membrane material	PTFE/Silicone/PTFE (reinforced with steel mesh)
Surface roughness of wetted parts	N5/R _a 16 (R _a =0.4 μm/16 μin)
O-ring material	Silicone (FDA and USP Class VI positive listed)
Sensor diameter	12 mm/25 mm

Working Conditions

Temperature compensation	Automatic
Measuring temperature range	0 to 80 °C (32 to 176 °F)
Environmental temperature range	–5 to 140 °C (23 to 284 °F) (steriliz., autocl.)
Operating pressure	0.2 to 6 bar (2.9 to 87 psi absolute)
Design pressure	Maximum 12 bar (174 psi absolute)

Certificates and Approvals

	METTLER TOLEDO Quality Certificate, EHEDG, FDA/USP Class VI, 3.1, N5/R _a 16,
ATEX:	Ex ia IIC T6/T5/T4/T3 Ga/Gb, Ex ia IIIC T69 °C/T81 °C/T109 °C/T161 °C Da/Db
FM:	IS Cl. I, II, III, Div 1, GR ABCDEFG/T6

Intelligent Sensor Management (ISM)

InPro 6850i sensors with integrated ISM functionality allow Plug and Measure and advanced diagnostics. ISM simplifies the installation, handling and maintenance of measurement equipment. For more information see ISM introduction pages 10–11.

Other Highlights

- Small 12 or 25 mm diameter saves valuable space
- Pg 13.5 threads for interface into housings
- Comes with either watertight VP connector (IP68) or T-82 connector
- Ingold 25 mm sensor design recognized as a standard in the industry
- Cap nut allows for easy interface to Ingold ports

► www.mt.com/InPro6800

Ordering Information

12 mm InPro 6800/6850 i DO Sensor Series

Sensor	Length	Connector	VP Number	ISM Number
InPro 6800/6850 i	70 mm	Straight	52 200 964	52 206 118
InPro 6800/6850 i	120 mm	Straight	52 200 965	52 206 119
InPro 6800/6850 i	220 mm	Straight	52 200 966	52 206 120
InPro 6800/6850 i	320 mm	Straight	52 200 967	52 206 121
InPro 6800/6850 i	420 mm	Straight	52 200 968	52 206 122
InPro 6810	70 mm	Angled	52 200 969	
InPro 6810	120 mm	Angled	52 200 970	
InPro 6810	220 mm	Angled	52 200 971	
InPro 6810	420 mm	Angled	52 200 973	

12 mm InPro 6800 DO Sensor Series (T-82 Connector)

Sensor	Length	Connector	Order Number
InPro 6820	120 mm	Straight T-82	52 201 012
InPro 6820	220 mm	Straight T-82	52 201 013
InPro 6820	320 mm	Straight T-82	52 201 014
InPro 6820	420 mm	Straight T-82	52 201 015
InPro 6830	120 mm	Angled T-82	52 201 016
InPro 6830	220 mm	Angled T-82	52 201 017
InPro 6830	320 mm	Angled T-82	52 201 018
InPro 6830	420 mm	Angled T-82	52 201 019

25 mm InPro 6800/6850 i DO Sensor Series

Sensor	Length	Connector	VP Number	ISM Number
InPro 6800/6850 i	80 mm	Straight	52 200 974	52 206 123
InPro 6800/6850 i	160 mm	Straight	52 200 975	52 206 124
InPro 6800/6850 i	260 mm	Straight	52 200 976	52 206 125
InPro 6800/6850 i	360 mm	Straight	52 200 977	52 206 126
InPro 6810	80 mm	Angled	52 200 978	
InPro 6810	100 mm	Angled	52 200 982	
for B. Braun ports	EPDM O-rings			
InPro 6810	160 mm	Angled	52 200 979	
InPro 6810	260 mm	Angled	52 200 980	
InPro 6810	360 mm	Angled	52 200 981	

For available sensors for B. Braun ports please ask your local sales organization.

25 mm InPro 6800 DO Sensor Series (T-82 Connector)

Sensor	Length	Connector	Order Number
InPro 6820	80 mm	Straight T-82	52 201 020
InPro 6820	160 mm	Straight T-82	52 201 021
InPro 6820	260 mm	Straight T-82	52 201 022
InPro 6830	80 mm	Angled T-82	52 201 023
InPro 6830	160 mm	Angled T-82	52 201 024
InPro 6830	260 mm	Angled T-82	52 201 025

InPro 6800/6850 i Consumables

	Order Number
Membrane body, single T-96	52 200 071
Membrane kit T-96 (4 membranes, 1 O-ring set silicone, 25 ml of electrolyte, wetted parts SS 316L)	52 200 024
Membrane bodies (16 pieces), T-96	52 206 114
O ₂ electrolyte pack (3 × 25 mL)	30 298 424
InPro 6800 replacement anode/cathode assembly	52 200 899
InPro 6850 i replacement anode/cathode assembly	52 206 347

For accessories, cables and cable lengths refer to page 142–149.

InPro 6800 sensor master with sensor

Angled version of InPro 6800



Replaceable anode/cathode assembly



Did You Know

The dissolved oxygen membrane used on these sensors is more durable and less prone to fouling than competitive products due to its advanced membrane design. This makes these sensors an excellent choice for dirty DO applications.

Suitable Housings for 12 mm p.

InFit 761 e.....	112
InFit 762 e/763 e.....	118
InFlow	122
InDip	120
InTrac 777 e.....	127
InTrac 797 e.....	128
InTrac 781	129
InTrac 785/787	130

InPro 6900 (i)/InPro 6950 i Accurate Trace Oxygen Measurement



InPro 6950 i InPro 6900

Angled version also available

USP
Class VI



ISM[®]

Features Overview

- Revolutionary “Quick Disconnect” system allows for service in seconds
- Accurate measurement at very low levels of oxygen
- Long lasting and easy to maintain membranes
- FDA positive listed materials of construction
- Hygienically polished surface finish of N5/R_a16 (R_a=0.4 μm / 16 μin)
- EHEDG certified for cleanability and 3-A compliant
- Wetted O-rings comply with FDA and USP Class VI standards
- Steam sterilizable

▶ www.mt.com/InPro6950

▶ www.mt.com/InPro6900

The InPro 6900 and the InPro 6950 dissolved oxygen sensors with 12 mm diameter body offer the same advanced features as the InPro 6800, with the additional benefit of being able to measure trace oxygen concentrations. In particular, the InPro 6950 i sensor offers excellent accuracy at the lowest oxygen levels due to the built-in 4-electrode measurement system. Ingold’s unique cathode design, membrane and specially formulated electrolyte generate stable and accurate results at extremely low levels of oxygen.

Specifications

Performance

Operating range	InPro 6900 (i): 1 ppb to saturation in aqueous solutions 3 ppb to saturation in CO ₂ containing solutions
	InPro 6950 i: 0.1 ppb to saturation in aqueous solutions 0.25 ppb to saturation in CO ₂ containing solutions

Accuracy	InPro 6900 (i): ≤ ± [1 % + 1 ppb] / ≤ ± [1 % + 3 ppb]
	InPro 6950 i: ≤ ± [1 % + 0.1 ppb] / ≤ ± [1 % + 0.25 ppb]

Response time at 25 °C (77 °F)	InPro 6900 (i): 98 % of final value in <90 s
	InPro 6950 i: 90 % of final value in <90 s

Sensor signal in air at 25 °C (77 °F)	InPro 6900 (i): 250 to 500 nA
	InPro 6950 i: 2500 to 6000 nA

Residual signal in oxygen-free medium	InPro 6900 (i): <0.03 % of the signal in ambient air
	InPro 6950 i: <0.025 % of the signal in ambient air

Construction

Measuring principle	Amperometric Clark electrode
Sensor design	12 mm sensor with VP design
Connector design	Straight or angled
Process connection	Pg 13.5
Sensor body	316L stainless steel
Membrane material	PTFE/Silicone (reinforced)
Surface roughness of wetted parts	N5/R _a 16 (R _a =0.4 μm / 16 μin)
O-ring material	Silicone (FDA and USP Class VI positive listed)

Working Conditions

Temperature compensation	Automatic
Measuring temperature range	0 to 80 °C (32 to 176 °F)
Environmental temperature range	InPro 6900 (i): –5 to 140 °C (23 to 284 °F) (sterilizable and autoclavable)
	InPro 6950 i: –5 to 121 °C (23 to 250 °F) (sterilizable)
Operating pressure	InPro 6900 (i): 0.2 to 6 bar (2.9 to 87 psi absolute) 0.2 to 9 bar (2.9 to 130 psi absolute) with T-6900 R
	InPro 6950 i: 0.2 to 9 bar (2.9 to 130 psi absolute)
Design pressure	Maximum 12 bar (174 psi absolute)

Certificates and Approvals

METTLER TOLEDO Quality Certificate, EHEDG, FDA/USP Class VI, 3.1, N5/Ra16, ATEX: Ex ia IIC T6/T5/T4/T3 Ga/Gb, Ex ia IIIC T69 °C/T81 °C/T109 °C/T161 °C Da/Db FM: IS Cl. I, II, III, Div 1, GR ABCDEFG/T6

Intelligent Sensor Management (ISM)

Intelligent Sensor Management (ISM) InPro 6900 i and 6950 i sensors with integrated ISM functionality allow Plug and Measure and advanced diagnostics. ISM simplifies the installation, handling and maintenance of measurement equipment. For more information see ISM introduction pages 10–11.



Ordering Information

12 mm InPro 6900 (i) DO Sensor Series

Sensor	Length	Connector Style	VP Order Number	ISM Order Number
InPro 6900 (i)	70 mm	Straight	52 200 944	52 206 316
InPro 6900 (i)	120 mm	Straight	52 200 945	52 206 317
InPro 6900 (i)	220 mm	Straight	52 200 946	52 206 318

12 mm InPro 6950 i DO Sensors

Sensor	Length	Connector Style	ISM Order Number
InPro 6950 i	70 mm	Straight	52 206 127
InPro 6950 i	120 mm	Straight	52 206 128
InPro 6950 i	220 mm	Straight	52 206 129
InPro 6950 i	320 mm	Straight	52 206 130

InPro 6900 (i) Consumables

	Order Number
Membrane body, single InPro 6900 (i)	52 201 049
Membrane kit InPro 6900 (i)	52 201 003
(4 membranes, 1 O-ring set silicone, 10 ml of electrolyte, wetted parts SS 316L)	
Reinforced membrane body, single InPro 6900 (i) (T-6900 R)	52 201 108
Reinforced membrane kit InPro 6900 (i) (T-6900 R)	52 201 109
(4 membranes, 1 O-ring set silicone, 10 ml of electrolyte, wetted parts SS 316L)	
InPro 6900 electrolyte pack (3 × 5 mL)	30 298 425
InPro 6900 (i) replacement anode/cathode assembly	52 200 943

InPro 6950 (i) Consumables

	Order Number
Membrane kit InPro 6950 i	52 206 106
(4 membranes, 1 O-ring set silicone, 10 ml of electrolyte, wetted parts SS 316L)	
InPro 6950 electrolyte pack (3 × 5 mL)	30 298 426
InPro 6950 i replacement anode/cathode assembly	52 206 112

For accessories and spare parts refer to p. 53.

Replaceable anode/cathode assembly for InPro 6950



Reinforced membrane body InPro 6900

Other Highlights

- Small 12 mm diameter saves valuable space
- Watertight VP connector (IP68)
- Variety of sensor lengths available
- Withstands CIP

InPro 6900 (i)/InPro 6950 i Transmitter Compatibility

Sensor	M400 Type 3	M800 2/4-ch	M800 1-ch
InPro 6900	•	–	•
InPro 6900 i	•	•	•
InPro 6950	–	–	•
InPro 6950 i	•	•	•

Suitable Housings

	p.
InFit 761 e.....	112
InFit 762 e/763 e.....	118
InFlow	122
InDip	120
InTrac 777 e.....	127
InTrac 797 e.....	128
InTrac 781	129
InTrac 787	130

InTap: Portable Optical Dissolved Oxygen Analyzer Maximum Control of Beverage Quality



Dissolved oxygen level is an important quality factor in the food and beverage industry. Maintaining low oxygen levels in food and beverage production ensures flavor stability as well as long shelf life. The InTap, with an internal optical DO sensor, allows users to measure dissolved oxygen values wherever and whenever required for optimum control of production processes and product quality.

The InTap is used for the measurement of beverage DO, and at-line measurement of beer during or after filtration and prior to filling. Further, the InTap is the perfect reference measurement instrument for calibrating installed in-line oDO sensors that measure at the lowest oxygen ranges.

The InTap is equipped with a Bluetooth interface and can connect to sensors equipped with the T100 Bluetooth tool.

Reference calibration is done with a few clicks and can be transmitted wirelessly to the sensor. All data is stored in the InTap's USB-connected storage and a database of measurement points is easily built up.

Specifications

Measurement parameters	DO saturation e.g. concentration and temperature
Operating range*	0 ppb to 2000 ppb
Accuracy*	$\leq \pm [1\% + 2 \text{ ppb}]$
Response time at 25°C (air to N ₂); † 98%	< 20s
Temperature measuring range	-5 to 60 °C (23 to 140 °F)
Operating pressure range	0 to 6 bar
Design pressure	10 bar
Protection rating	IP 67
Weight	3.5 kg
Battery	up to 24 h
Data storage	8 GB

*Sensor specifications

Features Overview

- 4.0" touchscreen
- Fast response time
- Lowest calibration requirement
- Highest accuracy down to 2 ppb
- IP 67 enclosure resists harsh environments

Other Highlights

- Full user management
- Wireless in-line sensor calibration
- Data logging up to 24 h
- Measurement point data management
- Calibration report management
- ISM predictive maintenance tools

Ordering Information

Analyzer	Order Number
InTap portable oDO analyzer imp. inch/US	30 457 912
Accessories	Order Number
T100 M12 Bluetooth Interface for in-line sensor	30 432 819
InTap4000 tank connector	52 200 261
Adapter Kit	30 643 551
Replacement Parts	Order Number
InTap 12V Power Supply Set	30 383 009
OptoCap for InTap (OptoCap BR01)	52 206 403
O ₂ sensor InTap	30 422 571
Polyamide hose \varnothing 6×4 mm	30 422 575
Polyamide hose \varnothing 1/4" (2 m)	30 461 774



T100: Bluetooth interface for oDO sensors.



Touchscreen interface with convenient data management

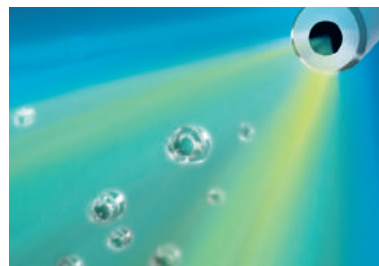

Stable and accurate results with minimized calibrator demands.

Beyond optical technology METTLER TOLEDO has implemented Automatic Stability Control (ASC) to ensure stable and reliable results, also minimizing calibration demands.



With the InTap you can store the calibration data of installed sensors and build up an electronic database for sensor management. Data is stored on a USB stick and can be transferred conveniently to a PC.



Did You Know
Installed oDO sensors can be upgraded with the T100 Bluetooth tool, allowing calibration data to be sent wirelessly to the InTap.

InPro 6050 Continuous Control of Your Wastewater Application



The InPro 6050 dissolved oxygen sensor provides reliable continuous measurement of dissolved oxygen in water applications including biological treatment in wastewater. The InPro 6050 offers proven Ingold sensor technology with an integrated thermistor in a rugged plastic sensor body providing optimum measurement accuracy at an affordable price. The PTFE/silicone membrane is reinforced by an integral stainless steel mesh, which provides durability and mechanical stability to ensure reliable, continuous on-line measurement.

Specifications

Performance

Operating range	30 ppb to saturation
Accuracy	± [1 % + 30 ppb]
Response time at 25 °C (77 °F)	98 % of final value in < 90 s
Sensor signal in air at 25 °C (77 °F)	40 to 110 nA
Residual signal in oxygen-free medium	< 0.3 % of the signal in ambient air

Construction

Measuring principle	Amperometric Clark electrode
Cable connection	VP
Connector design	Straight
Process connection	Pg 13.5
Sensor body	PPS
Membrane material	PTFE/Silicone/PTFE (reinforced w/steel mesh)
O-ring material	Viton®, Silicone
Sensor diameter	12 mm
Shaft length	120 mm

Working Conditions

Temperature compensation	Automatic
Measuring temperature range	0 to 60 °C (32 to 140 °F)
Design pressure	Maximum 2 bar (29 psi absolute)

Certificates and Approvals

METTLER TOLEDO Quality Certificate

Features Overview

- Rugged sensor designed for the wastewater industry
- Low maintenance
- Accurate measurement and quick response
- Long lasting and easy to maintain membranes
- Watertight VP connector (IP 68)
- PTFE coated membrane protects the membrane against particle adhesion and chemical interference

Ordering Information

Sensor	Length	Connector Style	Order Number
InPro 6050	120 mm	Straight VP	52 200 851

InPro 6050 Consumables

Order Number

Membrane body, single T-96	52 200 071
Membrane kit T-96 (4 membranes, 1 O-ring set, 25 ml of electrolyte)	52 200 024
O ₂ electrolyte pack (3 × 25 ml)	30 298 424

For accessories and spare parts refer to p. 53

► www.mt.com/InPro6050

Oxygen Accessories and Spare Parts

For Efficient Operation



Membrane kit with 4 membranes and electrolyte

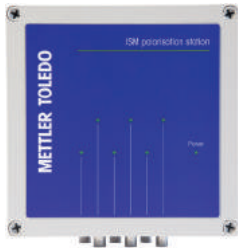

6-port ISM polarization station for digital oxygen sensors



ISM O₂ Verification Kit. See page 106 for details.



ISM Optical O₂ Verification Kit. See page 107 for details.

An oxygen measuring system is made up of several important components and because the measurement is so critical to the process, all of them need to operate efficiently. This section outlines the accessories and maintenance items that can be used to optimize and maintain the quality of measurement.

Membrane maintenance

Perhaps the most common problem seen over time with electrochemical oxygen sensors is membrane integrity. During the course of a membrane's life it may encounter difficult situations such as harsh samples, multiple sterilization cycles, or impact, all of which cause normal wear and tear on the membrane. Ingold pioneered the design of the PTFE and silicone membrane with a built-in steel mesh that greatly increases membrane durability, extends membrane life and can be easily and quickly replaced as required. We offer multiple membrane styles according to your application including those that have FDA positive listed components for wetted parts.

Spare Parts – Ordering Information

InPro 6800 and InPro 6000 Series Sensor Membranes	Order Number
Membrane kit, S-96 (silicone)	52 200 025
Membrane kit, T-96 (PTFE)	52 200 024
Membrane body, single, S-96	52 200 072
Membrane body, single, T-96	52 200 071
O ₂ electrolyte pack (3 × 25 ml)	30 298 424
Cap sleeve N (no protective cage)	52 200 037
Cap sleeve P (protective cage)	52 200 038
Cap sleeve N, HA-C22	52 200 642

Accessories – Ordering Information

Product Description	Order Number
Digital ISM sensor master	52 206 329
Digital ISM sensor 6-port polarization station	52 206 480
ISM simulator O ₂ Kit for InPro 6850i/6850iG	52 300 416
ISM simulator O ₂ ppb Kit for InPro 6900i/6900iG	52 300 422
ISM simulator O ₂ Trace Kit for InPro 6950i/6950iG	52 300 428
InPro 6800 sensor master polarization unit	52 200 892
InPro 6900 sensor master polarization unit	52 200 893
InPro 6950 sensor master polarization unit	52 206 113
DO sensor simulator for T-82 cabled transmitters	59 906 816
DO sensor simulator for VP cabled transmitters	52 200 891
Oxygen zeroing gel (3 × 25 mL)	30 300 435
Adapter T-82 cable to VP electrode connector	52 200 939
Adapter VP cable to T-82 electrode connector	52 200 940
Cap sleeve without protective cage N-type (SS 316L)	52 200 037
Cap sleeve with protective cage P-type (SS 316L)	52 200 038
Cap sleeve without protective cage N-type (C22)	52 200 642
Cap sleeve without protective cage N-type (Ti)	52 200 268
Optical O ₂ Simulator	30 404 694

Introduction

Reliable Monitoring and Control of the CO₂ Level

In Situ Monitoring of Dissolved CO₂ in Bioreactors For Successful Fermentation

The importance of dissolved carbon dioxide in biotech or pharmaceutical processes

Besides pH and dissolved oxygen measurements, reliable monitoring and control of the CO₂ partial pressure is important for successful fermentation. METTLER TOLEDO Ingold's CO₂ system delivers precise, real-time data that increases understanding of critical fermentation and cell culture processes. This information will help you gain insight into cellular metabolism and other changes within the bioreactor.

A significant trend in biotechnology today is the increasing use of mammalian cell lines including human, monkey, mouse and bovine cells. Various types of bioreactors are now being used to cultivate these animal cells. One of the most important requirements for optimal cell growth in a bioreactor is continuous monitoring and control

of critical parameters, which include O₂, pH, CO₂ and temperature. Reliable measurement of CO₂ is essential for successful large-scale operation as the accumulation of CO₂ becomes more problematic at high viable cell concentrations. High CO₂ concentrations can inhibit cell growth and product formation in mammalian cells and alter the glycosylation pattern of recombinant proteins. By maintaining low and constant levels of CO₂, the production rate of pharmaceuticals, proteins and antibodies can be significantly increased.

Dissolved carbon dioxide sensors

The InPro 5000 i dissolved CO₂ sensor utilizes the Severinghaus principle of CO₂ measurement which was developed in 1958 for use in blood-gas analysis. The sensing electrode in this principle is an enhanced pH electrode separated from the measurement media by an electrolyte-filled gas permeable

membrane. CO₂ diffuses through the membrane and into the inner electrolyte where it equilibrates with bicarbonate ions, altering the pH value. The relative change in pH value of the electrolyte is then measured by the enhanced pH electrode and correlated to CO₂.

The InPro 5000 i series sensor has been optimized for in situ analysis of dissolved CO₂ in fermentation and cell culture processes. This sensor has a high surface finish for ultimate cleanability and can be steam sterilized or autoclaved. The modular membrane allows for maintenance in seconds and its unique construction stops interference of volatile acids which are often found in bioprocesses.



A perfect team: M400 transmitter with InPro 5000 i CO₂ sensor

Measuring principle of the InPro 5000 i sensor

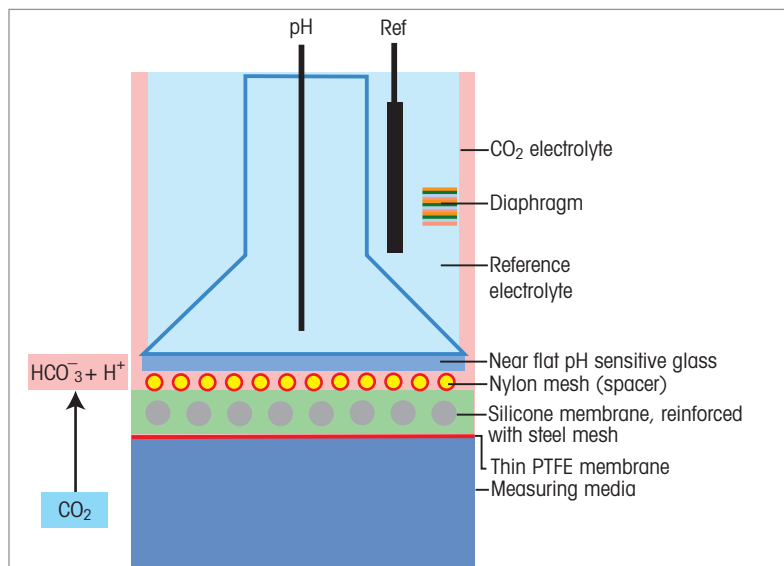

In-line CO₂ Measurement in Beverages

Proven Technology, Simplified Operation

In-line CO₂ measurements in brewery and carbonated soft drinks processes are commonly used to ensure consistent beverage quality. However, initial investment, installation costs, and expenditure caused by unscheduled system downtime can amount to an unfavorable total lifetime cost of measurement equipment. A sensor that offers simplified handling and enhanced diagnostics leads to more reliable and cost effective operation.

Importance of CO₂ measurements

For consumers, the mouthfeel (and foam in the case of beer) is as important as a beverage's taste. Monitoring and controlling dissolved CO₂ concentrations helps ensure consumers experience the sight and effervescence of your products the way you want them to. Consequently, typical applications for in-line CO₂ measurement systems in beverage producing processes are:

- Beverage carbonation control
- Measurements in filling lines
- Monitoring of possible CO₂ losses in critical process steps
- Deaerated water carbonation control

As much as reproducible CO₂ concentrations are responsible for consistent product quality, different packaging solutions also require different CO₂ levels for beverage dispensing and process safety reasons, e.g. to avoid mechanical damage to cans in tunnel pasteurizers due to high CO₂ levels. Table 1 shows typical concentration ranges for different beverages and packages.

Thermal conductivity plus Intelligent Sensor Management

The InPro 5500i combines enhanced TC measurement with the proprietary Intelligent Sensor Management (ISM) concept. ISM simplifies sensor handling, enhances reliability and reduces sensor lifecycle costs. Plug and Measure installation and predictive maintenance tools, such as an indicator for falling membrane integrity, increases measurement point uptime and improve process safety.

Together with the M400 ISM transmitter operators can take full advantage of features that non-ISM systems cannot match.

Product	Typical CO ₂ Concentration
Deaerated water used in blending processes	2 g/L (1 Vol) up to concentration of packaged beverage
Beers filled in cans/kegs	Up to 5.2 g/L (2.6 Vol)
Bottom fermented beers in bottles	5 to 6 g/L (2.5 to 3.0 Vol)
Top fermented beers in bottles	6 to 9 g/L (3 to 4.5 Vol)
Carbonated soft drinks	5 to 10 g/L (2.5 to 5 Vol)

Table 1: Typical CO₂ ranges in carbonated beverages

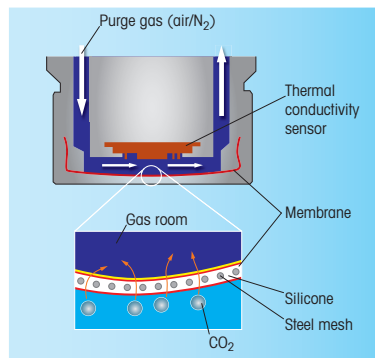

Fig 1: TC sensor design—complete avoidance of moving parts



Fig 2: METTLER TOLEDO's InPro 5500i in-line dissolved CO₂ sensor employs thermal conductivity measurement

InPro 5000 i For Accurate CO₂ Measurement



USP
Class VI



ISM[®]

The InPro 5000 i dissolved carbon dioxide sensor allows for the accurate measurement and control of dissolved CO₂ in biopharmaceutical applications. The measuring principle is based on the Severinghaus principle of potentiometric CO₂ measurement which has been widely accepted for over 55 years. The high surface finish of the stainless steel sensor prevents contamination and the sensor is fully sterilizable either in-situ or in an autoclave. The design of the membrane dramatically reduces full service time to just minutes. The interior body, a high performance pH electrode, can easily be replaced at your site. No need to send the sensor in for service. Also available with Intelligent Sensor Management (ISM) for Plug and Measure and advanced diagnostics (see pages 10-11).

Specifications

Performance	
Measuring range	10 to 1000 mbar pCO ₂
Accuracy	± 10 % (pCO ₂ 10 to 900 mbar) ± 15 % (pCO ₂ > 900 mbar)
Response time	90 % of final value < 120 s at 25 °C (77 °F)
Construction	
Measuring principle	Potentiometric Severinghaus
Cable connection	K8S
Process connection	Pg 13.5
Sensor body	316L stainless steel
Membrane material	Silicone (reinforced with steel mesh)
Surface roughness of wetted parts	N5 (R _a = 0.4 μm / 16 μin)
O-ring material	Viton [®] , Silicone (FDA compliant)
Sensor diameter	12 mm
Working Conditions	
Temperature compensation	Automatic
Temperature sensor	Digital
Measuring temperature range	0 to 60 °C (32 to 140 °F)
Sterilization temperature	135 °C / 275 °F (sterilizable and autoclavable)
Operating pressure	0.2 to 2 bar (3 to 30 psi)
Design pressure	Maximum 3 bar (42 psi) at 25 °C (77 °F)
Certificates and Approvals	
	METTLER TOLEDO Quality Certificate, EHEDG, FDA, USP Class VI, 3.1, N5/R _a 16

Other Highlights

- Small 12 mm diameter saves valuable space
- Pg 13.5 threads for interface into vessels or housing
- Variety of sensor lengths available

Features Overview

- Revolutionary design of the sensor allows for full service in seconds
- In situ measurement of CO₂
- Autoclavable and steam sterilizable
- Accurate measurement and quick response
- Long lasting and easy to maintain membranes
- FDA positive listed materials of construction
- High surface finish of N5 (R_a = 0.4 μm / 16 μin)
- EHEDG certified for cleanability
- Wetted O-rings comply with FDA and USP VI standards

▶ www.mt.com/InPro5000

Ordering Information

12 mm InPro 5000 i CO₂ Sensors

Sensor	Length	Connector Style	Order Number
InPro 5000i	120mm	K8S	30 013 606
InPro 5000i	220mm	K8S	30 019 005
InPro 5000i	320mm	K8S	30 019 006
InPro 5000i	420mm	K8S	contact METTLER TOLEDO

Transmitter

	Order Number
M100 SM 1-wire	30 365 366
M400 Type 2	30 374 112
M400 Type 3	30 374 113
M400 PA	30 026 617
M400 FF	30 026 616
M400 FF 4-wire	30 374 121
M800 Process, 1-channel	30 026 633
M800 Process, 2-channel	52 121 813
M800 Process, 4-channel	52 121 853
M800 Process 1-channel SST	30 246 551
M800 Process 2-channel SST	30 246 552
M800 Process 4-channel SST	30 246 553

InPro 5000 i Consumables

	Order Number
InPro 5000i membrane kit (4 membranes, 1 O-ring set, 25 ml of electrolyte)	52 206 055
Interior body InPro 5000 i, 120mm	30 019 049
Interior body InPro 5000 i, 220mm	30 019 170
Interior body InPro 5000 i, 320mm	30 019 175

InPro 5000 i Accessories

	Order Number
InPro 5000 i CO ₂ ISM Verification Kit	30 031 035
pH buffer 7.00	51 340 059
pH buffer 9.21	51 300 193
Cap sleeve without protective cage N-type	52 201 153
Cap sleeve with protective cage P-type	52 201 154



The InTrac® 797 e can be used to calibrate the InPro 5000 i sensor in pilot and production fermentors, without interrupting the process.



Did You Know

The InPro 5000 i membrane inhibits the passage of volatile organic acids (a common by-product of biological processes), which would otherwise interfere with CO₂ measurement.

Suitable Housings

	p.
InFit 761 e.....	112
InTrac 797 e.....	128
InTrac 781	129

InPro 5500 i Less Maintenance, Greater Reliability



Features Overview

- Direct process connections with three choices (Varivent™, Tri-Clamp™, 28 mm/M 42)
- Integrated temperature sensor
- Hygienic design, capable of withstanding CIP procedures
- O-rings with FDA approval
- Stainless steel surface with highly polished finish
- Steam sterilizable up to 120 °C (248 °F)
- Minimal and easiest membrane maintenance

▶ www.mt.com/InPro5500i

The InPro 5500 i thermal conductivity CO₂ sensor provides reliable in-line measurement of dissolved carbon dioxide for a wide spectrum of food and beverage (brewery and carbonated soft drinks) processes. Intelligent Sensor Management (ISM) technology simplifies sensor handling and reduces sensor lifecycle cost. The InPro 5500 i thermal conductivity CO₂ sensor offers outstanding features, e.g., direct process connections, and integrated temperature sensor. Its hygienic design is capable of withstanding CIP procedures. Furthermore, the sensor is equipped with ISM technology which provides unique features such as Plug and Measure, automatic sensor protection, and predictive maintenance functions (see pages 10–11).

Specifications

Performance

Measuring range	0 to 10 bar p (CO ₂)/0 to 145 psig p (CO ₂) 0 to 15 g/L CO ₂ , 0 to 7 V/V CO ₂
Accuracy in fluids	± 1 % within ± 5 % °C of calibration temperature ± 2 % over temperature range 0 to 50 °C (32 to 122 °F)
Cycle time	< 20 s
Flow requirements	min. 0.5 m/s

Construction

Measuring principle	Thermal conductivity
Cable connection (digital)	5-pin, RS485 data cable
Process connections	Varivent Type N, Tri-Clamp 2", 28 mm with cap nut M 42
Sensor body (wetted parts)	316 L stainless steel
CO ₂ selective membrane material	PTFE/Silicone (reinforced with steel mesh)
Surface roughness of wetted parts	N5 (R _a = 0.4 μm/16 μin)
O-ring material	EPDM (wetted parts), other material on request
Protection class	IP 67

Working Conditions

Operating pressure	0 to 20 bar absolute/0 to 290 psi
Design pressure	= permissible pressure range
Permissible temperature range*	0 to 50 °C (32 to 122 °F)
Operating temperature range	– 5 to 121 °C (23 to 250 °F)
Sterilization temperature	up to 120 °C (248 °F)

Certificates and Approvals

MaxCert certification package (Material Certificate 3.1, Surface Finish Certificate 2.1, Final Inspection Certificate)

Other Highlights

- Wide CO₂ detection range – 0 to 15 g/L CO₂
- Improved thermal conductivity technique for greater accuracy and low drift
- Immunity to background gases results in high CO₂ selectivity
- Predictive maintenance tools such as Dynamic Lifetime Indicator (detects when membrane replacement will be required) and Adaptive Calibration Timer (predicts when calibration should be performed)

Ordering Information**InPro 5500i Thermal Conductivity CO₂ Sensors**

Sensor	Order Number
InPro 5500i/Varivent Type N	30 034 265
InPro 5500i/Tri-Clamp 2"	30 034 266
InPro 5500i/28 mm/M42	30 034 264

Accessories

Accessories	Order Number
CalBox™	52 300 400
Purge gas conditioner	30 034 319

Cables

Cables	Order Number
– Data cable (5-pin) for InPro 5500i temperature range –30 to 80 °C (–22 to 176 °F)	
RS485/2 m (6.6 ft)	52 300 379
RS485/5 m (16.4 ft)	52 300 380
RS485/10 m (32.8 ft)	52 300 381
RS485/15 m (49.2 ft)	52 206 422
RS485/25 m (82.0 ft)	52 206 529

Spare Parts

Spare Parts	Order Number
MembraCap™	30 034 318

Transmitters

Transmitters	Order Number
M400 Type 3	30 374 113
M400/2H	30 025 514
M400/2(X)H	30 025 515
M400 FF	30 026 616
M400 PA	30 026 617
M800 SST, 1-channel	30 246 551
M800 SST, 2-channel	30 246 552
M800 Process, 1-channel	30 026 633
M800 Ethernet/IP Process, 1-channel	30 530 023
M800 Process, 2-channel	52 121 813
M800 Ethernet/IP Process, 2-channel	30 530 024
M800 Process, 4-channel	52 121 853

Process connection compatibility

Varivent, Tri-Clamp and 28 mm/M42 process connections, plus the integrated temperature sensor for more accurate CO₂ measurement, means commissioning is quick and straightforward. The hygienic membrane cap has been designed for ease of cleanability and simple, quick exchange.

**Did You Know**

The InPro 5500i can be combined with an M400 for a single loop or with an O₂ sensor using the M800 multi-channel transmitter for a complete dual O₂/CO₂ loop.



Versatile Turbidity Measurement For Multiple Industries and Applications

Turbidity measurements are important indicators in many processes as they not only influence the yield of your process but also detect factors which are detrimental to a system.

Backscattered light technology

With a single optical fiber turbidity sensor, the emitted and backscattered light travels on the same fiber. Linear measurement for medium to high levels of turbidity is possible. With a system of two optical fibers the emitted and backscattered light travels on two fibers. Sensitivity to detect particles is consequently higher.

Forward scattered light technology

This technology provides an optimum measuring range for low to medium turbidity levels. They are ideal for detection of larger particles $>0.3\mu\text{m}$ and with the simultaneous measurement of forward and direct light allows for compensation of color.

Turbidity and color monitoring

The sophisticated digital measuring technology in the InPro 86X0ie sensor is based on the photometric determination of blue and red light. Whereas the blue light is used to detect the color of the medium, in particular the color of beer, the scattering of red light is used to simultaneously detect the turbidity of the medium.

New optical product monitor

Precise monitoring of phase separation in food and beverage production is easily achieved by applying our InPro 8300 RAMS optical product monitor. Up to eight signals from long-life LEDs allow automated in-line product characterization by turbidity and color, as well as identifying products by their optical "fingerprint".

Turbidity sensor selection

METTLER TOLEDO Ingold offers several types of turbidity sensors that are optimized for specific measurement ranges and different applications. Depending on the applied technology and design they can be used in many industries such as:

- Biotechnology
- Pharmaceutical
- Chemical Processing
- Petrochemical
- Food and Beverage
- Breweries

Sensor versatility matches the requirements of diverse applications in which they can be implemented:

- Fermentation
- Biomass growth (cell density)
- Crystallization
- Phase separation
- Water in oil
- Filter breakthrough
- Activated sludge
- Post filtration of beer
- Wastewater

Our versatile turbidity measurement systems can be implemented in practically any process.

Application guide for turbidity systems

	25° and 90° scattered light	Backscattered light, 1-fiber	Backscattered light, 2-fibers	In-line product monitor
Industrial processes				
Pharmaceutical Industry				
Biotechnical applications			•	•
ChemPharma				•
Chemical Industry				•
Beverage Industry	•			•
Wastewater applications		•		•

Transmitter selection

For use with the InPro 86X0ie series, the traffic light color-coded touchscreen on the M800 1-channel Process transmitter allows operators to evaluate the sensor and process condition at a glance. The M800 1-channel also provides excellent security (setting can be password protected) and convenient operation.

Color measurement

Two precision instruments for turbidity and color in-line measurement are combined into one unique sensor. Our food and beverage industry proven InPro 86X0ie incorporates a two-angle

turbidity instrument with an EBC color monitor. Providing two sensors in one maintenance-free instrument means cost of ownership is at a minimum while reliability and easy handling are maximized.

Turbidity housing selection

Housing options are available for simple interface into a process. These housings help maintain low maintenance and minimum downtime of your process by allowing easy removal of the turbidity sensor. The housings are designed for strict Clean in Place (CIP) applications and harsh environments.



InPro 8050



InPro 8100



InPro 8200



InPro 8610ie / InPro 8630ie

Our range of turbidity sensors

Turbidity Sensors

Durable Sensors for Precise Turbidity Control

Turbidity/Optical Density

InPro 8050/InPro 8100 (Single Fiber) Wide Measurement Range



InPro 8100

InPro 8050

Single optical fiber: emitted and back-scattered light travel on same fiber.

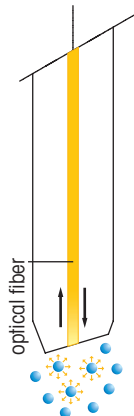

The InPro 8100 and 8050 single optical fiber turbidity sensors are designed for samples that have high particle concentrations and they offer a wide linear measuring range. The InPro 8100 is available in stainless steel and is intended for use in cell culture monitoring, pharmaceutical production, and industrial processes. The InPro 8050 utilizes a rugged polysulfone body and was developed specifically for accuracy and durability in the industrial wastewater environment.

Specifications

InPro 8050

Technology	1 – fiber
Measuring range	10 to 4000 FTU 0 to 250 g/L (diatomaceous earth as reference)
Shaft material	PSU (Polysulfone)
Shaft lengths	120 mm
Sensor diameter	12 mm
Fiber optic cable	6 m (19.7 ft), fixed
Sterilizable	No
Autoclavable	No
Explosion protection	No

InPro 8100

Technology	1 – fiber
Measuring range	10 to 4000 FTU 0 to 250 g/L (diatomaceous earth as reference)
Shaft material	Stainless steel (316L)
Shaft lengths	120, 205, 297 or 407 mm
Sensor diameter	12 mm
Surface finish	N5 (R _a = 0.4 μm / 16 μin)
Fiber optic cable	3 m (9.8 ft), fixed
Sterilizable	Yes, steam sterilizable at 130 °C (266 °F)
Autoclavable	Yes, for autoclavable version see ordering information next page

Certificates and Approvals ATEX, CE and Material certificate according to 3.1

Features Overview

- Backscattered light technology
- Uniform sensor structure reduces fouling and maintenance
- Wide measuring range
- Broad range of applications
- High accuracy

Other Highlights

- Small 12 mm diameter saves valuable space
- Pg 13.5 threads for interface into housings
- Integrated fiber optic cable
- Variety of sensor lengths available

▶ www.mt.com/InPro8100
▶ www.mt.com/InPro8050

Ordering Information

InPro 8050	Length	Shaft Material	Order Number
InPro 8050	120 mm	PSU	52 800 209

InPro 8100	Length	Shaft Material	Order Number
InPro 8100	120 mm	Stainless steel	52 800 205
InPro 8100	205 mm	Stainless steel	52 800 206
InPro 8100	297 mm	Stainless steel	52 800 207
InPro 8100	407 mm	Stainless steel	52 800 208
InPro 8100 autoclavable sensor	120 mm	Stainless steel	contact METTLER TOLEDO
InPro 8100 autoclavable sensor	205 mm	Stainless steel	contact METTLER TOLEDO
InPro 8100 autoclavable sensor	297 mm	Stainless steel	contact METTLER TOLEDO
InPro 8100 autoclavable sensor	407 mm	Stainless steel	contact METTLER TOLEDO

Accessories	Order Number
CaliCap calibration accessory	52 800 210
Fiber cable extension kit 3 m (9.8 ft)	52 800 228
Fiber cable extension kit 5 m (16.4 ft)	52 800 229
Fiber cable extension kit 6 m (19.7 ft)	52 800 230
Fiber cable extension kit 10 m (32.8 ft)	52 800 231
Fiber cable extension kit 15 m (49.2 ft)	52 800 232
Fiber cable extension kit 20 m (65.6 ft)	52 800 233
Fiber cable extension kit 25 m (82.0 ft)	52 800 234
Fiber cable extension kit 30 m (98.4 ft)	52 800 235
Couplings to link fiber cables (two included in every kit)	52 800 240
Coupling box IP65 (NEMA 4X)	52 800 241
Swagelok™ adapter NPT 1/2"	52 800 242

Longer cable lengths are available. Please contact METTLER TOLEDO Ingold for details.

Transmitter	Order Number
M800 Process 1-channel	30 026 633

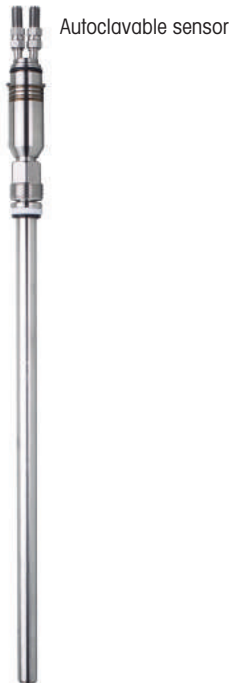

Suitable Housings	p.
InFit 761 e.....	112
InFit 762 e/763 e.....	118
InFlow	122
InDip	120
InTrac 779 e.....	127
InTrac 799 e.....	128
InTrac 785	130

Turbidity Sensors

Durable Sensors for Precise Turbidity Control

Turbidity/Optical Density

InPro 8200 (Dual Fiber) High Resolution at Medium Turbidity



Two optical fibers:
for emitted and
backscattered
light protected by
scratch resistant
sapphire window.

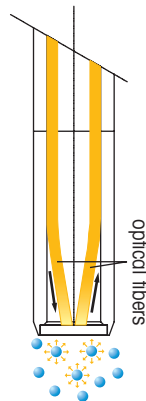

The InPro 8200 dual optical fiber turbidity sensor is designed for samples with medium to high concentration and where high resolution is a requirement. The InPro 8200 is available in stainless steel or Hastelloy™ and is intended for use in cell culture monitoring, crystallization control, and industrial processes including liquid/solid separation.

Specifications

Technology	2-fiber
Measuring range	5 to 4000 FTU 0 to 30 g/L (diatomaceous earth as reference)
Shaft material	Stainless steel (316L) Hastelloy
Shaft lengths	120, 205, 297 or 407 mm
Sensor diameter	12 mm
Surface finish	N5 ($R_a = 0.4 \mu\text{m} / 16 \mu\text{in}$)
Fiber optic cable	3 m (9.8 ft), fixed
Sterilizable	Yes, steam sterilizable at 130 °C (266 °F)
Autoclavable	No
Certificates and Approvals	ATEX, CE and Material certificate according to 3.1

Features Overview

- Backscattered light technology
- Uniform sensor structure reduces fouling and maintenance
- Wide measuring range
- Broad range of applications
- High accuracy
- Sapphire window

Other Highlights

- Small 12 mm diameter saves valuable space
- Pg 13.5 threads for interface into housings
- Integrated 3 m (9.8 ft) fiber optic cable
- Variety of sensor lengths available

▶ www.mt.com/InPro8200

Ordering Information

Sensor	Length	Shaft Material, Window Seal	Order Number
InPro 8200	120 mm	Stainless steel, Epoxy	52 800 216
InPro 8200	205 mm	Stainless steel, Epoxy	52 800 217
InPro 8200	297 mm	Stainless steel, Epoxy	52 800 218
InPro 8200	407 mm	Stainless steel, Epoxy	52 800 219
InPro 8200	120 mm	Hastelloy, Epoxy	52 800 220
InPro 8200	205 mm	Hastelloy, Epoxy	52 800 221
InPro 8200	297 mm	Hastelloy, Epoxy	52 800 222
InPro 8200	407 mm	Hastelloy, Epoxy	52 800 223
InPro 8200/S/Kalrez®-FDA/120	120 mm	Stainless steel, Kalrez®-FDA	52 800 224
InPro 8200/S/Kalrez®-FDA/205	205 mm	Stainless steel, Kalrez®-FDA	52 800 225
InPro 8200/S/Kalrez®-FDA/297	297 mm	Stainless steel, Kalrez®-FDA	52 800 226
InPro 8200/S/Kalrez®-FDA/407	407 mm	Stainless steel, Kalrez®-FDA	52 800 227
InPro 8200/H/Kalrez®-FDA/120	120 mm	Hastelloy, Kalrez®-FDA	Contact METTLER TOLEDO
InPro 8200/H/Kalrez®-FDA/205	205 mm	Hastelloy, Kalrez®-FDA	52 800 264
InPro 8200/H/Kalrez®-FDA/297	297 mm	Hastelloy, Kalrez®-FDA	Contact METTLER TOLEDO
InPro 8200/H/Kalrez®-FDA/407	407 mm	Hastelloy, Kalrez®-FDA	52 800 215

Accessories	Order Number
CaliCap calibration accessory	52 800 210
Fiber cable extension kit 3 m (9.8 ft)	52 800 228
Fiber cable extension kit 5 m (16.4 ft)	52 800 229
Fiber cable extension kit 6 m (19.7 ft)	52 800 230
Fiber cable extension kit 10 m (32.8 ft)	52 800 231
Fiber cable extension kit 15 m (49.2 ft)	52 800 232
Fiber cable extension kit 20 m (65.6 ft)	52 800 233
Fiber cable extension kit 25 m (82.0 ft)	52 800 234
Fiber cable extension kit 30 m (98.4 ft)	52 800 235
Couplings to link fiber cables (two included in every kit)	52 800 240
Coupling box IP 65 (NEMA 4X)	52 800 241
Swagelok adapter NPT ½"	52 800 242

Longer cable lengths are available. Please contact METTLER TOLEDO Ingold for details.

Transmitter	Order Number
M800 Process 1-channel	30 026 633



Did You Know

The CaliCap™ calibration accessory can serve two important functions. Firstly, it can be used as a “dry check” to verify the performance of the Transmitter/Sensor combination. Secondly, it provides stable measurement during off-line calibration in small vessels where reflection can disturb the measurement.



Suitable Housings	p.
InFit 761 e.....	112
InFit 762 e/763 e.....	118
InFlow	122
InDip	120
InTrac 779 e.....	127
InTrac 799 e.....	128
InTrac 785	130

Turbidity Sensors

Durable Sensors for Precise Turbidity Control

Turbidity/Optical Density

InPro 8610ie/InPro 8630ie Turbidity Sensor

Reliable Measurement for Tight Process Control



CE

ISM®



Features Overview

- Real-time window fouling surveillance
- Plug and Measure startup
- ISM provides real-time information on sensor condition
- Automatic color or turbidity compensation

Other Highlights

- Compliance with international standards
- Hygienic design
- 12-point turbidity and 6-point color factory pre-calibration over the entire measuring range

The innovative InPro 8610ie and InPro 8630ie turbidity sensors combine precision technology with advanced measurement electronics in one compact sensor head, and provide highly reliable measurements at a reduced installation cost. The forward and 25° sideward scattered light measurement technology in the InPro 8610ie and InPro 8630ie are designed to provide dependable turbidity measurements in the low to medium particle concentration range. Additionally, the InPro 8630ie sensor includes 90° scattered light measurement and a blue LED light source. The 90° scattered light is very sensitive to measuring turbidity in liquids with small undissolved particles such as beer proteins and glucanes. While the blue LED enables color measurement, which is especially useful in beer and sugar processing applications.

Specifications

Measuring principle	Turbidity: Scattered light (25°/90°**) Color**: Absorption measurement
Light source	Turbidity: 650nm, LED Color: 430nm, LED
Measuring range	0 to 1000 EBC 0 to 4000 FTU 0 to 50 EBC Color
Units	FTU, NTU, EBC, ASBC, mg/l, ppm, %T
Resolution	0.001 EBC
Process connection	Tuchenhagen-VARINLINE™ Type N50/40
Wetted materials	Hastelloy C22, sapphire windows
Surface finish	N6/Ra 32 (Ra ≤ 0.8 μm/32 μin)
Process pressure	–10 °C to +120 °C (14 to 248 °F) (max. +150 °C peak for 15 mins during SIP/CIP cleaning)
Process temperature	up to 16 bar (232 psi)
Communication	Digital (RS485)
Power supply	24 VDC (±15%), 1.5 W, supply by transmitter
Certificate and Approvals	METTLER TOLEDO Quality Certificate, CE, PED, EHEDG, EC 1935/2004 compliant

** InPro 8630ie only

▶ www.mt.com/InPro8600i

Ordering Information

Sensor	Order Number
InPro 8610ie	30 541 120
InPro 8630ie	30 541 121

Transmitter	Order Number
M800 Process 1-channel	30 026 633

Cables	Order Number
2 m (6.6 ft)	52 300 379
5 m (16.4 ft)	52 300 380
10 m (32.8 ft)	52 300 381
15 m (49.2 ft)	52 206 422

Accessories	Order Number
Verification Kit for InPro 86X0ie	30 562 310

Process Connection

InPro 86X0ie series sensors are hygienically designed to be installed with a Tuchenhagen-VARINLINE™ access unit type N. The VARINLINE access unit provides maximum cleanliness through zero deadleg design. Standard fittings are provided with butt weld pipe ends but may also be configured with sanitary, male or female NPT or ANSI flanged end connections.

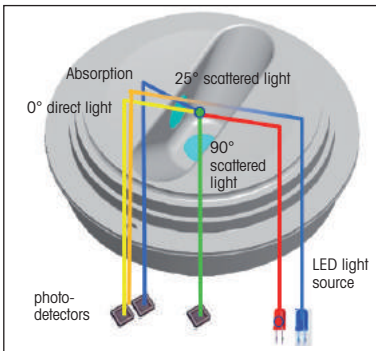

25°/90° scattered light from InPro 8630ie

Forward/90° scattered light sensors: Ratio measurement for color compensation

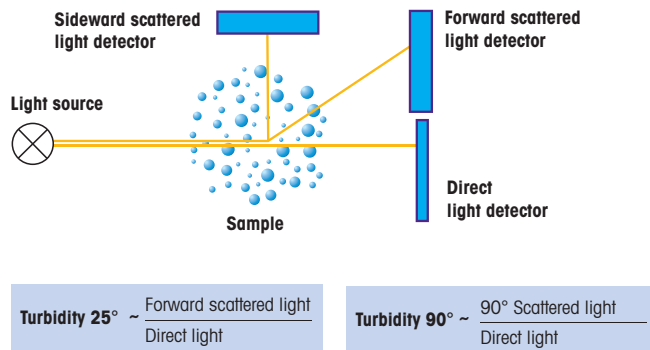

InPro 8300 RAMS Series Optical Product Monitoring and Identification Systems



Features Overview

- Monitoring of turbidity and color using one single unit
- Use of durable and long-lasting LEDs
- Excellent zero stability
- Configuration using a PC or notebook
- Easy to retrofit to VARINLINE access units or VARINLINE sight glasses without the need of welding
- In parallel to processing the switching outputs and the analog output in the PLC, visualization via a separate PC is possible

The InPro 8300 RAMS is an optical multi-switch for monitoring product/water phase separation processes and for the identification of products in the process. In process automation applications, the unit supplies the switching signal for product/water or product/product phase separation. Where a range of products is manufactured, it allows unique identification of the different products. Using up to four different wavelengths, the transmitted light and the back-scattered light are measured. This method allows virtually all liquids to be monitored, independently of their color and turbidity.

Specifications

Main Module		
Measuring cycle (all 8 parameters)		approx. 5 measurements per second
Reaction time		≤ 1 s
Measuring range	TCS	0...100% Absorption turbidity or color system
	BASIC	0...100% Absorption and/or reflection at four wavelengths for product identification
	CAL/COMBINE	Turbidity 0...50/100/200/500/1000 EBC (factory calibrated) Color 0...15/30/60/150 EBC (factory calibrated)
Repeatability		± 1 % of measuring range
Power supply		24VDC ± 5 %
Power consumption		< 50 mA plus total of output currents, polarity reversal protection up to 30 V
Output signal		4...20 mA Calibrated Range or 0...100% Abs./refl.
Configuration interface		RS 232
Operating conditions		
Ambient temperature		0 to 40 °C (32 to 104 °F)
Product temperature		0 to 105 °C (32 to 221 °F) (140 °C/284 °F optional)
Rel. humidity		0 to 100 %
Protection class		IP 67
Materials		
Housing		1.4404
Seals		EPDM/optional Viton®
Viewing window		PVC
Cable glands		brass/nickel plated
OPL-Bits		
Housing material		1.4404
Sealing material		EPDM, optional Viton®
Window material		Borosilicate, sapphire (optional)
Operating pressure		max. 10 bar
Mechanical temp. resistance		- 5 to + 180 °C (23 to 356 °F) (depending on the sealing material)

► www.mt.com/InPro8300

Ordering Information

Accessories InPro 8300 RAMS	Order Number
OPL bit 0 mm borosilicate window	52 801 153
OPL bit 8 *mm borosilicate window	52 801 124
OPL bit 19 *mm borosilicate window	52 801 125
OPL bit 22 *mm borosilicate window	52 801 126
OPL bit 37 *mm borosilicate window	52 801 127
OPL bit 42 *mm borosilicate window	52 801 128
OPL bit 47 *mm borosilicate window	52 801 129
OPL bit 58 *mm borosilicate window	52 801 130
O-ring set for active and passive part 34.59 x 2.62 mm, EPDM	52 801 150
O-ring set for OPL-Bits, EPDM (FDA)	52 801 151
Desiccant	52 801 134

* Optional available with sapphire window.

Configurator InPro 8300 RAMS

16-17 Type											
BA BASIC											
TC TCS (Turbidity or Color System)											
CA CALI											
CO COMBINE											
19 Temperature											
S Standard											
H High Temperature											
21-22 OPL-bit 1 for detector side											
00 (0 mm/0°)											
08 (8 mm/0.315°)											
19 (19 mm/0.748°)											
22 (22 mm/0.866°)											
37 (37 mm/1.457°)											
42 (42 mm/1.654°)											
47 (47 mm/1.850°)											
58 (58 mm/2.283°)											
24-25 OPL-bit 2											
00 (0 mm/0°)											
08 (8 mm/0.315°)											
19 (19 mm/0.748°)											
22 (22 mm/0.866°)											
37 (37 mm/1.457°)											
42 (42 mm/1.654°)											
47 (47 mm/1.850°)											
58 (58 mm/2.283°)											
27 Window											
B Borosilicate											
S Sapphire											
29-31 Diameter											
25 DN 25											
40 DN 40											
50 DN 50											
65 DN 65											
80 DN 80											
100 DN 100											
150 DN 150											
33 Measurement											
T Turbidity											
C Color											
Calibration 1			Calibration 2			Calibration 3					
min	max		min	max		min	max				
Ordering Code:											
InPro 8300 RAMS/		/	/	/	/	/	/	/	/	/	/
1-15	16-17	18	19	20	21-22	23	24-25	26	27	28	

InPro 8300 RAMS



InPro 8300 RAMS software "CONFI"

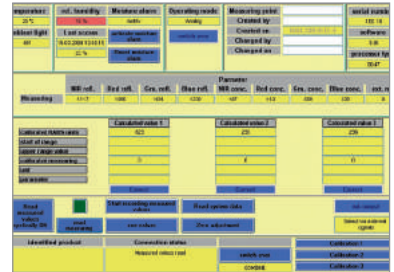

Other Highlights

- A PC can be connected to record measured data (min. 3s increments)
- Product identification can be displayed in table or chart form
- Easy copying of data into Excel™
- Automatic self-monitoring of condensation forming on the optical windows
- Sapphire windows available as an option
- High-temperature version available as an option

Conductivity/Resistivity Systems

When Optimal Performance Is Essential

Electrolytic conductivity is a widely used analytical parameter for water purity analysis, monitoring of reverse osmosis, cleaning procedures, control of chemical processes, and in industrial wastewater.

Three commonly used techniques

Electrolytic conductivity is a measure of the total ionic content of a solution. There are three main methodologies to measure conductivity:

- 2-electrode sensors are for measurements in high purity water and relatively low conductivity ranges
- 4-electrode sensors are for mid to high ranges. They are more resistant to fouling than 2-electrode designs
- Inductive sensors cover mid to very high conductivity ranges, and are particularly resistant to fouling.

METTLER TOLEDO offers all three methodologies.

2-electrode sensor design

An AC voltage is applied across the two electrodes, and the resistance between them is measured. The built-in temperature sensor provides fast accurate measurement. The cell geometry and the high solution resistance allow for very accurate and precise conductivity determination.

Sensors are used for: water conditioning and purification stages where they are capable of detecting minute levels of impurities in ultrapure water.

4-electrode sensor design

An AC voltage is applied across the two outside electrodes. The principle is to measure the voltage drop across the two inner electrodes. This eliminates polarization errors. Since this technique measures potential drop the measurement remains accurate.

It permits easier in-line cleaning and it can be installed in smaller piping than inductive sensors.

Sensors are used for: concentration measurement of acids, alkalis, and salt process streams.

Inductive sensor design

The inductive or “electrodeless” conductivity sensor consists of two toroidal coils encapsulated in an inert polymer body. When placed in a conductive solution, a current loop is generated proportional to the conductivity of the solution.

They are ideal for very high conductivity measurements as found in chemical processes, and aggressive applications where contacting electrodes may not be suitable.

Continuous conductivity monitoring according to USP <645>

USP guideline <645> sets a standard for the quality assessment of USP waters based on measurement of the electrolytic conductivity. There is a 3-stage test in which stage 1 allows on-line, non-temperature compensated conductivity measurement. There are specific requirements for the sensors and transmitters (see table).

Application guide for conductivity sensors

Where to use	InGold sensors										
	InPro 7000-VP	InPro 7001-VP	InPro 7002-TC-VP	InPro 7005-VP	InPro 7108-25-VP	InPro 7108-TC-VP	InPro 7108-VP/CPVC	InPro 7108-VP/PEEK	InPro 7100/InPro 7100i	InPro 7250HT PEEK & PFA	InPro 7250ST PEEK
Pure and ultrapure water	•	•									
Sanitary			•								
Water purification				•				•			
SIP					•	•					
Industrial wastewater						•			•	•	
Medium/high conductivity							•	•	•		
Aggressive chemicals								•	•		
Chemical applications								•	•	•	
Pharmaceutical water								•			
High conductivity									•		
Chemical concentration									•		

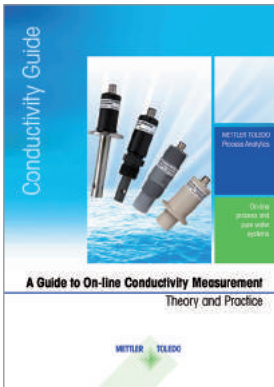

Find out more in our comprehensive conductivity theory guide at www.mt.com/conductivity-guide

Specification	USP <645>
Conductivity sensor and cell constant accuracy	Verify cell constant within $\pm 2\%$ using a reference solution
Conductivity meter calibration	NIST traceable 0.1% precision resistors in place of sensor
Instrument resolution	0.1 $\mu\text{S}/\text{cm}$
Instrument accuracy at 1.3 $\mu\text{S}/\text{cm}$	0.1 $\mu\text{S}/\text{cm}$
Temperature compensation	Must be read uncompensated
Instrument dynamic range	10^2

METTLER TOLEDO instruments meet USP <645> water conductivity requirements.



InPro 7250 HT



InPro 7108-VP/PEEK



InPro 7005-VP



InPro 7002-TC-VP



InPro 7100i

InPro 7000-VP 2-Electrode Design



InPro 7000-VP



InPro 7005-VP



InPro 7002-VP



InPro 7001-VP



The InPro 7000-VP series are 2-electrode conductivity sensors designed for high accuracy measurements in very low to medium conductivity water. The sensors are available in a wide selection of process connections to meet every application need. Series includes hygienic and sterilizable designs.

Ordering Information

InPro 7000-VP Series 2-Electrode Sensors	Order Number
InPro 7000-VP	52 001 995
InPro 7005-VP	52 001 996
InPro 7001/120-VP 3.1	52 001 997
InPro 7001/225-VP 3.1	52 001 998
InPro 7002/1.5" TC-VP 3.1	52 001 999
InPro 7002/2" TC-VP 3.1	52 002 000
InPro 7002-VAR-VP 3.1	52 002 857

Cables

Cables	Order Number
1.5m (4.9ft)	58 080 201
3.0m (9.8ft)	58 080 202
4.5m (14.8ft)	58 080 203
7.5m (24.6ft)	58 080 204
15.0m (49.2ft)	58 080 205
25.0m (82.0ft)	58 080 206
30.0m (98.4ft)	58 080 207
Adapter (VP to old patch cord, 1 m/3.3ft)	58 080 101

Features Overview

- Watertight VarioPin connector (IP68) for easy connection and excellent signal transmission
- MaxCert certification package includes NIST/ASTM traceable cell constant, 3.1 materials certificate, and FDA compliant materials documentation

Typical Applications

- Water conditioning and preparation in the chemical, pharmaceutical and food and beverage industries

► www.mt.com/InPro7000

Specifications

	InPro 7000-VP	InPro 7005-VP	InPro 7001-VP	InPro 7002-VP
Measurement principle	2-electrode sensor	2-electrode sensor	2-electrode sensor	2-electrode sensor
Electrode material	Titanium	Titanium	SS 316L	SS 316L
Body material	PVDF	PTFE-coated. SS 316/1.4401	SS 316L	SS 316L
RTD	Built-in Pt 1000	Built-in Pt 1000	Built-in Pt 1000	Built-in Pt 1000
Insertion length	29 mm (1.15")	34 mm (1.35")	120/225 mm (4.71/8.86")	85/104 mm (3.35/4.09")
Max. sensor length	153.20 mm (6.03")	75 mm (2.95")	194/299 mm (7.64/11.77")	156/175 mm (6.14/6.88")
Process connection	¾" NPT 1" NPT conduit	¾" NPT	Pg 13.5	Tri-Clamp 1.5" Tri-Clamp 2" Tuchenhagen- VARIVENT DN 40–DN125
Measuring range	See separate table below			
Cell constant nominal	0.1 cm ⁻¹	0.1 cm ⁻¹	0.1 cm ⁻¹	0.1 cm ⁻¹
Cell constant accuracy	±1.0%	±1.0%	±1.0%	±1.0%
Working Conditions				
Max. pressure at 25 °C (77 °F)	34 bar (493 psig)	17 bar (246 psig)	17 bar (246 psig)	31 bar (449.5 psig)
Max. pressure at 95 °C (203 °F)	7 bar (100 psig)	7 bar (100 psig)	7 bar (100 psig)	10 bar (145 psig)
Measuring temperature range	-10...100 °C (14...212 °F)	-10...100 °C (14...212 °F)	-10...100 °C (14...212 °F)	-10...120 °C (14...248 °F)
Temperature range (sterilization)	N/A	N/A	Sterilizable -10...131 °C (14...268 °F)	Sterilizable -10...155 °C (14...311 °F)
Temperature accuracy at 25 °C (77 °F)	±0.25 °C (±0.5 °F)	±0.25 °C (±0.5 °F)	±0.25 °C (±0.5 °F)	±0.25 °C (±0.5 °F)
Design				
Temperature compensation	Pt 1000 IEC class A	Pt 1000 IEC class A	Pt 1000 IEC class A	Pt 1000 IEC class A
Cable connection	Vario Pin (IP 68)	Vario Pin (IP 68) ^a	Vario Pin (IP 68)	Vario Pin (IP 68)
Wetted parts:				
- Metals	Titanium (Grade 2)	Titanium (Grade 2)	SS 316L	SS 316L
- Plastics	PVDF (FDA)	PTFE-coated. SS 316/1.4401		
- O-rings	Viton® (FDA)	Viton® (FDA)	Viton® (FDA)	Viton® (FDA)
- Insulation	PEEK (FDA)	PEEK (FDA)	PEEK (FDA)	PEEK (FDA)
- Surface roughness of wetted metal parts ^b	N/A	N/A	Polished N4 (R _a < 0.2 μm) (R _a < 8 μin)	Electropolished N4 (R _a < 0.2 μm) (R _a < 8 μin)
Certificates and Approvals				
Cell constant	•	•	•	•
CE certificate	•	•	•	•
Material certificate EN 10204 3.1	-	-	•	•
Material confirmation EN 10204 2.1	•	•	•	•
Surface roughness	-	-	•	•
ATEX (II 1/2G Ex ia)	•	•	•	•

^a The VP is at the end of an approx. 0.5 m (1.64 ft) long fixed cable. ^b Except at active electrode areas.

Measuring Ranges 2 - Electrode Design Sensors

Sensors	Transmitters				
	M300	M400 4 - W	M400 2 - W	M800 1 - channel	System Accuracy (±)
InPro 7000-VP/7005-VP	0.02–2000	0.02–2000	0.02–2000	0.02–2000	3%
InPro 7001-VP	0.02–500	0.02–500	0.02–500	0.02–500	3%
InPro 7002-VP	0.02–2000	0.02–2000	0.02–2000	0.02–2000	3%

all values in μS/cm

Suitable Housings	p.
InTrac 781	129

Conductivity Sensors

Absolutely Reliable, Absolutely Precise

Conductivity

InPro 7100-VP 4-Electrode Design



InPro 7108-25-VP

InPro 7108-VP/PEEK



InPro 7108-TC-VP

InPro 7108-VP/CPVC



InPro 7108-VAR

The InPro 7100-VP series conductivity sensors utilize 4-electrode technology to expand the range of contacting conductivity for the measurement of medium to high conductivity solutions. The rugged sensor design withstands the most rigorous CIP/SIP procedures in food and pharmaceutical industries. Series includes process connections for industrial processing as well as hygienic 25 mm port and Tri-Clamp fittings.

Ordering Information

InPro 7100-VP Series 4-Electrode Sensors	Order Number
InPro 7108-VP/CPVC	52 002 001
InPro 7108-VP/PEEK	52 002 002
InPro 7108-VP/PEEK/HA-C22	52 002 003
InPro 7108-VP-25/40-VP	52 002 004
InPro 7108-VP-25/40/HA-C22-VP	52 002 005
InPro 7108-VP-25/65-VP	52 002 006
InPro 7108-VP-25/65/HA-C22-VP	52 002 007
InPro 7108-VP/1.5" TC-VP	52 002 008
InPro 7108/2" TC-VP	52 002 009
InPro 7108-VAR-VP 3.1	52 002 790

Cables	Order Number
1.5m (4.9ft)	58 080 201
3.0m (9.8ft)	58 080 202
4.5m (14.8ft)	58 080 203
7.5m (24.6ft)	58 080 204
15.0m (49.2ft)	58 080 205
25.0m (82.0ft)	58 080 206
30.0m (98.4ft)	58 080 207
Adapter (VP to old patch cord, 1m/3.3ft)	58 080 101

Features Overview

- No polarization effects
- Withstands over 200 sterilization cycles (where applicable)
- Smooth flat surfaces resist fouling
- Watertight VarioPin connector (IP68) for easy connection and excellent signal transmission
- MaxCert certification package includes NIST/ASTM traceable cell constant, 3.1 materials certificate, and FDA compliant materials documentation

- WideRange™ technology for wide measuring range and compact, cost-efficient installation

Typical Applications

- Chemical concentration measurement/control
- Detection of phase separation
- Control of CIP processes
- Wastewater monitoring

www.mt.com/InPro7100

Specifications

	InPro 7108–VP/CPVC	InPro 7108–VP/PEEK	InPro 7108–25-VP	InPro 7108–TC–VP InPro 7108–VAR–VP
Measuring principle	4-electrode sensor	4-electrode sensor	4-electrode sensor	4-electrode sensor
Electrode material	316L	Sterilizable 316L or HA-C22	Sterilizable 316L or HA-C22	Sterilizable 316L
Body material	CPVC	PEEK	PEEK	PEEK
RTD	Built-in Pt 1000	Built-in Pt 1000	Built-in Pt 1000	Built-in Pt 1000
Insertion length	28 mm (1.10")	28 mm (1.10")	40/65 mm (1.57/2.56")	25 mm (0.98")
Max. sensor length	151 mm (5.96")	126.7 mm (4.99")	123/148 mm (4.86/5.84")	105 mm (4.14")
Process connection	1" NPT 1" NPT conduit	1" NPT	DN25	Tri-Clamp 1.5" Tri-Clamp 2" Tuchenhagen- Varivent DN 40–DN125
Measuring range	See separate table on page 77			
Cell constant nominal	0.25 cm ⁻¹	0.25 cm ⁻¹	0.25 cm ⁻¹	0.25 cm ⁻¹
Working Conditions				
Max. pressure at 25 °C (77 °F)	7 bar (100 psig)	17 bar (246 psig)	17 bar (246 psig)	17 bar (246 psig)
Max. pressure at 95 °C (203 °F)	–	7 bar (100 psig)	7 bar (100 psig)	7 bar (100 psig)
Measuring temperature range	–10...80 °C (14...176 °F)	–10...140 °C ^a (14...284 °F)	–10...140 °C ^a (14...284 °F)	–10...140 °C ^a (14...284 °F)
Temperature range (sterilization)	N/A	Sterilizable –10...140 °C ^a (14...284 °F)	Sterilizable –10...140 °C ^a (14...284 °F)	Sterilizable –10...140 °C ^a (14...284 °F)
Temperature accuracy at 25 °C (77 °F)	±0.25 °C ±0.5 °F	±0.25 °C ±0.5 °F	±0.25 °C ±0.5 °F	±0.25 °C ±0.5 °F
Design				
Temperature compensation	Pt 1000 IEC class A	Pt 1000 IEC class A	Pt 1000 IEC class A	Pt 1000 IEC class A
Cable connection	Vario Pin (IP 68)	Vario Pin (IP 68)	Vario Pin (IP 68)	Vario Pin (IP 68)
Wetted parts:				
– Metals	316L	316L or HA-C22	316L or HA-C22	316L
– Plastics	CPVC	PEEK (FDA)	PEEK (FDA)	PEEK (FDA)
– O-rings	N/A	N/A	EPDM (FDA)	N/A
Certificates and Approvals				
Cell constant	•	•	•	•
CE certificate	•	•	•	•
Material certificates				
EN 10204 3.1	•	•	•	•
Material confirmation 2.1	•	•	•	•
ATEX (II 1/2G Ex ia)	•	•	•	•

^a Short term 150 °C (302 °F)

InPro 7100 (i) Convenient Sensors for All Your Processes



InPro 7100

InPro 7100i

Features Overview

- Wide measurement range (0.02–500 mS/cm, depending on the transmitter)
- High resistance against aggressive chemicals
- Compatible with a variety of our static and retractable housing
- WideRange technology

The InPro 7100 is particularly suited for applications in the Chemical Industry, Pharmaceutical Industry, Food & Beverage and Pulp & Paper. The fast response time allows quick detection of process changes, leading to better process control. The PEEK shaft material offers high resistivity against aggressive solutions and is particularly suitable in process with frequent CIP/SIP cycles. The InPro 7100 is compatible with a variety of static (InDip® or InFit® series) and retractable (InTrac® series) housings giving the user a wide choice of installation options.

Specifications

Performance

Cell constant nominal	0.31 cm ⁻¹
System accuracy	± 5 % or better
Operation range	0 to 20 bar at 135 °C (0 to 290 psi at 275 °F) 0 to 10 bar at 150 °C (0 to 145 psi at 302 °F)
Temperature range (sterilization)	Sterilizable –20 to 150 °C (–4 to 302 °F)
Temperature accuracy at 25 °C (77 °F)	± 0.1 °C (± 0.1 °F)

Construction

Measuring principle	4-electrode sensor
Electrode material	SS 316L/1.4435 Hastelloy C22
Body material	PEEK
RTD	Built-in Pt1000
Sensor diameter	12 mm
Sensor length	120 mm (4.72"), 225 mm (8.85"), 425 mm (16.73")
Process connection	Pg 13.5, (with InFit series: Tri-Clamp 1.5", Tri-Clamp 2", Cap nut DN 25)

Design

Temperature compensation	Pt 1000 IEC class A
Cable connection	InPro 7100: Vario Pin (IP 68); InPro 7100i: AK9
Wetted parts:	– Metals: SS 316L/1.4435 or Hastelloy C22 – Plastics: PEEK (FDA; USP Class VI)

Certificates and Approvals

Cell constant, ATEX, Material certificate 2.1 and 3.1, CE

ISM Features

- Digital connector
- Plug and Measure functionality

Typical Applications

- Chemical concentration control
- Control of CIP processes
- Control of digesting and bleaching (Pulp & Paper)
- Detection of phase separation (Food & Beverages)
- Buffer preparation (Pharma)

► www.mt.com/InPro7100

Ordering Information

InPro 7100

Sensor	Order Number
InPro 7100/12/120/4435	52 003 571
InPro 7100/12/120/C22_	52 003 572
InPro 7100/12/425/4435	52 003 793
InPro 7100/12/425/C22_	52 003 794

InPro 7100 i

Sensor	Order Number
InPro 7100i/12/120/4435	52 003 791
InPro 7100i/12/120/C22_	52 003 792
InPro 7100i/12/225/4435	30 095 803
InPro 7100i/12/425/4435	52 003 880
InPro 7100i/12/425/C22_	52 003 881

VP Patch Cables

1.5 m (5 ft)	58 080 201
3.0 m (10 ft)	58 080 202
4.6 m (15 ft)	58 080 203
7.6 m (25 ft)	58 080 204
15.2 m (50 ft)	58 080 205
22.9 m (75 ft)	58 080 206
30.5 m (100 ft)	58 080 207

AK9 Coax Cables with K8S Connector for ISM sensors

Cable Socket	Termination	Cable Length	Order Number
AK9	Tinned ends	1 m (3.3 ft)	59 902 167
AK9	Tinned ends	3 m (9.8 ft)	59 902 193
AK9	Tinned ends	5 m (16.4 ft)	59 902 213
AK9	Tinned ends	10 m (32.8 ft)	59 902 230
AK9	Tinned ends	20 m (65.6 ft)	52 300 204

For accessories, cables and cable lengths refer to page 142.

Measuring Ranges 4-Electrode Design Sensors

Sensors	Transmitters						System Accuracy (±)
	M100	M200	M300	M400 4-W	M400 2-W	M800	
InPro 7108	–	–	0.02–650	0.02–650	0.02–650	0.02–650*	5 %
InPro 7100	–	–	0.02–400	0.02–400	0.02–400	0.02–400*	5 %
InPro 7100i	0.02–500	0.02–500	0.02–500	0.02–500	0.02–500	0.02–500	5 %

All values in mS/cm

* M800 1-channel only

Suitable Housings	p.
InTrac 781	129

InPro 7250 Inductive Conductivity Sensors



Features Overview

- Inductive design ideal for dirty applications or process chemical concentration measurement
- No polarization effects
- High temperature model suitable for boiler blowdown applications
- Chemically resistant PEEK body for very aggressive chemicals
- PFA version available for harsh environments
- Robust design for maintenance-free operation
- Available bushings and flanges simplify installation

► www.mt.com/InPro7250

The InPro 7250 Series conductivity sensors are inductive sensors designed to handle aggressive chemical solutions or dirty water applications. These “electrodeless” sensors have no electrodes in contact with the sample and are not affected by coatings that foul traditional contacting conductivity sensors. Able to measure medium to very high conductivity levels, applications range from measurement of industrial wastewater to acid, caustic, and salt stream concentration in industrial processing.

Specifications

High Temperature (HT)	PEEK	PFA
Measurement range	0–2,000 mS/cm	0–2,000 mS/cm
Temperature range	–20 to 180 °C (–4 to 356 °F)	–20 °C to 125 °C (–4 to 257 °F)
Pressure range at 25 °C (77 °F)	0–20 bar (0–290 psi)	0–16 bar (0–232 psi)
Sensor material	PEEK, glass filled	PFA, not glass filled
Seal material	Viton®	PTFE
Temperature sensor	Pt1000	Pt1000
Cell factor	2.175	2.30
Process connection	G ¾"	G ¾"
Cable length	3 m, 5 m, 10 m (9.8 ft, 16.4 ft, 32.8 ft)	3 m, 5 m, 10 m (9.8 ft, 16.4 ft, 32.8 ft)
Certificates and Approvals	ATEX: • FM: • CE: •	• • •

Standard

Temperature (ST)	PEEK
Measurement range	0–2,000 mS/cm
Temperature range	–20 to 100 °C (–4 to 212 °F)
Pressure range at 25 °C (77 °F)	0–8 bar (0–116 psi)
Sensor material	PEEK, glass filled
Seal material	Viton®
Temperature sensor	Pt1000
Cell factor	2.175
Process connection	G ¾"
Cable length	3 m, 5 m, 10 m (9.8 ft, 16.4 ft, 32.8 ft)
Certificates and Approvals	CE: •

Ordering Information

Sensors	Order Number
InPro 7250 ST/Pt1000/3m (9.8ft)	52 002 736
InPro 7250 ST/Pt1000/5m (16.4ft)	52 002 737
InPro 7250 ST/Pt1000/10m (32.8ft)	52 002 738
InPro 7250 HT/Pt1000/3m (9.8ft)	52 002 739
InPro 7250 HT/Pt1000/5m (16.4ft)	52 002 740
InPro 7250 HT/Pt1000/10m (32.8ft)	52 002 741
InPro 7250 PFA/Pt1000/3m (9.8ft)	52 005 423
InPro 7250 PFA/Pt1000/5m (16.4ft)	52 005 424
InPro 7250 PFA/Pt1000/10m (32.8ft)	52 005 425

Other sensor cable lengths are available. Please contact METTLER TOLEDO for details.

Process Connections and Accessories	Order Number	
– Flanges		
Flange DN 50/PN16	52 403 565	
Flange ANSI 2"	52 403 567	
Flange ANSI 3"	52 403 569	
Flange DN50/PN16, PVDF, only for PFA version	52 403 946	
Flange ANSI 2", incl. Sealing Plate PTFE	52 403 947	
– Bushings		
Bushing R 1½"	52 403 446	
Bushing R 1½", PVDF	52 403 447	
Bushing R 2"	52 403 448	
Bushing R 2", PVDF	52 403 449	
Bushing 1½" NPT	52 403 450	
Bushing 1½" NPT, PVDF	52 403 451	
Bushing 2" NPT	52 403 452	
Bushing 2" NPT, PVDF	52 403 453	
– Sanitary Adapters		
Dairy adapter DN50	52 403 583	
Aseptic adapter DN50	52 403 584	
– InDip 550 Ind – Sensor holder spare part set		
InDip 550ind PVC	52 403 579	
InDip 550ind PVDF	52 403 580	
– Accessories		
Flat gasket (Viton®)	52 403 432	
O-ring (Viton®)	52 750 171	
Locknut (stainless steel)	52 403 433	
Transmitter M400 (4-Wire Transmitter)	Designation	Order Number
M400, Type 1 Cond Ind	–	52 121 495
Transmitter M400 (2-Wire Transmitter)	Designation	Order Number
M400 2XH Cond Ind	–	30 256 307

Transmitters for All Parameters Your Access to the Process

Constant information

Transmitters are the components that communicate to the user and translate sensor readings into displayed measurements. METTLER TOLEDO provides tailorable transmitter solutions to meet the needs of a wide range of applications and functional requirements. Intelligent diagnostics keep users informed of sensor "health".

Single- or multi-channel?

For simpler processes where only a single parameter requires measurement, a single-channel transmitter is the obvious choice, but for processes where more than one parameter must be monitored, multi-channel, multi-parameter transmitters offer sig-

nificant advantages. METTLER TOLEDO multi-channel transmitters combine operating flexibility with ease of use.

Transmitters for hazardous areas

Many of our transmitters have been designed specifically for hazardous area use where there is a risk of explo-



	M200 (p. 82–83)	M300 (p. 84–85)	M400 (p. 86–89)	M800 (p. 92–95)	
	4-Wire				
Channels	1/2	1/2	1	1/2/4*	
Plug and Measure	•	•	•	•	
Dynamic Lifetime Indicator (DLI)	–	•	•	•	
Adaptive Calibration Timer (ACT)	–	•	•	•	
Time To Maintenance (TTM)	–	•	•	•	
Calibration history	–	•	•	•	
CIP/SIP autoclaving counter	–	•	•	•	
iMonitor	–	•	•	•	
Communication	–	–	HART® FOUNDATION fieldbus*	Profinet* Ethernet/IP*	
Panel Cutout	½ DIN, ¼ DIN	½ DIN, ¼ DIN	½ DIN	½ DIN	
Mixed-mode input	–	•	•*	•*	
PID controller	–	•	•	•	
Hold input	•	•	•	•	
Analog input	–	–	1*	1	
Digital input	1/2	1/2	2	4/5/6	
Relays/open collectors (OC)	2	4*	4	8/2/0*	
Outputs	2/4	2/4	4	8/1/0*	
Approvals	UL	UL	ATEX IECEx Zone 2 FM CI 1 Div 2 CSA CI 1 Div 2* NEPSI	FM CI 1 Div 2*	
Parameter compatibility (Ingold)					
pH/ORP	•	•	•	•	
Dissolved oxygen					
Amperometric sensors					
High (InPro 68xxi)	•	•	•	•	
Low (InPro 69xxi)	–	–	•*	•	
Optical sensors					
High (InPro 68xx)	–	–	•	•	
Low (InPro 69xx)	–	–	•*	•	
Gaseous oxygen					
High (InPro 68xx)	–	–	•*	•	
Low (InPro 69xx)	–	–	•*	•	
GPro 500	–	–	•*	–	
CO₂					
InPro 5000i	–	–	•*	•	
InPro 5500i	–	–	•*	•	
Conductivity 2-e/4-e	•	•	•	•	
Inductive conductivity	–	–	•*	–	
Turbidity	–	–	–	•*	
Ozone	•	•	•*	–	
EasyClean™ compatibility	•	•	•	•	

sive or toxic environments. Low-power, 2-wire units with ATEX/FM approvals ensure operating safety.

Digital communication

We offer transmitters for all common digital communication protocols for easy interface with your DCS or PLC. Intelligent Sensor Management (ISM) diagnostics data can also be accessed on control systems to provide an over-

view of the performance of all measurement systems from one point.

The way forward

Use of digital sensors is becoming increasingly common in the process industries. Many of our transmitters accept traditional analog as well as ISM digital sensors, providing a future oriented investment in your plant. Our latest transmitter developments

include the M400 and M300 Process multi-parameter units. Their touchscreen display and intuitive menus save operating time, while predictive maintenance ensures reliability and reduced maintenance. The M100 series has been designed to provide the ultimate solution for measurement point simplicity. This displayless transmitter sets a new standard in measuring system simplicity and efficiency.



	M80 SM (p. 98)	M100 SM (p. 97)	M100 DR (p. 96)	M400 2(X)H (p. 100–103)	M400 FF (p. 100–103)	M400 PA (p. 100–103)
			2-Wire			
	1	1	1	1	1	1
	•	•	•	•	•	•
	•	•	•	•	•	•
	•	•	•	•	•	•
	•	•	•	•	•	•
	•	•	•	•	•	•
	–	–	–	–	–	–
	MODBUS RTU	BT 4.0 MODBUS RTU	HART®	HART®	FOUNDATION fieldbus	Profibus PA
	–	–	–	½ DIN	½ DIN	½ DIN
	–	–	–	•	•	•
	–	–	–	•	•	•
	–	–	•	•	–	–
	–	–	1	1	1	1
	–	–	1	2	2	2
	–	–	–	2	–	–
	–	2	1	2	–	–
	–	–	–	ATEX IECEx Zone 1* FM CI 1 Div 1/2* NEPSI*	ATEX IECEx Zone 1 FM CI 1 Div 1 NEPSI	ATEX IECEx Zone 1 FM CI 1 Div 1 NEPSI
	•	•	•	•	•	•
	•	•	•	•	•	•
	–	–	•	•	•	•
	–	•	–	–	•	•
	–	–	–	–	•	•
	–	–	–	•*	•	•
	–	–	–	•*	•	•
	–	–	–	–	–	–
	•	•	–	–	•	•
	–	–	–	–	–	•
	•	–	•	•	•	•
	–	–	–	•*	–	–
	–	–	–	–	–	–
	–	–	–	–	–	–
	–	–	–	•	•	•

* Model dependent

M200: Convenient and Reliable For Basic Process Applications



The M200 multi-parameter transmitter line covers pH, ORP, dissolved oxygen, ozone and conductivity measurements. Plug and Measure provides compatibility and reliable operation for ISM sensors as well as the complete digital easySense™ line. Convenient operation thanks to the large display, plain text interface, quick access menu and easily accessible wiring terminals. With the Transmitter Configuration Tool (TCT) provided for the M200 commissioning as well as maintenance becomes substantially easier.

Specifications

Measurement parameters	pH, ORP, dissolved oxygen, conductivity and ozone
ISM	Plug and Measure
Power supply	100V to 240VAC or 20 to 30VDC, 10 VA
AC Frequency	50 to 60 Hz
Current (analog) outputs	2 × or 4 × 0/4 – 20 mA, 22 mA alarm, galvanically isolated from input and from earth/ground
User interface	Backlit LCD, 4 lines
Languages	8 (English, German, French, Italian, Spanish, Portuguese, Russian and Japanese)
Ambient temperature	–10 to 50 °C (14 to 122 °F)
Relative humidity	0 to 95 % non-condensing
Rating	IP65
Hold input	yes
Control input	2 (1 for single channel)
Relays	2-SPDT (alarm delay 0 to 999 s)

Features Overview

- Plug and Measure for easy operation and maintenance
- Input for digital ISM sensor signals and easySense sensors
- Multi-parameter unit
- 1 or 2-channel version
- 2 configurable relays
- IP65 rated
- 8 languages: English, German, French, Italian, Spanish, Portuguese, Russian and Japanese

Other Highlights

- 4-wire installation
- Quick setup mode for fast commissioning
- Free Transmitter Configuration Tool (TCT) software

Parameter Specifications

pH/ORP

Measurement parameters	pH, mV and temperature
pH range	-2.00 to 16.00 pH
ORP input range	-1500 to 1500 mV
pH resolution	Auto/0.01/0.1/1 (can be selected)
pH accuracy	±1 digit
Temperature measuring range	-30 to 130 °C (-22 to 266 °F)
Temperature resolution	Auto/0.001/0.01/0.1/1 °C/°F (can be selected)
Temperature accuracy	±1 digit
Calibration	1-point (offset), 2-point, process
Sensor maximum distance	80 m (260 ft)

Dissolved oxygen

Measurement parameters	Dissolved oxygen (DO) saturation or concentration and temperature
DO concentration range	0.00 to 50.00 ppm (mg/L)
DO saturation range	0 to 500 %, air, 0 to 0 to 200 % O ₂
DO resolution	Auto/0.001/0.01/0.1/1 (can be selected)
DO accuracy	±1 digit
Temperature measuring range	-10 to +80 °C (14 to 176 °F)
Temperature resolution	Auto/0.001/0.01/0.1/1 °C/°F (can be selected)
Temperature accuracy	±1 digit
Calibration	1-point (slope or offset), process (slope or offset)
Sensor maximum distance	80 m (260 ft)

Conductivity

Measurement parameters	Conductivity and temperature
Cond range 2-electrode sensor	0.1 to 40000 mS/cm (25 Ω × cm to 100 MΩ × cm)
Cond range 4-electrode sensor	0.01 to 650 mS/cm (1.54 Ω × cm to 0.1 MΩ × cm)
Cond / Res resolution	Auto/0.001/0.01/0.1/1 (can be selected)
Cond / Res accuracy	± 1 digit
Temperature measuring range	-40 to 200 °C (-40 to 392 °F)
Temperature resolution	Auto/0.001/0.01/0.1/1 °C/°F (can be selected)
Temperature accuracy	±1 digit
Chemical concentration curves	NaCl 0–26 % @ 0 °C to 0–28 % @ +100 °C NaOH 0–12 % @ 0 °C to 0–16 % @ +40 °C to 0–6 % @ +100 °C HCl 0–18 % @ -20 °C to 0–18 % @ 0 °C to 0–5 % @ +50 °C HNO ₃ 0–30 % @ -20 °C to 0–30 % @ 0 °C to 0–8 % @ +50 °C H ₂ SO ₄ 0–26 % @ -12 °C to 0–26 % @ +5 °C to 0–9 % @ +100 °C H ₃ PO ₄ 0–35 % @ +5 °C to 80 °C TDS ranges NaCl, CaCO ₃
Calibration	1-point (slope), 2-point, process
Sensor maximum distance, DS 4-e	80 m (260 ft)
Sensor maximum distance ISM 2-e	90 m (300 ft)

Ordering Information

Transmitter	Order Number
M200, ¼ DIN, single-channel	52 121 554
M200, ½ DIN, single-channel	52 121 555
M200, ¼ DIN, dual-channel	52 121 556
M200, ½ DIN, dual-channel	52 121 557

Accessories

	Order Number
Pipe mounting kit for ½ DIN	30 300 480
Panel mounting kit for ½ DIN	52 500 213
Protective hood	52 500 214
Terminal blocks for M200, M300, M400	52 121 504

Detailed description and order information for easySense sensors and fittings see pages 228–229.

M300 Process: Versatile and User-Friendly For a Wide Range of Applications and Industries



Features Overview

- 4.0" touchscreen
- Multi-parameter transmitter for pH/ORP, DO, ozone and cond
- Available as single-channel or dual-channel version
- PID controller with pulse length, pulse frequency or analog control
- User management available

Other Highlights

- Mixed-mode functionality allows the connection of analog or digital ISM sensors
- Full ISM diagnostics available
- 4-wire installation
- Also communicates with EasyClean systems for automatic sensor cleaning

► www.mt.com/M300

The multi-parameter M300Process transmitter line for pH/ORP, dissolved oxygen, dissolved ozone and conductivity measurements offers exceptional measurement performance as well as excellent user ergonomics.

The high contrast black and white touchscreen together with the harmonized menu structure for all parameters, facilitates navigation and ensures easy and user friendly operation.

On-line diagnostics information allows you to schedule sensor maintenance or replacement. The clearly visible diagnostic information lets you know when it's time to do maintenance or calibration of sensors equipped with Intelligent Sensor Management (ISM) technology.

The integrated USB interface allows you to use it for data logging or to store the configuration on a USB stick.

Specifications

Power supply	100 to 240 VAC, or 20 to 30 VDC, 10 VA
Frequency for AC	50 to 60 Hz
Current output	2 × 0/4 to 20 mA (4× for dual channel), 22 mA alarm (according to Namur NE43)
Display	4.0" b/w touchscreen, 320 × 240 pixel
Languages	10 (English, German, French, Italian, Spanish, Portuguese, Russian, Japanese, Korean and Chinese)
Ambient temperature	–10 to 50 °C (14 to 122 °F)
Relative humidity	0 to 95% non-condensing
Rating	¼ DIN: IP65 (front) ½ DIN: IP65
PID controller	Yes
Control input (Hold)	1 or 2 (dual channel version)
Relays	2 × SPDT, 2 × reed
Approvals and certificates	cULus
USB interface	1 × USB Host: Data logging and configuration storage on USB stick 1 × USB Device: Software update interface

Parameter Specifications

pH Performance	
Measurement parameters	pH, mV, and temperature
pH, ORP input range*	– 1500 to 1500 mV
pH display range	–2 to 16 pH
pH resolution	Auto/0.01/0.1/1 (can be selected)
Relative accuracy**	± 0.02 pH; ± 1 mV
Temperature input*	Pt1000 (Pt100 with adapter)
Temperature measuring range	–30 to 130 °C (–22 to 266 °F)
Temperature accuracy**	± 0.25 °C (± 0.45 °F)
Sensor maximum distance	Analog: 10 to 20 m (33 to 65 ft) ISM: 80 m (260 ft)
Calibration	1- or 2-point, process

* not required for ISM sensors

** for analog input signal (ISM signal causes no additional error)

Parameter Specifications (cont.)

DO Performance

Measurement parameters	DO saturation or concentration and temperature
Measuring current range	0 to 900 nA
DO concentration range	0.00 to 50.00 ppm (mg/L)
DO accuracy	± 0.5% of full scale reading
DO resolution	Auto/0.001/0.01/0.1/1 (can be selected)
Temperature input*	NTC 22
Temperature measuring range	-10 to 80 °C (14 to 176 °F)
Temperature accuracy**	± 0.25 °C (± 0.45 °F)
Sensor maximum distance	Analog: 20 m (65 ft). ISM: 80 m (260 ft)
Calibration	1-point (slope or offset), process (slope or offset)

* not required for ISM sensors ** for analog input signal (ISM signal causes no additional error)

Conductivity Performance

Measurement parameters	Conductivity, and temperature
Conductivity/resistivity ranges	2-electrode sensor display range: 0 to 40,000 mS/cm (25 Ω × cm to 100 MΩ × cm) 4-electrode sensor display range: 0.01 to 650 mS/cm (1.54 Ω × cm to 0.1 MΩ × cm)
Temperature input*	PT 1000
Temperature measuring range	-40 to 200 °C (-40 to 392 °F)
Sensor maximum distance	Analog 2-e: 61 m (200 ft); analog 4-e: 15 m (50 ft) ISM 2-e: 90 m (300 ft); ISM 4-e: 80 m (260 ft)
Cond/Res accuracy**	± 0.5% of reading or 0.25 Ω, whichever is greater
Cond/Res repeatability	± 0.25% of reading or 0.25 Ω, whichever is greater
Cond/Res resolution	Auto/0.001/0.01/0.1/1 (can be selected)
Temperature resolution	Auto/0.001/0.01/0.1/1 °C (°F) (can be selected)
Temperature accuracy**	± 0.25 °C (± 0.45 °F)
Temperature repeatability**	± 0.13 °C (± 0.23 °F)

* not required for ISM sensors ** for analog input signal (ISM signal causes no additional error)

Dissolved Ozone Performance

Measurement parameters	Concentration and temperature
Display range for current	Analog: 0 to -7000 nA
Ozone measuring range	Short term: 0 to 5.00 ppm (mg/L) O ₃ Continuous: 0 to 500 ppb (µg/L) O ₃
Ozone accuracy*	Analog: ± 0.5% of reading or ± 5 ppb
Resolution	± 1 digit
Temperature compensation	Automatic
Temperature measuring range	0 to 50 °C (32 to 122 °F)
Temperature resolution	Auto/0.001/0.01/0.1/1 (can be selected)
Temperature accuracy*	Analog: ± 0.25 °C (± 0.45 °F)
Sensor maximum distance	80 m (260 ft)
Calibration	1-point (offset) or process (slope and offset)

* for analog input signal (ISM input signal causes no additional error)

Ordering Information

For Analog Sensors

	Order Number
M300 Process, ¼ DIN, single-channel, multi-parameter	30 280 770
M300 Process, ½ DIN, single-channel, multi-parameter	30 280 771
M300 Process, ¼ DIN, dual-channel, multi-parameter	30 280 772
M300 Process, ½ DIN, dual-channel, multi-parameter	30 280 773

Installation Accessories for ½ DIN Version

	Order Number
Pipe mount kit for ½ DIN	30 300 480
Panel mount kit for ½ DIN	30 300 481
Wall mounting kit for ½ DIN	30 300 482
Protective hood	30 073 328

M400: Reliable and Intelligent Advanced Process Control



The multi-parameter M400 transmitter series features Intelligent Sensor Management (ISM) technology and covers pH/ORP, oxygen (for measurement of dissolved oxygen or in gas), dissolved carbon dioxide, dissolved ozone, conductivity or GPro 500 TDL, depending on the type you choose.

The high-contrast black and white touchscreen together with four soft keys, allows you to operate the transmitter even in the harshest applications without compromising user ergonomics. The online diagnostic information with harmonized menu display lets you know when it is time to do maintenance or calibration of sensors equipped with ISM technology. The HART or FOUNDATION fieldbus communication protocol provides easy integration of sensor diagnostics into process control systems.



Features Overview

- 4" touchscreen plus soft-key operation
- Advanced ISM diagnostics, incl. iMonitor
- Communication protocol: 4 to 20 mA (with HART)
- Multi-parameter measurement
- Aluminum die cast enclosure (coated)
- 4-wire installation

Specifications

General

Power supply	100 to 240VAC, or 20 to 30VDC, 10VA
Frequency for AC	50 to 60 Hz
Current output	4 × 0/4 to 2 mA, 22 mA alarm (according to Namur NE43) (except M400 FF 4-wire)
Display	4.0" TFT b/w touchscreen, 320 × 240 pixels
Languages	10 (English, German, French, Italian, Spanish, Portuguese, Russian, Japanese, Korean and Chinese)
Ambient temperature	-20 to +50 °C (-4 to 122 °F)
Relative humidity	0 to 95 % non-condensing
Rating	IP66 NEMA 4X
Approvals	Type 1, 2, 3: cCSAus Class I Division 2, ATEX IECEX Zone 2, cFMus Class I Division 2, NEPSI Zone 2 Foundation fieldbus: cULus
PID process controller	Yes
Control input (Hold)	2
USB interface	1 × USB Host: Data logging and configuration storage on USB stick 1 × USB Device: Software update interface

Other Highlights

- Plug and Measure functionality
- IP 66 rated
- Graphic trending
- Transmitter configuration tool



Did You Know

With tools such as the Dynamic Lifetime Indicator, Time To Maintenance and Adaptive Calibration Timer, ISM technology on the M400 offers true predictive maintenance, resulting in fewer unscheduled shutdowns.

► www.mt.com/M400

Parameter Specifications

pH/ORP (incl. pH/pNa)

Measurement parameters	pH, mV and temperature
pH display range	-2.00 to +16.00 pH
pH resolution	Auto/0.001/0.01/0.1/1 (can be selected)
pH accuracy ¹⁾	Analog: ± 0.02 pH
mV range	-1500 to +1500 mV
mV resolution	Auto/0.001/0.01/0.1/1 mV (can be selected)
mV accuracy ¹⁾	Analog: ± 1 mV
Temperature input ²⁾	Pt 1000/Pt 100/NTC 22k
Temperature measuring range	-30 to +140 °C (-22 to +284 °F)
Temperature resolution	Auto/0.001/0.01/0.1/1 (can be selected)
Temperature accuracy ¹⁾	Analog: ± 0.25 °C (± 0.45 °F)
Temperature compensation	Automatic/Manual
Max. sensor cable length	Analog: 10 to 20 m (33 to 65 ft) depending on sensor ISM: 80 m (260 ft)
Calibration	1-point, 2-point or process

1) ISM input signal causes no additional error.

2) Not required on ISM sensors

Amperometric oxygen

Measurement parameters	Dissolved oxygen (DO): Saturation or concentration and temperature Oxygen in gas: Concentration and temperature
Measuring current range	Analog: 0 to -7000 nA
Oxygen display ranges	Dissolved oxygen Saturation: 0 to 500 % air, 0 to 200 % O ₂ -sat Concentration: 0 ppb ($\mu\text{g/L}$) to 50.00 ppm (mg/L) In gas Saturation: 0 to 100 vol-% O ₂ Concentration: 0 to 9999 ppb O ₂ gas
Oxygen accuracy ¹⁾	Dissolved oxygen: Saturation ± 0.5 % of the measured value or ± 0.5 %, depending on which is larger. Concentration at high values: ± 0.5 % of the measured value or ± 0.050 ppm/ ± 0.050 mg/L, depending on which is larger. Concentration at low values: ± 0.5 % of the measured value or ± 0.001 ppm/ ± 0.001 mg/L, depending on which is larger In gas: ± 0.5 % of the measured value or ± 5 ppb, depending on which is larger for ppm O ₂ gas. ± 0.5 % of the measured value or ± 0.01 %, depending on which is larger for vol-% O ₂ .
DO resolution	Auto/0.001/0.01/0.1/1 (can be selected)
Polarization voltage	O ₂ High: Cal/Meas: -675 mV (configurable) O ₂ Low: Cal: -675 mV, Meas: -500 mV (configurable)
Temperature input	Pt 1000/Pt 100/NTC 22k
Temperature compensation	Automatic
Temperature measuring range	-10 to +80 °C (+14 to +176 °F)
Temperature resolution	Auto/0.001/0.01/0.1/1 °C (°F) (can be selected)
Temperature accuracy ¹⁾	± 0.25 °C (± 0.45 °F)
Max. sensor cable length	Analog: 20 m (65 ft) ISM: 80 m (260 ft)
Calibration	1-point (slope and offset) or process (slope and offset)

1) ISM input signal causes no additional error.

Optical oxygen

Measurement parameters	Dissolved oxygen (DO): Saturation or concentration and temperature Oxygen in gas: Concentration and temperature
Oxygen display ranges	Dissolved oxygen Saturation: 0 to 500 % air, 0 to 200 % O ₂ -sat Concentration: 0 ppb ($\mu\text{g/L}$) to 50.00 ppm (mg/L) In gas Saturation: 0 to 100 vol-% O ₂ Concentration: 0 to 9999 ppb O ₂ gas
Oxygen accuracy	± 1 digit
Oxygen resolution	Auto/0.001/0.01/0.1/1 (can be selected)
Temperature compensation	Automatic
Temperature measuring range	-30 to +150 °C (-22 to +302 °F)
Temperature resolution	Auto/0.001/0.01/0.1/1 °C (°F) (can be selected)
Temperature accuracy	± 1 digit
Max. sensor cable length	80 m (260 ft)
Calibration	1-point (depending on sensor model) 2-point or process, process scaling

Dissolved carbon dioxide

Measurement parameters	Dissolved carbon dioxide and temperature
CO ₂ display range	0 to 5000 mg/L 0 to 200% sat 0 to 1500 mm Hg 0 to 2000 mbar 0 to 2000 hPa
CO ₂ accuracy	± 1 digit
CO ₂ resolution	Auto/0.001/0.01/0.1/1 (can be selected)
mV range	-1500 to +1500 mV
mV resolution	Auto/0.01/0.1/1 mV (can be selected)
mV accuracy	± 1 digit
Total pressure range	0 to 4000 mbar
Temperature measuring range	-30 to +150 °C (-22 to +302 °F)
Temperature resolution	Auto/0.001/0.01/0.1/1 °C (°F) (can be selected)
Temperature accuracy	± 1 digit
Max. sensor cable length	80 m (260 ft)
Calibration	1-point (offset), 2-point (slope and offset) or process (offset)

CO₂ hi (thermal conductivity)

Measurement parameters	Dissolved carbon dioxide and temperature
CO ₂ display ranges	0 to 10 bar p (CO ₂)/0 to 145 psi p (CO ₂) 0 to 15 g/L 0 to 7 V/V CO ₂
Accuracy in fluids ¹⁾	± 1 % of reading (within ± 5 % of calibration temperature) ± 2 % of reading over temperature range 0 to 50 °C (32 to 122 °F)
Calibration	1-point or process

1) Complete loop of sensor and transmitter

GPro 500 TDL

Measurement parameters	O ₂ , O ₂ and temperature, CO (ppm), CO (%) , H ₂ O, CO ₂ (%), H ₂ S, HCl
Gas display ranges	0 to 100 %
Gas accuracy, resolution, repeatability and low detection limit	Depending on sensor model
Linearity	Better than 1 %
Drift	Negligible (< 2 % of measurement range between maintenance intervals)
Sampling rate	1 second
Response time (t ₉₀)	Depending on sensor model
Process pressure ranges	Depending on sensor model
Process temperature ranges	0 to 250 °C (32 to 482 °F) optional (for probe installation) 0 to 600 °C (32 to 1112 °F) with additional thermal barrier 0 to 150 °C (32 to 302 °F) (white cell)
Max. sensor cable length	40 m (130 ft) (FM version)
Calibration	1-point (offset) or process (slope or offset)

Dissolved ozone

Measurement parameters	Concentration and temperature
Display range for current	Analog: 0 to -7000 nA
Ozone measuring range	0 to 5000 ppb (µg/L) O ₃
Ozone accuracy	± 1 % (or 0.4 ppb) up to 2000 ppb ± 2.5 % (or 50-125 ppb) from 2000 to 5000 ppb
Resolution	± 1 digit
Temperature compensation	Automatic
Temperature measuring range	5 to +50 °C (+41 to +122 °F)
Temperature resolution	Auto/0.001/0.01/0.1/1 (can be selected)
Temperature accuracy 1)	Analog: ± 0.25 °C (± 0.45 °F)
Max. sensor cable length	80 m
Calibration	1-point (offset) or process (slope and offset)

Conductivity 2-e/4-e

Measurement parameters	Conductivity/resistivity and temperature
Conductivity ranges	See sensor specification
Chemical concentration curves (used with 4-e sensors)	NaCl: 0–26 % @ 0 °C to 0–28 % @ +100 °C NaOH: 0–12 % @ 0 °C to 0–16 % @ + 40 °C to 0–6 % @ +100 °C HCl: 0–18 % @ –20 °C to 0–18 % @ 0 °C to 0–5 % @ +50 °C HNO ₃ : 0–30 % @ –20 °C to 0–30 % @ 0 °C to 0–8 % @ +50 °C H ₂ SO ₄ : 0–26 % @ –12 °C to 0–26 % @ + 5 °C to 0–9 % @ +100 °C H ₃ PO ₄ : 0–35 % @ + 5 °C to + 80 °C
TDS ranges	NaCl, CaCO ₃
Cond/Res accuracy ¹⁾	Analog: ±0.5 % of reading or 0.25 Ω, whichever is greater
Cond/Res repeatability ¹⁾	Analog: ±0.25 % of reading or 0.25 Ω, whichever is greater
Cond/Res resolution	Auto/0.001/0.01/0.1/1 (can be selected)
Temperature input	PT1000
Temperature measuring range	–40 to +200 °C (–40 to +392 °F)
Temperature resolution	Auto/0.001/0.01/0.1/1 (can be selected)
Temperature accuracy (±0.90 °F) outside	Analog: ±0.25 °C (±0.45 °F) within –30 to +150 °C (–22 to +302 °F); ±0.50 °C
Max. sensor cable length	Analog: 2-e sensors: 61 m (200 ft); 4-e sensors: 15 m (50 ft) ISM: 2-e sensors: 90 m (300 ft); 4-e sensors: 80 m (260 ft)
Calibration	1-point, 2-point or process

1) ISM input signal causes no additional error.

Ordering information

Transmitter	Order Number
M400 Type 1 ISM	30 490 171
M400 Type 2 ISM	30 490 172
M400 Type 1 Cond Ind	52 121 495
M400 Type 1	30 374 111
M400 Type 2	30 374 112
M400 Type 3	30 374 113
M400 FF 4-wire	30 374 121

Installation Accessories

Installation Accessories	Order Number
Pipe mounting kit for ½ DIN	30 300 480
Panel mount kit for ½ DIN	30 300 481
Wall mounting kit for ½ DIN	30 300 482
Protective hood	30 073 328

M400 Parameter Fit Guide

	M400 Type 1 *		M400 Type 2 *		M400 Type 3		M400 FF 4-Wire		M400 Type 1 Cond Ind	
	Analog	ISM	Analog	ISM	Analog	ISM	Analog	ISM	Analog	ISM
pH/ORP	•	•	•	•	•	•	•	•	–	•
pH/pNa	–	•	–	•	–	•	–	•	–	•
UniCond 2-e/4-e	–	•	–	•	–	•	–	•	–	–
Conductivity 2-e	•	–	•	–	•	–	•	–	–	–
Conductivity 4-e	•	•	•	•	•	•	•	•	–	•
Amp. DO ppm/ppb/trace	–	–	•/• ¹⁾ /–	•/• ¹⁾ /–	•/•/•	•/•/•	•/•/•	•/•/•	–	–
Opt. DO ppm/ppb	–	–	–/–	•/• ²⁾	–	•/•	–	•/• ²⁾	–	–
Amp. O ₂ gas ppm/ppb/trace	–	–	–/–/–	–/–/–	•/•/•	•/•/•	•/•/•	•/•/•	–	–
Opt. O ₂ gas ppm	–	–	–	–	–	•	–	•	–	–
Dissolved ozone	–	–	•	•	•	•	–	•	–	–
Dissolved carbon dioxide	–	–	•	•	•	•	•	•	–	–
CO ₂ hi	–	–	–	–	–	•	–	–	–	–
GPro 500 TDL	–	–	–	–	–	•	–	–	–	–
Inductive conductivity	–	–	–	–	–	–	–	–	•	–

* M400 Type 1 ISM and Type 2 ISM models support ISM parameters only.

1) Thornton high performance DO sensor only.

2) Pure water optical DO sensor only.

M400 Type 1 Cond Ind: Reliable Transmitter For Inductive Conductivity Sensors



The M400 Type 1 Cond Ind is a 4-wire, single-channel process transmitter designed specifically for use with analog inductive conductivity sensors. A large four line backlit Liquid Crystal Display conveys measuring data and setup information. The menu structure allows the operator to modify all operational parameters by using keys on the front panel. A menu-lockout feature, with password protection, is available to prevent the unauthorized use of the meter. The transmitter M400 Type1 Cond Ind can be configured to use its four analog and / or six relay outputs for process control.

Specifications

General	
Power supply	100 to 240VAC, or 20 to 30VDC, 10VA
Frequency for AC	50 to 60Hz
Current output	4 × 0/4 to 20mA
Display	4 line backlit LCD with 5 tactile keys
Enclosure	Polycarbonate
Languages	8 (English, German, French, Italian, Spanish, Portuguese, Russian and Japanese)
Ambient temperature	-20 to 50 °C (-4 to 122 °F)
Relative humidity	0 to 95 % non-condensing
Rating	IP65
Approvals	cFMus Class I Division 2
PID process controller	Yes
Control input (Hold)	2
USB interface	1 × USB Device: Provide real-time data output, instrument configuration capabilities and software update interface via PC

Other Highlights

Versatile Mixed-Mode Input

Multi-parameter transmitter for advanced process control, with analog input for inductive conductivity and digital input for pH/ORP.

Intelligent Measuring Solutions

Keep your process under control with ISM for low cost of ownership and real-time status information from the sensor for true predictive maintenance

Minimized Maintenance Costs

The ISM Plug and Measure feature allows measurement readiness within seconds. Simplified commissioning minimizes risk of installation troubles

Inductive Conductivity Specifications

Measurement ranges	See sensor specification
Chemical concentration curves	NaCl: 0–26% @ 0°C to 0–28% @ +100°C NaOH-1: 0–13% @ 0°C to 0–24% @ +100°C NaOH-2: 15–50% @ 0°C to 35–50% @ +100°C HCl-1: 0–18% @ –20°C to +50°C HCl-2: 22–39% @ –20°C to +50°C HNO ₃ -1: 0–30% @ –20°C to +50°C HNO ₃ -1: 35–96% @ –20°C to +50°C H ₂ SO ₄ -1: 0–26% @ –12°C to 0–37% @ +100°C H ₂ SO ₄ -2: 28–88% @ 0°C to 39–88% @ +95°C H ₂ SO ₄ -3: 94–99% @ –12°C to 89–99% @ +95°C H ₃ PO ₄ : 0–35% @ +5°C to +80°C User-defined concentration table (5×5 matrix)
TDS ranges	NaCl, CaCO ₃
Sensor maximum distance	10 m
Cond/Ind accuracy	±1% of reading ±0.005 mS/cm
Cond/Ind repeatability	±1% of reading ±0.005 mS/cm
Cond/Ind resolution	Auto/0.01/0.01/0.1 (can be selected)
Temperature input	Pt1000/Pt100/NTC22K
Temperature measuring range	–40 to +200.0°C (–40 to 392°F)
Temperature resolution	Auto/0.001/0.01/0.1/1 K (°F) (can be selected)
Temperature accuracy	±0.25 K (±0.45°F) within –30 to 150°C ±0.50 K (±0.90°F) outside
Temperature repeatability	±0.13 K (±0.23°F)
Max. sensor cable length	Analog: 10 to 20 m (33 to 65 ft) depending on sensor ISM: 80 m (260 ft)
Calibration	1-point, zero or process

Ordering information

Transmitter	Order Number
M400 Type 1 Cond Ind	52 121 495

Installation Accessories	Order Number
Pipe mounting kit for ½ DIN	30 300 480
Panel mount kit for ½ DIN	30 300 481
Wall mounting kit for ½ DIN	30 300 482
Protective hood	30 073 328

Parameter Fit Guide

For the Parameter Fit Guide for the M400 transmitters (all versions) please refer to page 89. The information for the M400 Type 1 Cond Ind is in the last column.

M800: Multi-Parameter, Multi-Channel Transmitter

Touch the Future



Features Overview

- Color touchscreen
- Intuitive operation
- Premium ISM functionality
- Multi-parameter measurement
- 1-/2-/4-channel versions
- iMonitor™
- User management and logbook

Other Highlights

- 8 current outputs
- 8 output relays
- Traffic light coded sensor information
- IP 66 rated
- 2 PID process controllers

► www.mt.com/M800

The M800 transmitter series features premium Intelligent Sensor Management (ISM) technology measuring pH/ORP, optical DO, amperometric oxygen (DO as well as O₂ gas), dissolved carbon dioxide, turbidity and conductivity. The multi-parameter transmitter accepts any compatible combination of ISM sensors. Up to four channels of process measurement provides immediate Plug and Measure installation and operation, predictive sensor maintenance and dynamic lifetime status. The color touchscreen ensures intuitive operation, with user selectable control and alarm management.

Specifications

General Specification

Measurement parameters	pH/ORP, amperometric and optical oxygen, conductivity, dissolved carbon dioxide, turbidity and temperature
ISM	Plug and Measure, advanced diagnostics (Dynamic Lifetime Indicator, Adaptive Calibration Timer, CIP/SIP counter etc.), iMonitor
Power supply	100 to 240VAC, or 20 to 30VDC, 12VA
AC frequency	50 to 60 Hz
Current (analog) outputs ¹⁾	8 × 0/4 to 20 mA, 22 mA alarm
User interface	Color touchscreen 5.7", resolution 320 × 240 px, 256 colors
Languages	10 (English, German, French, Italian, Spanish, Portuguese, Russian, Japanese, Korean and Chinese)
Ambient temperature	-20 to 50 °C (-4 to 122 °F)
Relative humidity	0 to 95 %, non-condensing
Rating	IP66
PID process controller	2
Control input (Hold)	Yes
Analog input	Yes
Alarm contact	Yes (alarm delay 0 to 999 s)
Measuring range	Parameter and sensor depending
Measuring accuracy	± 1 digit (sensor depending)
Measuring repeatability	± 1 digit (sensor depending)
Measuring resolution	Auto/0.001/0.01/0.1/1 (can be selected)

1) Not supported on Profinet model; 1 current output on Ethernet/IP model.



Did You Know

The M800 1-channel transmitter with mixed mode functionality supports analog and digital ISM sensors.

EtherNet/IP™
PROFINET

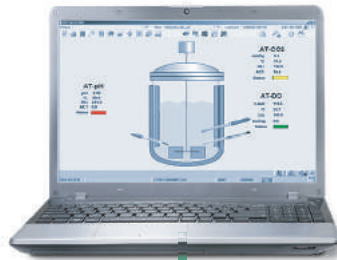

ISM®



Other Highlights of Profinet and Ethernet/IP multi-parameter transmitters

- Pure digital communication within loop and real-time sensor aging monitoring provides greater process reliability
- Easy integration of measurement and diagnostics data from the sensor up to the process control level
- Advanced diagnostic settings for efficient and reliable plant management

The M800 Profinet and Ethernet/IP multi-parameter transmitters bring the value of Intelligent Sensor Management technology to industrial Ethernet. They cover ISM sensors for pH/ORP, conductivity, optical DO, amperometric oxygen (DO as well as O₂ gas), dissolved carbon dioxide, and turbidity, and provide all ISM measurements and diagnostics information to a centralized control system for data management including predictive diagnostics. Both M800 Profinet and Ethernet/IP series provide 1-channel and 2-channel models.

Besides the intuitive operation and alarm management that provided by exist M800, the Profinet and Ethernet/IP communication protocols provide easy integration of sensor diagnostics tools into process control systems, minimum commissioning time and engineering support, saves the integration efforts and costs. Pure digital communication within loop and real-time measurements, sensor diagnostics and monitoring provides greater process reliability, lower maintenance costs.

Profinet and Ethernet/IP Specifications

Data transmission rate	10–100 MBd
Connector	RJ45, M12 optional
IP address	DCP(default) or configuration via menu

M800 Parameter Fit Guide for 2-/4-channel, 1-/2-channel Profinet, 1-/2-channel Ethernet/IP versions

These versions are compatible with the following (digital) ISM sensors.

	Process					
	2-channel ¹⁾	4-channel ¹⁾	1-channel Profinet	2-channel Profinet	1-channel Ethernet/IP	2-channel Ethernet/IP
pH/ORP	•	•	•	•	•	•
pH/pNa	•	•	•	•	•	•
UniCond 2-e/4-e	•	•	•	•	•	•
Conductivity 4-e	•	•	•	•	•	•
Amp. DO ppm/ppb/trace	•/•/• ²⁾	•/•/• ²⁾	•/•/• ²⁾	•/•/• ²⁾	•/•/• ²⁾	•/•/• ²⁾
Amp. O ₂ gas ppm/ppb/trace	•/•/• ²⁾	•/•/• ²⁾	•/•/• ²⁾	•/•/• ²⁾	•/•/• ²⁾	•/•/• ²⁾
Opt. dissolved oxygen	• ²⁾ , 3)	• ²⁾ , 3)	• ²⁾ , 3)	• ²⁾ , 3)	• ²⁾ , 3)	• ²⁾ , 3)
Dissolved carbon dioxide (InPro 5000i)	•	•	•	•	•	•
CO ₂ hi (InPro 5500i)	• ³⁾	• ³⁾	• ³⁾	• ³⁾	• ³⁾	• ³⁾
TOC/Dissolved ozone/Flow	-/-/-	-/-/-	-/-/-	-/-/-	-/-/-	-/-/-
Turbidity	-	-	•	• ⁴⁾	•	• ⁴⁾

1) Process 2-channel and 4-channel models are provided in polycarbonate or stainless steel housing.

2) Ingold sensors.

3) 2-channel: An opt. DO sensor or a CO₂ hi sensor has to be connected to channel 2. 4-channel: opt. DO sensors and CO₂ hi sensors have to be connected to channel 2 and/or to channel 4.

4) Turbidity sensor has to be connected to channel 2 for 2-channel Profinet and 2-channel Ethernet/IP models.

M800 Parameter Fit Guide for 1-channel

This version is compatible with the following (digital) ISM and analog sensors.

	Process ¹⁾	
	Analog	ISM
pH/ORP	•	•
pH/pNa	-	•
UniCond 2-e/UniCond 4-e	-/-	•/•
Conductivity 2-e/Conductivity 4-e	•/•	-/•
Amp. dissolved oxygen ppm/ppb/trace	•/•/• ²⁾	•/•/• ²⁾
Amp. oxygen gas ppm/ppb/trace	•/•/• ²⁾	•/•/• ²⁾
Optical dissolved oxygen	-	• ²⁾
Dissolved carbon dioxide (InPro 5000i)	-	•
CO ₂ hi (InPro 5500i)	-	•
Turbidity	• (backscatter)	•

1) Process models are provided in polycarbonate or stainless steel housing or stainless steel housing. 2) Ingold sensors.

Ordering Information

Transmitters	Order Number
M800 Process 1-channel	30 026 633
M800 Process 2-channel	52 121 813
M800 Process 4-channel	52 121 853
M800 1-channel, stainless steel enclosure	30 246 551
M800 2-channel, stainless steel enclosure	30 246 552
M800 4-channel, stainless steel enclosure	30 246 553
M800 Profinet 1-channel Process	30 530 021
M800 Profinet 2-channel Process	30 530 022
M800 Process 1-channel Ethernet/IP	30 530 023
M800 Process 2-channel Ethernet/IP	30 530 024

Installation Accessories	Order Number
Pipe mounting kit for ½ DIN	30 300 480
Panel mounting kit	52 500 213
Protective hood	30 073 328

Other Highlights

- Pure digital communication within loop and real-time sensor aging monitoring provides greater process reliability
- Easy integration of measurement and diagnostics data from the sensor up to the process control level
- Advanced diagnostic settings for efficient and reliable plant management

M100 DIN Rail: High Performance and Minimal Space Requirement Compact Design for Simplified Installation



The M100 DIN Rail (DR) is a single-channel, 2-wire multi-parameter transmitter with HART communication capability for analytical measurements. It is compatible with ISM sensors for measuring pH/ORP, pH/pNa, oxygen and conductivity. The ISM's Plug and Measure feature minimizes the risk of installation troubles and simplifies sensor handling and LEDs clearly indicate transmitter and sensor status, alarms, and warnings.

Thanks to its compact design the M100 DR requires only a small installation space in the plant.

The transmitter configuration and integration of sensor diagnostics into asset management tools is possible thanks to the integrated HART protocol. The support of all major asset management tools ensures maximum compatibility and easy integration of sensor diagnostics.

Specifications

General

Supply voltage	14 to 30VDC
Number of outputs	1 × 4 to 20 mA (loop powered)
Ambient temperature	- 10 to 60 °C (14 to 140 °F)
Relative humidity	0 to 95 % non-condensing
Enclosure rating	IP 20
Housing material	PA-FR
Hold input	Yes
Analog input	1 × 4 to 20 mA (for pressure compensation)
Communication	HART
Asset management tool compatibility	AMS versions 10, 11, 12, Simatic 6,8x, FDT frame applications

Features Overview

- DIN rail mounting, suitable for 35 mm wide DIN rail systems
- Compact housing, 22.5 mm width
- Displayless
- Multi-parameter transmitter
- 1 analog output (4 to 20 mA with HART)
- HART communication as standard
- Configuration via HART handheld or other HART asset management tools

ISM Highlights

- Plug and Measure functionality
- Dynamic Lifetime Indicator
- Adaptive Calibration Timer
- Time To Maintenance
- CIP/SIP/Autoclaving counter
- Easy installation and fast commissioning

► www.mt.com/M100

M100 Sensor Mount Transmitter: Digital Sensor Integration for Analog and Digital Biocontrollers Smallest Footprint for Simplified Installation



The M100 Sensor Mount (SM) is a single-channel, multi-parameter transmitter. It allows the connection on biocontrollers of 1-wire ISM sensors for measuring pH, ampDO and CO₂ or ISM RS 485 optical oxygen sensors. The M100 SM has a Bluetooth 4.0 interface which is compatible with the PC-based and mobile versions of iSense software. Two independent interfaces are implemented: two configurable 4/20 mA analog outputs and one digital MODBUS RTU. LEDs clearly indicate sensor status, alarms and warnings. ISM's Plug and Measure feature minimizes the risk of installation trouble and simplifies sensor handling.

Specifications

ISM features	Plug and Measure, DLI, ACT, TTM
Enclosure	IP67
Mounting	On head of 1-wire sensor: AK9 On head of RS485 sensor: VP8
Supply voltage	24 VDC
Analog output	Active 2 × 4 to 20 mA, galvanically isolated to passive DCS card
Communication	Wireless: BT 4.0 iSense PC-based and iSense mobile (Android, iOS) Wired: Digital interface RS485 MODBUS RTU
Sensor compatibility	ISM 1-wire pH, amperometric DO and carbon dioxide sensors. ISM RS485 optical DO sensors

Features Overview

- Configurable alarms
- Device naming
- MODBUS communication
- ISM functionality
- Multi-parameter unit
- Configuration via iSense/iSense Mobile
- Process calibration with iSense/iSense mobile or MODBUS
- Color LED indication of sensor status
- Intuitive operation with iSense
- iMonitor

Other Highlights

- CIP/SIP counter
- Dynamic Lifetime Indicator
- Adaptive Calibration Timer
- Easy installation
- Error-free operation: configuration stored in transmitter
- Electronic Data Management with iSense

M80 Sensor Mount Transmitter

ISM Solution for Benchtop Controllers



The M80 Sensor Mount (SM) Transmitter is a compact single-channel, multi-parameter transmitter designed especially for biocontroller manufacturers. Its small footprint allows mounting on ISM sensors used in benchtop bioreactors with a typical volume of 1–20 liters. A MODBUS RTU interface enables straightforward and digital integration of sensor measurement data, ISM diagnostic information, and calibration routines into the biocontroller firmware. In addition, visualization of ISM features on the controller’s graphical user interface becomes possible. The M80 SM is compatible with METTLER TOLEDO pH/ORP, amperometric dissolved oxygen, dissolved CO₂, and conductivity sensors.

Specifications

ISM	Plug and Measure, DLI, ACT, TTM
Power supply	24 VDC (min. 100 mA), 8–30 VDC (min. 2 W)
Operating temperature	–15 to +60 °C (5 to 140 °F)
Relative humidity	5 ... 95 % rH (non-condensing)
Mounting	AK9 connector on head of 1-wire sensor
Cable connection	M12/5-pin for RS485 interface and power supply
Communication	MODBUS RTU protocol
Dimensions	Height: 94 mm (3.7"), Maximum diameter: 22 mm (0.87")
Protection class	IP65

Features Overview

- Small footprint on bioreactor head plate
- Enables ISM functionality in biocontroller software
- Access to sensor calibration routines via the biocontroller
- No sensor configuration necessary due to internal storage of installation point specific data (MODBUS parameters)
- Trouble-free sensor integration thanks to Plug and Measure
- Configurable with M80 SM Transmitter Configuration Tool PC software and Transmitter Configuration Box

Other Highlights

- Robust digital sensor integration
- Ideal for ISM solutions in R&D environment and down-scaling applications
- Pre-batch sensor diagnostics for more robust processes
- Enables electronic traceability of sensors used in different batches
- Less electronic waste compared to pH sensors with permanently integrated transmitter electronics



Parameter Fit Guide

Parameter	M100 DR	M100 SM 1-wire	M100 SM RS 485	M80 SM
pH/ORP	•	•	–	•
pH/pNa	•	•	–	–
Conductivity 4-e	•	–	–	•
Amp. DO ppm/ppb/trace	•/•/•	•/•/•	–	•/–/–
Opt. DO ppm	–	–	•	–
Amp. O ₂ gas ppm	–	–	–	–
Dissolved carbon dioxide	–	•	–	•

Ordering Information

Transmitter	Order Number
M100 DR/2H, 1-channel multi-parameter	30 127 720
M100 SM, 1-wire	30 365 366
M100 SM, RS485	30 365 367
M80 SM Transmitter	30 530 566

Accessories	Order Number
iSense	30 130 614
iSense CFR	30 283 620
iSense dongle	30 371 387
iLink Multi	30 130 631
iLink Multi cable/set oDO (RS485)	30 355 582
M100SM adapter and power supply	30 404 002
CalBox (upgraded with temperature sensor)	52 300 400
Transmitter Configuration Box (cable set included) (M80)	30 530 567
5-pin data cable 2 m (6.6 ft)	52 300 379
5-pin data cable 5 m (16.4 ft)	52 300 380
5-pin data cable 10 m (32.8 ft)	52 300 381

M400 2-Wire: Reliable and Intelligent For Hazardous and Non-Hazardous Area Applications



The M400 2-wire, single-channel, multi-parameter transmitter for pH/ORP, dissolved oxygen, gas phase oxygen, conductivity and dissolved carbon dioxide provides highest reliability and process safety in hazardous and non-hazardous area environments. Advanced ISM functionality enables predictive maintenance resulting in reduced operating costs and helps to improve productivity. The HART, FOUNDATION fieldbus (FF) or PROFIBUS PA interface provides easy integration of sensor diagnostics tools into process control systems.

Specifications

General

Display	Backlit LCD, 4 lines
Languages	8 (English, German, French, Italian, Spanish, Portuguese, Russian and Japanese)
Ambient temperature	-20 to 60 °C (-4 to 140 °F)
Relative humidity	0 to 95 % non-condensing
Enclosure rating	IP 66/NEMA 4X
Housing material	Aluminum die cast

Certificates and Approvals

M400/2H:	FM cFmus Cl.I Div.2
M400(G)/2XH:	ATEX/IECEx Zone 1, FM cFmus Cl.I Div.1 NEPSI Ex Zone 1, TIIS, KCS
M400FF:	ATEX/IECEx Zone 1, FM cFmus Cl.I Div.1 NEPSI Ex Zone 1
M400PA:	ATEX/IECEx Zone 1, FM cFmus Cl.I Div.1 NEPSI Ex Zone 1

PID process controller	Yes (except M400 PA/FF/2XH Type 1)
Analog input	Yes (except M400 2XH Cond Ind/2XH Type 1)

4 to 20 mA with HART

Power voltage	14 to 30VDC
Number of outputs	2 x 4 to 20mA (loop powered)
Hold input	Yes
Alarm contact	Yes (alarm delay 0 to 999 s)
Asset management tool compatibility	AMS versions 10 and 11, Simatic PDM version 6/8, FDT frame applications

Fieldbus Interface

Current	22 mA
Max. current in case of fault (FDE)	<28 mA
Number of current inputs	1 for pressure compensation
Supply voltage	Non-hazardous area (Non-IS): 9 to 32VDC Linear Barrier: 9 to 24VDC FISCO: 9 to 17.5VDC

PROFIBUS PA

Physical interface	According to ICE 61 158-2
Profile	PROFIBUS PA 3.02
ITK version	6.0.1

FOUNDATION fieldbus

Profile	FF_H1
---------	-------

Features Overview

- NEPSI Ex/ATEX/FM approved
- Mixed-mode input (analog or ISM sensors accepted)
- Multi-parameter unit
- 4 to 20mA (with HART) or FOUNDATION fieldbus version or PROFIBUS PA
- Compatible with ODO sensors
- IP 66/NEMA 4X rated

Other Highlights

- Plug and Measure functionality
- CIP/SIP/Autoclaving counter
- Dynamic Lifetime Indicator
- Adaptive Calibration Timer
- Quick set up mode for fast installation

► www.mt.com/M400-2wire

Parameter Specifications**pH, pH/pNa and ISFET Performance**

Measurement parameters	pH, mV, and temperature
pH, ORP input range*	-1500 to 1500 mV
pH display range	-2 to 16 pH
Resolution	0.001/0.01/0.1/1 (can be selected)
Relative accuracy	±0.02 pH; ±1 mV
Temperature input	Pt 1000, Pt 100, NTC 22 kΩ
Temperature compensation	Automatic/manual
Temperature measuring range	-30 to 130 °C (-22 to 266 °F)
Temperature resolution	0.001/0.01/0.1/1 °C/°F (can be selected)
Temperature measurement error*	±0.25 °C (±0.45 °F)
Max. length sensor cable	analog: 20 m (65 ft), depending on sensor; ISM 80 m (260 ft)
Calibration	1 or 2 point calibration, process calibration

* For analog input signal (ISM input signal causes no additional error)

Oxygen Performance

Measurement parameters	- Dissolved oxygen: Saturation or concentration and temperature - Oxygen in gas: Concentration and temperature
Current range	0 to 7000 nA
Oxygen measuring ranges	- Dissolved oxygen: Saturation 0 to 500 % air, 0 to 200 % O ₂ Concentration 0.1 ppb (µg/L) to 50.00 ppm (mg/L) - In gas: 0 to 9999 ppm O ₂ gas, 0 to 100 Vol-% O ₂
Oxygen accuracy*	
- Dissolved oxygen saturation	±0.5 % of the measured value or ±0.5 % air, whichever is greater. Concentration at high values: ±0.5 % of the measured value or ±0.050 ppm/±0.050 mg/L, whichever is greater. Concentration at low values: ±0.5 % of the measured value or ±0.001 ppm/±0.001 mg/L, whichever is greater.
- In gas:	±0.5 % of the measured value or ±5 ppb, whichever is greater for ppm O ₂ gas. ±0.5 % of the measured value or ±0.01 %, whichever is greater for Vol-% O ₂ .
Resolution current	6 pA
Polarization voltage	- 1000 to 0 mV for analog sensors - 550 mV or - 674 for ISM sensors (configurable)
Temperature input	Pt 1000
Temperature compensation	Automatic
Temperature measuring range	-30 to 150 °C (-22 to 302 °F)
Temperature accuracy*	±0.25 K in the range of -10 to +80 °C (14 to +176 °F)
Max. length sensor cable	analog: 20 m (65 ft); ISM 80 m (260 ft)
Calibration	1-point (slope or offset) calibration, process calibration (slope or offset) calibration

* For analog input signal (ISM input signal causes no additional error)

Conductivity Performance

Measurement parameters	Conductivity, and temperature
Conductivity ranges (2-e/4-e)	2-electrode sensor: 0.02 to 2000 µS/cm (500 Ω × cm to 50 MΩ × cm) 4-electrode sensor: 0.01 to 650 mS/cm (1.54 Ω × cm to 0.1 MΩ × cm)
Temperature input	Pt 1000
Temperature measuring range	-40 to 200 °C (-40 to 392 °F)
Max. length sensor cable	60 m (196.9 ft) with 2-electrode sensor, 15 m (50 ft) with 4-electrode sensor 80 m (260 ft) with ISM sensor
Cond/Res accuracy*	±0.5 % of reading or 0.25 Ω, whichever is greater, up to 18 MΩ × cm
Cond/Res repeatability*	±0.25 % of reading or 0.25 Ω, whichever is greater
Cond/Res resolution	0.001/0.01/0.1/1 (can be selected)
Temperature resolution	0.001/0.01/0.1/1 °C/°F (can be selected)
Temperature accuracy*	±0.25 °C (±0.45 °F)
Temperature repeatability*	±0.13 °C (±0.23 °F)
Chemical concentration curves	NaCl, NaOH, HCl, HNO ₃ , H ₂ SO ₄ , H ₃ PO ₄ User-defined concentration table (5 × 5 matrix) TDS ranges NaCl, CaCO ₃
Calibration	1 or 2 point calibration, process calibration

* For analog input signal (ISM input signal causes no additional error)

Parameter Specifications (continued)

Optical Oxygen Performance

Measurement parameters	DO saturation or concentration and temperature
DO saturation range	0 to 500%, 0 to 100% O ₂
DO resolution	Auto/0.001/0.01/0.1/1 (can be selected)
DO accuracy	± 1 digit
Temperature resolution	Auto/0.001/0.01/0.1/1 °C (°F) (can be selected)
Temperature accuracy	± 1 digit
Temperature compensation	Automatic
Max. length sensor cable	15 m (50ft)
Calibration	1 point (depending on sensor model), 2 point, process calibration

Dissolved Carbon Dioxide Performance

Measurement parameters	Dissolved carbon dioxide and temperature
Dissolved carbon dioxide range	0 to 5000 mg/L, 0 to 200% sat, 0 to 1500 mmHg, 0 to 2000 mbar, 0 to 2000 hPa
mV range	-1500 to 1500 mV
Total pressure range	0 to 4000 mbar
Dissolved carbon dioxide accuracy	± 1 digit
Resolution	Auto/0.001/0.01/0.1/1 (can be selected)
Temperature range	-30 to 150 °C (-22 to 302 °F)
Temperature resolution	Auto/0.001/0.01/0.1/1 °C/°F (can be selected)
Temperature accuracy	± 1 digit
Temperature repeatability	± 1 digit
Max. length sensor cable	80 m (260ft)
Calibration	1 or 2 point calibration, process calibration

Inductive Conductivity (M400 Cond Ind transmitter only)

Measurement parameters	Conductivity and temperature
Display range	0 to 2,000 mS/cm
Chemical concentration curves	NaCl: 0-26% @ 0°C to 0-28% @ +100°C NaOH-1: 0-13% @ 0°C to 0-24% @ +100°C NaOH-3: 15-50% @ 0°C to 35-50% @ +100°C HCl-1: 0-18% @ -20°C to +50°C HCl-2: 22-39% @ -20°C to +50°C HNO ₃ -1: 0-30% @ -20°C to +50°C HNO ₃ -2: 35-96% @ -20°C to +50°C H ₂ SO ₄ -1: 0-26% @ -12°C to 0-37% @ +100°C H ₂ SO ₄ -2: 28-88% @ 0°C to 39-88% @ +95°C H ₂ SO ₄ -3: 94-99% @ -12°C to 89-99% @ +95°C H ₃ PO ₄ : 0-35% @ +5°C to +80°C User-defined concentration table (5 × 5 matrix)
TDS ranges	NaCl, CaCO ₃
Conductivity accuracy	± 1.0% of reading or ± 0.005 mS/cm
Conductivity repeatability	± 1.0% of reading or ± 0.005 mS/cm
Conductivity resolution	Auto/0.001/0.01/0.1/1 (can be selected)
Temperature input	PT1000/PT100/NTC22K
Temperature measuring range	-40 to +200 °C (-40 to +392 °F)
Temperature resolution	Auto/0.001/0.01/0.1/1 (can be selected)
Temperature accuracy	± 0.25 K (± 0.45 °F) within -30 to +150 °C (-22 to +302 °F); ± 0.50 K (± 0.90 °F) outside
Temperature repeatability	± 0.13 K (± 0.23 °F)
Max. sensor cable length	10 m (32.8 ft)
Calibration	1-point, zero point or process

Ordering Information

Transmitter	Order Number
M400/2H, 1-channel multi-parameter	30 025 514
M400/2XH, 1-channel multi-parameter	30 025 515
M400/2XH 1-channel Cond Ind	30 256 307
M400G/2XH, 1-channel multi-parameter	30 025 516
M400FF, 1-channel multi-parameter	30 026 616
M400PA, 1-channel multi-parameter	30 026 617
M400/2XH Type 1, 1-channel multi-parameter	30 256 317

Accessories

Accessories	Order Number
Pipe mounting kit for ½ DIN	30 300 480
Panel mounting kit for ½ DIN	52 500 213
Protective hood	52 500 214

Transmitter Fit Guide

Parameter	M400/2(X)H		M400/2XH Cond Ind	M400/2XH Type 1		M400G/2XH		M400FF		M400PA	
	Analog	ISM	Analog	Analog	ISM	Analog	ISM	Analog	ISM	Analog	ISM
pH/ORP	•	•	–	•	•	•	•	•	•	•	•
Conductivity 2-e	•	–	–	–	–	•	–	•	–	•	–
Conductivity 4-e	•	•	–	•***	–	•	•	•	•**	•	•**
Amp. DO* ppm/ppb/trace	•/•/•	•/•/•	–	–	–	•/•/•	•/•/•	•/•/•	•/•/•	•/•/•	•/•/•
Amp. O ₂ gas	–	–	–	–	–	•	•	•	•	•	•
Optical oxygen ppm/ppb	–	•/•	–	–	–	–	•/•	–	•/•	–	•/•
Dissolved carbon dioxide (low)	–	•	–	–	–	–	•	–	•	–	•
Inductive conductivity	–	–	•	–	–	–	–	–	–	–	–

* Ingold and Thornton sensors

** Ingold sensors

*** Analog only

iSense

Maximum Performance of ISM Sensors



ISM®

**21 CFR Part 11
& Annex 11 ready**

iSense CFR is technically compliant with 21 CFR Part 11 and EudraLex Volume 4 Annex 11.

iSense offers a unique means to optimize the performance of pH electrodes, oxygen and carbon dioxide sensors for enhanced reliability and process safety. Simply connect your ISM sensor via USB or Bluetooth to your PC and get access to various intuitive analysis, calibration and documentation applications. Pre-calibrate your ISM sensor with the accuracy of lab conditions and assess the sensor state with real-time diagnostic information. This allows you to decide instantly whether to re-use or discard a sensor. Calibration information is collected, managed and analyzed efficiently and documented consistently to satisfy regulatory requirements.

Specifications

Performance	
Measurement parameters	pH/ORP all digital ISM sensors Oxygen all digital ISM sensors CO₂ InPro 5000i
pH calibration	1-point, 2-point, 3-point, process
ORP calibration	1-point, process
DO calibration for amp. sensors	1-point, process
DO calibration for optical sensors	1-point, 2-point, scaling
CO ₂ (InPro 5000i) calibration	1-point, 2-point, process
M100 SM settings	Yes
Sensor field calibration dataset	Yes
Sensor database	Yes
Database backup	Yes
Key performance indicators (KPI)	Yes
Recommended PC requirements	
Processor	iCore™
RAM	4 GB
Screen resolution	1280 × 1024 or higher
Hard disk	250 M B available space
Operating system	MS-Windows 7/8/8.10 (at least XP SP3 or later)
Interface	USB and/or Bluetooth™ (depending on the accessory)

Features Overview

- Automatic PDF protocols with sensor registration/calibration/adjustments/deactivation
- Protocols of field calibration
- Full sensor history
- Database export for further analysis

Other Highlights

- Intuitive Windows™ interface
- Early detection of worn-out sensors
- Comprehensive, at a glance sensor status analysis

► www.mt.com/iSense

Ordering Information

Description	Order Number
iSense	30 130 614
iSense CFR	30 283 620

Accessories	Order Number
iLink Multi (with integrated barometer and hygrometer)	30 130 631
iLink Multi Cable/Set oDO (RS485) (required cable set for optical oxygen sensors connecting with iLink Multi)	30 355 582
AK9/1m/BNC-50 (required cable set for pH, CO ₂ and amperometric oxygen sensors connecting with iLink Multi)	59 902 168
CalBox with temperature sensor for iLink Multi	52 300 400
iSense BT Dongle (wireless connection to M100 SM and J-Box BT)	30 371 387
Cable DS AK9-RJ12 (connects 1-wire sensors to iSense)	52 300 383
*iLink RS485 VP	30 014 134
*iLink RS485	52 300 399

* For Optical Dissolved Oxygen Sensors



iLink Multi is a universal device for connecting digital ISM sensors (1-wire; RS485) to a PC/laptop running iSense software. When calibrating an optical DO sensor with the iLink Multi, calibration parameters are captured automatically using the built-in, physical parameter sensors.



Did You Know

iSense Mobile allows you to check sensor status or conduct calibrations from the convenience of your phone. Download is free at Google Play or iTunes.

► www.mt.com/ism-accessories

Learn more about iSense, iSense Mobile and its accessories.

Verification Kits

Simulating Sensors and Validating Transmitters



The pH, O₂ and the CO₂ Verification Kits are sets of five different service tools that allow the simulation of reading values of pH, O₂ and the CO₂ ISM sensors with predefined measuring values and errors (not changeable by the user). Each tool corresponds to a METTLER TOLEDO ISM sensor and delivers a complete set of data information. They can also be used for control of loop and transmitter settings, as control of the transmitter's temperature compensation and general troubleshooting. Each verification kit is provided with a certificate.

Specifications

ISM Verification Kits

ISM Simulator pH Kit	pH 4, pH 7, toggle, ERR1, ERR2
ISM Simulator O ₂ (InPro 6850i) Kit	Zero, Air, toggle, ERR1, ERR2
ISM Simulator O ₂ ppb (InPro 6900i/InPro 6950i) Kit	Zero, Air, toggle, ERR1, ERR2
ISM Simulator CO ₂ (InPro 5000i) Kit	15 mbar, 950mbar, toggle, ERR1, ERR2
Optical O ₂ (InPro 6860i, InPro 6870i, InPro 6960i, InPro 6970i, THO ODO) Simulator	Zero, Air 1, Air 2, toggle, ERR1, ERR2

pH Analog Verification Kits

pH Simulator 112	pH 4, pH 7, pH 9
VP Simulator	20 °C (Pt100 or Pt1000), 50 °C (Pt100 or Pt1000)

Certificates and Approvals

ISM pH	IECEX/ATEX Ex ia IIC T6/T5/T4/T3 Ga/Gb FM: IS/I,II,III/1/ABCDEFG/T6
Amperometric O ₂	IECEX/ATEX Ex ia IIC T6/T5/T4/T3 Ga/Gb IECEX/ATEX Ex ia IIIC T69 °C/T81 °C/T109 °C/ T161 °C Da/Db FM: IS/I,II,III/1/ABCDEFG/T6

Features Overview

- Tool for verification of a measuring system
- Service tool for quick checks
- Control of transmitter settings
- Troubleshooting

Ordering Information

ISM Verification Kits	Order Number
ISM Simulator pH Kit	52 300 410
ISM Simulator O ₂ (InPro 6850 i) Kit	52 300 416
ISM Simulator O ₂ ppb (InPro 6900 i) Kit	52 300 422
ISM Simulator O ₂ Trace (InPro 6950 i) Kit	52 300 428
ISM Simulator CO ₂ (InPro 5000 i) Kit	30 031 035
Optical O ₂ (InPro 6860 i, InPro 6870 i, InPro 6960 i, InPro 6970 i, THO ODO) Simulator	30 404 694

pH Analog Verification Kits	Order Number
pH Simulator 112	59 906 431
VP Simulator	52 120 939

Did You Know
 The ISM pH, oxygen and CO₂ service tools are unique products that can control and verify loop and transmitter settings. The simulators generate a comprehensive data-set of non-modifiable ISM parameters.



Optical O₂ Simulator



pH Analog Verification Kits: Combining the pH simulator 112 ① with the VP simulator ② both pH and Temperature signals can be simulated to check the automatic temperature compensation capability of the transmitter.

Process Connection Hardware Solutions for Every Challenge

METTLER TOLEDO Ingold offers a comprehensive line of products to connect to all common process environments – open basins, pipes, closed tanks, chemical reactors, bioreactors, and fermentation vessels. Depending upon the application, each connection type can have specific requirements for strength, safety, cleanliness, optimized performance, corrosion resistance, insertion depth, or physical space. Process connection hardware ranges from simple drop-in immersion fittings to complex automated systems capable of cleaning and calibrating your measuring equipment. The choice is yours! METTLER TOLEDO Ingold and your local representatives have worked extensively with a wide variety of process environments and can assist you in selecting the best hardware for your application.

The primary considerations when selecting a housing are:

1. Stationary or retractable housing
2. Connection entry: top-entry, side-entry, etc. (see illustration)
3. Connection style: cap nut, threaded NPT, etc.
4. Diameter of connection hole (bore size)
5. Insertion length
6. Wetted part materials: stainless steel, PVC, etc.
7. Process seal material (O-rings/gaskets)

This section has been organized according to the seven requirements listed above. To simplify selection, first decide if you prefer stationary,

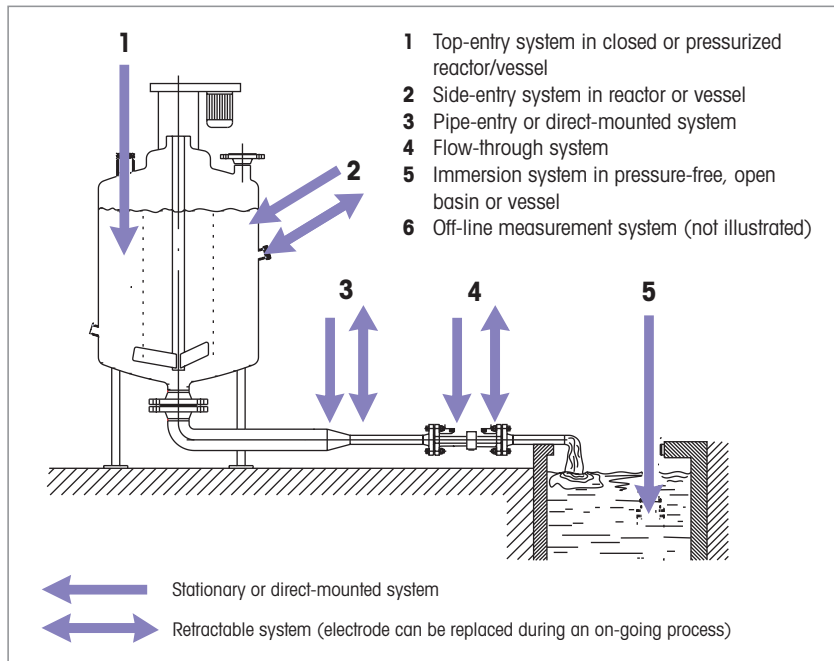

Common Entry/Style	Threaded Cap Nut	Threaded NPT	ANSI/DIN Flange	Ladish (Tri-Clamp)	Tuchenhagen/Varivent
1 Top-Entry	•	•	•	•	–
2 Side-Entry	•	•	•	•	•
3 Pipe-Entry	•	•	•	–	–
4 Flow-Through	•	•	•	–	–
5 Immersion	–	–	–	–	–

Common Wetted Parts	Key	Common O-rings	Key
Stainless Steel 316L	SS 316L	EPDM FDA Listed	EP
Stainless Steel 316L with Electropolish	SS E-P	EPDM Peroxide Cured	EP-pc
Stainless Steel 316L with Machined Surface	R _a XX	Kalrez® FDA Listed USP Class VI	Ka-FDA-USP VI
Hastelloy	HA-C22	Silicone FDA Listed USP Class VI	Si-FDA-USP VI
Titanium	Ti	Silicone Peroxide Cured	Si-pc
PVC	PVC	PTFE/PTFE Coated*	N/A
PVDF	PVDF	Viton® FDA Listed	Vi
PTFE	PTFE	* As tested PTFE materials failed to provide acceptable elastomeric sealing and are not recommended.	

retractable, or flow through design and turn to the corresponding section that follows. A variety of different housings are available in each section

to meet your specific entry-type, connection style, and other requirements.

The Ingold Socket and Safety Socket

Recognizing the need for a strong, sanitary, and safe process connection, Ingold engineered a socket to exceed the requirements found in the most demanding process environments.



When used with an appropriate housing, the Ingold Safety Socket allows the housing O-ring to break its seal while the cap nut retains a safe thread engagement. (See diagram below).

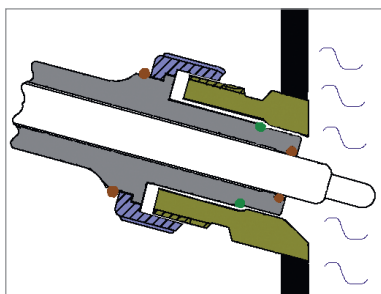

Retractable housings:

- **Secure**
- **Self-cleaning**
- **Process-independent**
- **Manual or automated**
- **Insertion lock without sensor**
- **For use in hazardous areas (ATEX, FM certificates)**

Ingold housings

The hardware used to connect your analytical system to your process is now more important than ever and can actually improve your overall operating efficiency.

Retractable housings, first pioneered by METTLER TOLEDO Ingold, have now evolved into highly-sophisticated components which are process-independent, making sensor maintenance possible at any time without interrupting your process. Pneumatically operated housings insert and retract sensors automatically and form the cornerstone of a fully autonomous analytical system, capable of unattended cleaning and calibration. With an automated system your highly-skilled maintenance staff is able to focus on critical maintenance and repair projects rather than cleaning and calibrating sensors, raising the efficiency and productivity of your operation. For more information on automated maintenance systems, see page 136.

Stationary housings are widely used in all industries, providing a secure, durable, and safe way to position sensing devices in a process. Once connected, however, the stationary housing and sensor must be left in place until the process stops or flow is interrupted and the tank/pipe is drained.

Wide range of process connections

Only a representative sample of Ingold's extensive process connection products are included in this catalog. Please refer to the METTLER TOLEDO product literature for more information.

Don't see exactly what you need?

METTLER TOLEDO Ingold has more than 50 years of experience engineering specialized components or altering existing products to meet specific project requirements. Whether your need is for process resistant metals, special finishes, or modified dimensions, challenge us – chances are we have already designed what you need.

Looking for a non-standard connection?

A growing number of projects co-locate redundant production facilities around the globe, occasionally standardizing process connections. METTLER TOLEDO Ingold is an international company, working with clients world-wide to equip state-of-the-art processing facilities with liquid analytical systems. If your project requires special process connections, we can help.

Sockets, Flanges, and Plugs

Reliable Adaption to the Process

Weld-in Sockets and Flanges



Ingold Socket and Safety Socket (DN25 and DN25/S)

The new safety weld-in sockets provide increased protection in the event of any premature attempt to remove the housing when the reactor or pipe is still under pressure or filled with medium. The socket is designed to prevent possible injury, damage or loss of medium. The Ingold Safety Socket is EHEDG approved.

Safety Feature:

- InFit 761-NC
- InFit 764-50-NC
- InPro 68xx

No Safety Feature:

- All previous types of housings or 25 mm DO sensors can be used, but without the benefit of the safety feature.



Specifications

Wetted Parts	Finish	Pressure Rating
Stainless 316 L	N6/R _a 32 (R _a =0.8 μm/32 μin)	16 bar (232 psi)

Screw-in Sockets



Primarily used for 19 mm vessel and pipe mounting applications.

Specifications

Wetted Parts	Finish
Stainless 316 L	N6/R _a 32 (R _a =0.8 μm/32 μin)

Blind Plugs



Manufactured to exacting standards to seal unused weld-in sockets and ports during cleaning and general operation.

Specifications

Wetted Parts	Finish
Stainless 316 L	N6/R _a 32 (R _a =0.8 μm/32 μin)

Ordering Information

Ingold Sockets	Bore Size	Insertion Length	Angle	Order Number
Ingold socket, weld-in	25 mm	40 mm	15°	59 901 124
Ingold socket, weld-in	25 mm	40 mm	0°	59 901 127
Ingold socket, weld-in	25 mm	48 mm	15°	59 901 125
Ingold socket, weld-in	25 mm	50 mm	0°	59 901 128
Ingold socket, weld-in	25 mm	55 mm	15°	59 901 126
Ingold socket, weld-in	25 mm	60 mm	0°	59 901 129
OPTIONS: R _a finish, electro-polish, non-reactive materials, other				Contact METTLER TOLEDO

Ingold Safety Sockets	Bore Size	Insertion Length	Angle	Order Number
Ingold safety socket, DN25/S weld-in	25 mm	40 mm	15°	52 400 462
Ingold safety socket, DN25/S weld-in	25 mm	47 mm	0°	52 400 518
OPTIONS: R _a finish, electro-polish, non-reactive materials, other				Contact METTLER TOLEDO

Screw-in Sockets	Bore Size	Insertion Length	Angle	Order Number
Screw-in socket	19 mm	40 mm	0°	59 901 290

Blind Plugs	Connect	Bore Size	Insertion Length	Wetted Parts	Order Number
BSP socket plug, straight	2¾" BSP	25 mm	50 mm	Stainless 316L	59 900 903
Ingold socket plug, straight DN25	Ingold	19 mm	42 mm	Stainless 316L	59 901 294
Ingold socket plug, straight DN25	Ingold	25 mm	40 mm	Stainless 316L	59 901 287
Ingold socket plug, 15° DN25	Ingold	25 mm	40 mm	Stainless 316L	59 901 283
Ingold socket plug, 15° DN25	Ingold	25 mm	48 mm	Stainless 316L	59 901 284
Ingold socket plug, straight DN25	Ingold	25 mm	50 mm	Stainless 316L	59 901 288
Ingold socket plug, 15° DN25	Ingold	25 mm	55 mm	Stainless 316L	59 901 285
Ingold socket plug, straight DN25	Ingold	25 mm	60 mm	Stainless 316L	59 901 289
OPTIONS: R _a finish, electro-polish, non-reactive materials, O-rings, process connection, other					Contact METTLER TOLEDO

InFit 761 e

High Versatility with a Wide Selection of Process Connections



The InFit 761 e series housings are stationary housings for 12 mm sensors with a Pg 13.5 threaded collar. This is one of the most versatile housings in the Ingold product line due to the wide availability of materials, O-rings, process connections, and insertion lengths. Rugged plastic (PVDF, PP), stainless steel, and Hastelloy (optional) versions stand up to harsh and demanding environments encountered in industrial processing and industrial wastewater applications. For extreme hygienic requirements, the InFit 761 e is available in 316L stainless steel configurations (EHEDG and 3A compliant), and also with N5/R_a 16 surface finishes to meet the most stringent regulatory guidelines.

Specifications

	InFit 761 e, Steel Version	InFit 761 e, Plastic Version
Wetted parts	Stainless 316L	PVDF, PP
Surface finish (O-ring groove/Other)	N5/N5 (R _a 16/R _a 16)*	N6/N7 (R _a 32/R _a 63)
O-ring***	Silicone-FDA-USP VI	Viton®-FDA
Sensor fitting	Pg 13.5	Pg 13.5
Temperature range	0–140°C/32–284°F	0–100°C/32–212°F
Pressure rating (Sensor dependent)	Max. 16 bar/232 psig	Max. 6 bar/87 psig**
Certificates and Approvals	EHEDG and 3A compliant (CIP shaft only) ATEX/FM certificates (metallic version only): Pressure Equipment Directive guidelines (PED) and CE	

* Not with protective cage

** Temperature dependent

*** Other O-ring material see technical document

Many housing options are available. Please use the product configurator and sensor fit guide found on p. 115.

Suggested Sensors

pH	DO	CO ₂	Conductivity	Turbidity
InPro 3030	InPro 6050	InPro 5000 (i)	InPro 7001	InPro 8050
InPro 3100 (i)	InPro 6800 (G)		InPro 7100 (i)	InPro 8100
InPro 3250 (i)	InPro 6850 i (G)			InPro 8200
InPro 4010	InPro 6900 (i) (G)			
InPro 4260 (i)/4281 i	InPro 6950 (i) (G)			
InPro 4800 (i)/4881 i	InPro 6860 i* /6970 i*			
DPAS, DPA				
DXK				

* special Retrofit Kit required

Other Highlights

- Simple, yet highly durable
- Easy-to-use and low maintenance

Features Overview

- Models with sensor holder type "C" integrate with the Ingold safety socket to prevent injury or damage

- Many options for corrosion-resistant materials, O-rings, and process connections
- Surface finish N5/R_a 16 (excluding version with protective cage)

► www.mt.com/InFit761



InFit 764 e

Problem Solver in Combination with Liquid-filled pH Electrodes



The InFit 764 e housings are specifically designed to maximize the performance and longevity of liquid-filled pH and redox sensors. The body of the housing can be pressurized to maintain a positive pressure differential between the sensor fill solution and the process. The positive differential eliminates sensor contamination by preventing process media from crossing the diaphragm into the sensor. A large inspection window makes it easy to monitor electrolyte level.

Specifications

	InFit 764 e, Steel Version	InFit 764 e, Plastic Version
Wetted parts	Stainless 316L	PVDF
Surface finish (O-ring groove/Other)	N5/N5 (R _a 16/R _a 16) *	N6/N6 (R _a 32/R _a 32)
O-ring ***	Silicone-FDA-USP VI	Silicone-FDA-USP VI
Sensor fitting	Liquid-filled electrodes	Liquid-filled electrodes
Temperature range	0–130 °C/32–266 °F	0–110 °C/32–230 °F
Pressure rating (Sensor dependent)	0–6 bar/0–87 psig	0–6 bar/0–87 psig **

Certificates ATEX/FM certificates (metallic version only):

and Approvals Pressure Equipment Directive guidelines (PED) and CE

* Not with protective cage

** Temperature dependent

*** For other O-ring material see technical documentation

Many housing options are available. Please use the product configurator found on p. 115.

Suggested Sensors

pH	DO	CO ₂	Conductivity	Turbidity
InPro 2000 (i)	N/A	N/A	N/A	N/A

Sensor Fit Guide (for Liquid-Filled Electrodes)

Sensor Length	Insertion Length			
	70mm	100mm	150mm	200mm
120mm	•	–	–	–
150mm	–	•	–	–
200mm	–	–	•	–
250mm	–	–	–	•

The InFit 764 e housing is specifically designed for use with liquid-filled pH sensors. This sensor fit guide is designed to assist you with selecting the proper pH sensor. Other insertion lengths are available on request.

Other Highlights

- 3A compliant (CIP shaft only)

Features Overview

- Positive overpressure
- Large inspection window
- Sterilizable in situ
- Surface finish N5/R_a 16 (excluding version with protective cage)



Stationary Housings

Flexible Multi-Parameter Control

Ordering Information

InFit 761 e for 12 mm Sensors	Process Connect	Bore Size	Insertion Length	Wetted Parts	Order Number
InFit 761 e/NC/0070/4435/T01/Si--	TC 1.5"	25 mm	70 mm	SS	52 400 494
InFit 761 e/NC/0070/4435/T02/Si--	TC 2"	25 mm	70 mm	SS	52 400 495
InFit 761 e/NC/0033/4435/V02/Si--	Varivent	25 mm	33 mm	SS	52 400 502
InFit 761 e/NC/0070/4435/D00/Si9-	DN25	25 mm	70 mm	SS	52 400 491
InFit 761 e/NS/0070/4435/D00/Si9-	DN25	25 mm	70 mm	SS	59 900 796
InFit 761 e/NS/0175/4435/D00/Si9-	DN25	25 mm	175 mm	SS	59 900 797
InFit 761 e/WS/0070/4435/D10/Vi2-	DN25	25 mm	70 mm	SS	59 900 753
InFit 761 e/WS/0100/4435/D00/Si9-	DN25	25 mm	100 mm	SS	59 900 792
InFit 761 e/WS/0175/4435/D00/Si9-	DN25	25 mm	175 mm	SS	59 900 779
InFit 761 e/WS/0070/4435/D00/Si9-	DN25	25 mm	70 mm	SS	59 900 754
InFit 761 e/WS/0070/4435/D00/EP9-	DN25	25 mm	70 mm	SS	59 909 163
InFit 761 e/WK/0040/PP--/N04/Vi--	NPT ¾"	25 mm	40 mm	PP	52 403 478
InFit 761 e/NS/0070/PP--/D00/Vi9-	DN25	25 mm	70 mm	PP	52 400 316
InFit 761 e/WK/0040/PVDF/N04/Vi--	NPT ¾"	25 mm	40 mm	PVDF	52 401 520
InFit 761 e/NS/0070/PVDF/D00/Vi9-	DN25	25 mm	70 mm	PVDF	52 400 311

If the housing configuration required is not included in the order number list above, please use the product configurator found on p. 115.

Accessories for InFit 761 e and InFit 764 e Housings

	Order Number
O-ring set/Si/USP/76X	52 403 459
O-ring set/ep/FDA/76X	52 403 460
O-ring set/Vi/FDA/76X	52 403 461
O-ring set/Ka/USP/76X (∅ 25 mm shaft)	52 403 462
O-ring set/Ka/USP/76X (∅ 19 mm shaft)	52 403 504
Retrofit Kit for optical sensors	52 403 811

Sensor Fit Guide (for Glass pH Electrodes)

Sensor Length	Insertion Length								
	25mm	33mm	40mm	70mm	100mm	150mm	175mm	275mm	375mm
120mm	•	•	•	•	–	–	–	–	–
150mm	–	–	–	–	•	–	–	–	–
200mm	–	–	–	–	–	•	–	–	–
225mm	–	–	–	–	–	–	•	–	–
325mm	–	–	–	–	–	–	–	•	–
425mm	–	–	–	–	–	–	–	–	•

The InFit 761 e housing is a universal housing for use with pH, DO, CO₂, conductivity and turbidity sensors. When using glass electrodes, it is important not to expose too much glass beyond the end of the housing. This sensor fit guide is designed to assist you with selecting the proper glass pH sensor. Stainless steel sensors (DO, CO₂, cond, turb) are more rigid and may extend farther beyond the end of the housing, but it is not recommended. Other insertion lengths are available on request.

Product Configurators

InFit 761 e housing: Sensor Fit Guide (for glass pH electrodes)

Sensor Length	Insertion Length								
	25mm	33mm	40mm	70mm	100mm	150mm	175mm	275mm	375mm
120mm	•	•	•	•	–	–	–	–	–
150mm	–	–	–	–	•	–	–	–	–
200mm	–	–	–	–	–	•	–	–	–
225mm	–	–	–	–	–	–	•	–	–
325mm	–	–	–	–	–	–	–	•	–
425mm	–	–	–	–	–	–	–	–	•

The InFit 761 e housing is a universal housing for use with pH, DO, CO₂, conductivity and turbidity sensors. When using glass electrodes, it is important not to expose too much glass beyond the end of the housing. This sensor fit guide is designed to assist you with selecting the proper glass pH sensor. Stainless steel sensors (DO, CO₂, cond, turb) are more rigid and may extend farther beyond the end of the housing, but it is not recommended. Other insertion lengths are available on request.

TL 761 Adapter

Cost-effective replacement



The TL 761 Adapters used in conjunction with any METTLER TOLEDO 120mm pH/ORP sensor are direct replacements for Van London's twist to lock family of electrodes. The TL 761 Adapter provides greater system flexibility by working with both standard and Intelligent Sensor Management (ISM) electrodes. The cost-effective adapters are available in 316 stainless steel or polyvinylidene fluoride (PVDF) wetted material of construction with fluorocarbon (FKM) O-Ring seals.

Specifications

Applications	For use with any METTLER TOLEDO 120mm pH/ORP electrode for direct replacement of Van London twist to lock pH/ORP electrodes
Pressure range*	150 psi
Temperature range*	266°F for SS 176°F for PVDF
Operation	manual, quarter turn operation
Wetted parts	316 stainless steel or PVDF
Wetted o-rings	Fluorocarbon (FKM)
Non-wetted parts	Glass-filled PP
Process connection	Direct connection to Van London twist to lock adapter

*Final system pressure/temperature rating cannot exceed combined adapter and electrode rating

Features Overview

- Cost-effective, direct replacement sensor housing for Van London's twist to lock sensors
- Maximum sensor selection flexibility through compatibility with standard and Intelligent Sensor Management (ISM) pH/ORP electrodes
- Low cost of ownership by limiting consumable element
- Chemically resistant materials of construction

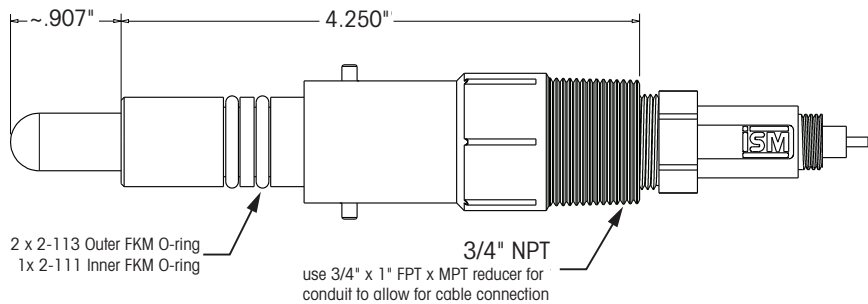

**Did you know?**

The TL 761 Adapter is used with any standard 120mm length pH analog or ISM sensor with Pg 13.5 thread from METTLER TOLEDO for maximum flexibility.

TL 761 Housing

Description	Order Number
TL 761/SS/FKM	53 300 117
TL 761/PVDF/FKM	53 300 116

Recommended electrode selection guide**General purpose pH and ORP electrodes**

Description	Meas. Range	Temp	Temp Comp	Pressure	Cable	Order Number
405-60-PA-S8/120	0-12 pH	32-176°F	No	58 psig	AS9	59 903 081
PI4805-60-PA-S8/120	ORP	32-176°F	No	58 psig	AS9	59 904 143
InPro 4010/120	2-12 pH	32-146°F	No	58 psig	VP	52 000 510
InPro 4010/120/PT100	2-12 pH	32-146°F	RTD PT100	58 psig	VP	52 000 511
InPro 4010/120/PT1000	2-12 pH	32-146°F	RTD PT1000	58 psig	VP	52 000 512

High Performance ISM combination pH and ORP electrodes

Description	pH Range	Temp	Temp Comp	Pressure	Cable	Order Number
InPro 3250i/SG/120	0-14 pH	32-212°F	Yes	58 psig	AK9	52 005 373
InPro 4260i/SG/120	0-14 pH	32-266°F	Yes	217 psig	AK9	52 005 381
InPro 4800i/SG/120	0-14 pH	32-266°F	Yes	174 psig	AK9	52 005 383

Electrode cable

Description	Type	Length*	Order Number
Cable, AS9/5M coax/tinned	AS9	5 meter	59 902 292
Cable, AS9/10M coax/tinned	AS9	10 meter	59 902 318
Cable, AK9/5M coax/tinned	AK9	5 meter	59 902 213
Cable, AK9/10M coax/tinned	AK9	10 meter	59 902 230
Cable, AK9/20M coax/tinned	AK9	20 meter	52 300 204
Cable, VP-ST/5M	VP-6	5 meter	52 300 109
Cable, VP-ST/10M	VP-6	10 meter	52 300 110
Cable, VP-ST/20M	VP-6	20 meter	52 300 141

* Please consult factory for availability of additional cable lengths if required

InFit 762 e/763 e

The Solution for Top-Entry into Large Vessels



InFit 762 e

InFit 763 e



Other Highlight

- Certificates of compliance are available upon request, including certificate of inspection 3.1

► www.mt.com/InFit762

► www.mt.com/InFit763

The InFit 762 e and InFit 763 e stationary housings are designed for top mount applications in larger vessels and reactors. An optional protective cage may be ordered separately. The static insertion housing InFit 762 e allows quick and easy installation of electrodes and sensors with Pg 13.5 thread. This allows the use of a large range of pH/redox electrodes with solid or gel-type reference electrolyte as well as sensors for measuring conductivity, turbidity, dissolved oxygen and CO₂. The static insertion housing InFit 763 e provides quick and easy integration of pressurized pH/redox electrodes with liquid and refillable reference electrolyte. The InFit 763 e (PVDF version) housing is specifically designed for applications where tank damage is of concern – especially glass-lined reactors. The InFit 763 e (PVDF version) housing connects to the process using a variety of available flanges; however, a PN16 (AISI 150) flange is specified most often. A protective cage protects the electrode against abrasive solids in the process medium. The InFit 763 e (PVDF version) is designed for use where stainless steel is unsuitable and/or if the reactor is lined with rubber or glass.

Specifications

	InFit 762 e/763 e, Steel Version	InFit 763 e, Plastic Version
Wetted parts	Stainless 316 L/C22/Ti	PVDF
Surface finish (O-ring groove/Other)	N6/N8 (R _a 32/R _a 125)	N6/N8 (R _a 32/R _a 125)
O-ring**	Viton®-FDA	Viton®-FDA
Sensor fitting	762 e: Pg 13.5 763 e: InPro 2000	InPro 2000/Pg 13.5 (opt.)
Temperature range	0 – 130 °C/32 – 266 °F	0 – 130 °C/32 – 266 °F
Pressure rating (Sensor dependent)	0 – 6 bar/0 – 87 psig	0 – 10 bar/0 – 145 psig*

Certificates ATEX/FM certificates (metallic version only):

and Approvals Pressure Equipment Directive guidelines (PED) and CE

* Temperature dependent ** Other O-ring material see technical documentation

Suggested Sensors

	pH	DO	CO ₂	Conductivity	Turbidity
InFit 762 e	InPro 3030 InPro 3100 (i) InPro 3250 (i) InPro 4260 (i) InPro 4800 (i) DPAS, DPA DXK	InPro 6050 InPro 6800 (G) InPro 6850 (i) (G) InPro 6900 (i) (G) InPro 6950 (i) (G)	N/A	InPro 7001 InPro 7100 (i)	InPro 8050 InPro 8100 InPro 8200
InFit 763 e	InPro 2000 (i)	N/A	N/A	N/A	N/A

Many housing options are available. Please use the product configurator and sensor fit guide found on p. 119.

Features Overview

- Up to 4 m (13.1 ft) insertion length
- Rugged stainless steel or PVDF construction
- Extra long insertion lengths
- Uses cost-effective 120 mm/150 mm sensors

InDip 500 Series Immersion Housing for Open Basin Installations



The InDip™ immersion housings are designed to provide a cost-effective, yet rugged process connection with the flexibility to meet the wide variety of installation requirements found in open tanks, reactors, aeration basins and open vessels.

Specifications

	InDip 550
Wetted parts	PVC, PVDF
Surface finish	N/A
(O-ring groove/Other)	
O-ring	Viton®-FDA
Sensor fitting	Pg 13.5, 1" NPT, ¾" NPT, IND
Temperature range	0–60 °C/32–140 °F (PVC) 0–100 °C/32–212 °F (PVDF)
Pressure rating	N/A
(Sensor dependent)	

Suggested Sensors

pH	DO	CO₂	Conductivity	Turbidity
InPro 3030	InPro 6050	N/A	InPro 7001	InPro 8050
InPro 3100 (i)	InPro 6800 (G)		InPro 7108	InPro 8100
InPro 3250 (i)	InPro 6850 (i) (G)		InPro 7250	
InPro 4010	InPro 6900 (i) (G)		InPro 7100 (i)	
InPro 4260 (i)	InPro 6950 (i) (G)			
InPro 4501				
InPro 4800 (i)				
DPA				
DPAS				
DXK				

Sensor Fit Guide

Sensor Length	Insertion Length
120 mm	User-defined (max. 3 m)

The InDip 550 is designed to accept all 120 mm sensors.

Many housing options are available. Please use the product configurator found on p. 121.

Features Overview

- Watertight
- Choice of materials
- Wide range of installation options
- Automation with EasyClean 100

► www.mt.com/InDip500

Ordering Information

InDip 508 Series	Process Connect	Bore Size	Insertion Length	Wetted Parts	Order Number
InDip 508	N/A	N/A	User Defined	PVC	52 403 525
Indip 508	N/A	N/A	User Defined	PVDF	52 403 526

OPTIONS: Non-reactive materials, O-rings, other

Accessories

ISM extension cable/3m	52 004 018
------------------------	------------

For the housing configuration of the InDip 550, please use the product configurator below.

Please call Ingold at 800-352-8763 for pricing and availability.

Product configurator (InDip 550)

Insertion length			
1000 mm insertion length			
1500 mm insertion length			
2000 mm insertion length			
2500 mm insertion length			
3000 mm insertion length			
Material (wetted parts)			
PVC (polyvinyl chloride)			
PVDF (polyvinylidene fluoride)			
Sensor interface			
Pg 13.5 (with protective cage P or GP available)			
3/4" NPT			
Cond 1" NPT			
IND (for InPro 7250)			
Protective Cage			
P			
GP			

InDip 550	Insertion Length	Material	Sensor Interface	Protective Cage
	1000	PVC	Cond 1" NPT	-
	1500	PVDF	Pg 13.5	-
	2000	PVC	Pg 13.5	GP

*Other lengths on request

Important addition to the order information for InDip 550 housings

Flanges for the InDip 550 have to be ordered separately. They cannot be included to the part number of the housing. Local assembly of InDip housings is also possible. Ask your local METTLER TOLEDO representative.

Did You Know

Measurement loops from METTLER TOLEDO can be automated with the EasyClean systems for rinsing, cleaning, and calibrating. See pages 136-141 for more information.



InFlow Series Modular, Highly Adaptable Flow-Through Housings



InFlow 761



InFlow 762



InFlow 751

InFlow 76X flow-through housings from METTLER TOLEDO are designed to enable safe and reliable mounting of the InTrac and InFit series sensor housings directly into the process or in a bypass (pipe). These rugged flow-through housings are specially suited to the requirements of the process industry and can be easily and safely installed, allowing reliable measurement procedures.

InFlow 751 flow-through housings serve for the direct fitting of METTLER TOLEDO electrodes and sensors for the measurement of pH, ORP, dissolved oxygen, conductivity and turbidity, particularly in the field of industrial wastewater treatment. The housings protect electrodes/sensors against mechanical damage.

Specifications

	InFlow 751, PVC Version	InFlow 751, PVDF Version
Wetted parts	PVC	PVDF
Surface finish	N/A	N/A
(O-ring groove/Other)		
O-ring	Viton®-FDA	Viton®-FDA
Sensor/housing fitting	Pg 13.5, 1" NPT, ¾" NPT	Pg 13.5, 1" NPT, ¾" NPT
Temperature range	0–60 °C/32–140 °F	0–100 °C/32–212 °F
Pressure rating	1 bar/60 °C (14.5 psi/140 °F)	1 bar/100 °C (14.5 psi/212 °F)
(Sensor dependent)	4 bar/45 °C (58 psi/113 °F)	4 bar/75 °C (58 psi/167 °F)

	InFlow 761	InFlow 762
Wetted parts	Stainless 316L	PVDF
Surface finish	N/A	N/A
(O-ring groove/Other)		
O-ring	N/A	Viton®-FDA*
Sensor/housing fitting	InTrac 7XX, InFit 76X	InTrac 7XX, InFit 76X
Temperature range	0–140 °C/32–284 °F	0–140 °C/32–284 °F
Pressure rating	16 bar/140 °C (232 psi/284 °F)	1 bar/140 °C (14.5 psi/284 °F)
(Sensor dependent)		6 bar/80 °C (87 psi/176 °F)

Certificates and Approvals CE, Pressure Equipment Directive guidelines (PED)

* Version with Ingold DN25 socket

Features Overview

- Correctly positions sensors in tight confines of narrow pipes and slip streams
- Wide variety of materials and process connections to accommodate common process environments
- Optimally designed for use with METTLER TOLEDO housings and sensors

Suggested Sensors

	pH	DO	CO ₂	Conductivity	Turbidity
465	InPro 6050		InPro 5000 (i)	InPro 7001	InPro 8050
InPro 2000 (i)	InPro 6800 (G)			InPro 7100 (i)	InPro 8100
InPro 3250 (i)	InPro 6850 (i) (G)				
InPro 4010	InPro 6900 (i) (G)				
InPro 4260 (i)	InPro 6950 (i) (G)				
InPro 4501					
InPro 4800					
DPA					
DXK					

Sensor Fit Guide

Sensor Length	InFlow 751	InFlow 76X
120mm	•	•

1 See appropriate housing section

Many housing options are available. Please use the product configurator found on p. 123.

► www.mt.com/InFlow

Ordering Information for InFlow 751

InFlow 751

– PVC Version	Process Connect	Bore Size	Insert Length	Wetted Parts	Order Number
InFlow 751 d32DN25	Pg 13.5	32 mm	N/A	PVC	52 400 250
InFlow 751 d32DN25	NPT ¾"	32 mm	N/A	PVC	52 400 256
InFlow 751 d50DN40	Pg 13.5	50 mm	N/A	PVC	52 400 251
InFlow 751 d50DN40	NPT ¾"	50 mm	N/A	PVC	52 400 257
InFlow 751 d50DN40	NPT 1"	50 mm	N/A	PVC	52 400 644
InFlow 751 d63DN50	Pg 13.5	63 mm	N/A	PVC	52 400 252
InFlow 751 d63DN50	NPT ¾"	63 mm	N/A	PVC	52 400 258
InFlow 751 d63DN50	NPT 1"	63 mm	N/A	PVC	52 400 645
– PVDF Version					
InFlow 751 d32DN25	Pg 13.5	32 mm	N/A	PVDF	52 400 253
InFlow 751 d32DN25	NPT ¾"	32 mm	N/A	PVDF	52 400 259
InFlow 751 d50DN40	Pg 13.5	50 mm	N/A	PVDF	52 400 254
InFlow 751 d50DN40	NPT ¾"	50 mm	N/A	PVDF	52 400 260
InFlow 751 d50DN40	NPT 1"	50 mm	N/A	PVDF	52 400 646
InFlow 751 d63DN50	Pg 13.5	63 mm	N/A	PVDF	52 400 255
InFlow 751 d63DN50	NPT ¾"	63 mm	N/A	PVDF	52 400 261
InFlow 751 d63DN50	NPT 1"	63 mm	N/A	PVDF	52 400 647

For the housing configuration of the InFlow 76X, please use the product configurator below.

Product configurator for InFlow 76X – not all configurations are possible

Material (others on request)																			
1	/	4	4	0	4	1.4404/316L PVDF (polyvinylidene fluoride)													
2	/	P	V	D	F	Flow-through direction													
						1	8	0	180°										
						-	9	0	90°										
Process connection*																			
D	2	5	DIN flange DN25 PN16																
D	5	0	DIN flange DN50 PN16																
A	0	1	ANSI flange A150-1"																
A	0	2	ANSI flange A150-2"																
W	2	5	Welding connection DN25 (1")																
W	5	0	Welding connection DN50 (2")																
Housing connection*																			
D	0	0	Ingold DN25																
D	0	4	DIN flange DN50																
			Special																
			Standard																
			Special																
InFlow 76																			
	/		/		/		/		/										
9	10	11	12	13	14	15	16	17	18	19	20	21	22	23	24	25	26	27	28



Seals

The InFlow 76X PVDF version with Ingold DN25 socket

is fitted with a medium-wetted O-ring made of Viton®. O-ring sets made of EPDM and Kalrez® are available as accessories.



Important addition to the order information for InDip 550 housings

Flanges for the InDip 550 have to be ordered separately. They cannot be included to the part number of the housing. Local assembly of InDip housings is also possible. Ask your local METTLER TOLEDO representative.



Did You Know

Measurement loops from METTLER TOLEDO can be automated with the EasyClean systems for rinsing, cleaning and calibrating. See pages 136–141 for more information.

InFlow 724-120

Modular, Highly Adaptable Flow-Through Housings



The InFlow 724-120 housing from METTLER TOLEDO is designed for easy and reliable side-stream analytical measurements. The InFlow 724-120 accepts all Pg 13.5, 120 mm pH/redox, DO, CO₂, and conductivity electrodes. The housing is constructed of all wetted 316L Stainless Steel and is provided with an integral wall mount bracket for ease of installation. Inlet and outlet connections are 1/4" NPT with the internal design engineered for limited hold-up volume and flow consumption. The 724-120 provides ideal side-stream measurement and can be installed with an upstream throttle/shut-off valve to limit flow consumption and allow operational service without process shut-down.

Specifications

Wetted parts	Stainless 316L
O-ring	Sensor O-ring
Sensor fitting	Pg 13.5
Temperature range	0 – 140°C/32 – 284°F
Pressure rating	Max 16bar/232 psig

Features Overview

- Simple, side-stream measurement
- Easy-to-use and low maintenance
- Stainless 316L material of construction
- Universal Pg 13.5, 120 mm electrodes design
- Low hold-up volume and flow construction

Suggested Sensors

pH	DO	CO ₂	Conductivity
InPro 3100(i)	INGOLD 12 mm	InPro 5000(i)	InPro 7001
InPro 3250(i)	InPro 6800 (12 mm)		
InPro 4260(i)	InPro 6900		
InPro 4800(i)	InPro 6850i (12 mm)		
	InPro 6860i		
	InPro 6900i		
	InPro 6960i		
	InPro 6970i		

Ordering Information

Description	Order Number
InFlow 724-120/pH/DO/Cond/1/4"NPT/SS	53 400 280
InFlow 724-120/pH/DO/Cond/1/4"NPT/SS/Left Mount Outlet	53 610 009

InFlow 724-120 Dimensions

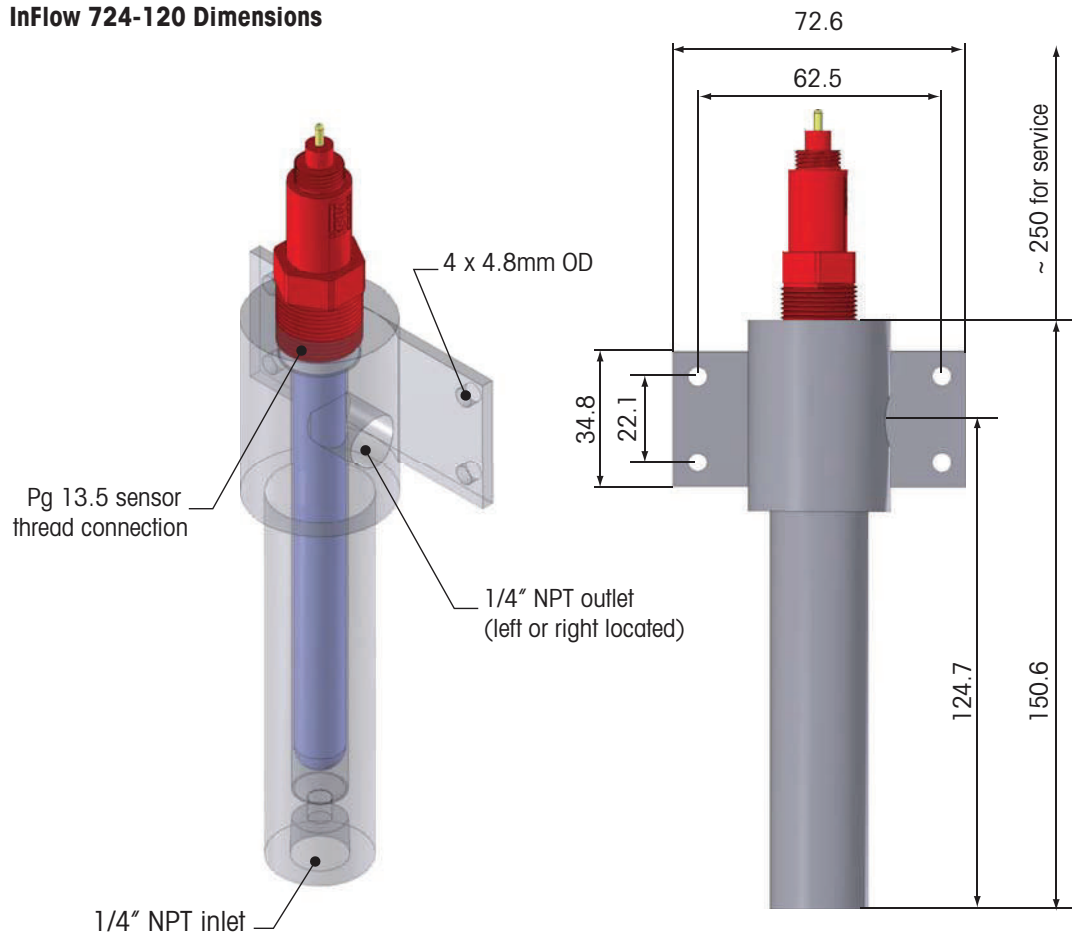

InTrac 776e For Liquid-Filled pH Electrodes



**USP
Class VI**



The retractable InTrac 776e housings are designed for applications in processes which utilize pH/ORP sensors that have a liquid electrolyte reference system such as the InPro 2000 and Ingold 465 series electrodes. The housing has a built-in flushing chamber in which the electrode can be cleaned and calibrated if necessary, both accomplished without interruption of the process. This enhanced housing incorporates the Tri-Lock™ safety system which increases process safety and reliability even in harsh applications.

Specifications

Operation	Manual or pneumatic	
Ambient temperature	Polypropylene:	0 to 70 °C (32 to 158 °F)
	Stainless steel:	- 10 to 70 °C (14 to 158 °F)
Functional pressure range	Manual:	0 to 5 bar (0 to 73 psig)
	Pneumatic:	0 to 6 bar (0 to 87 psig)
Max. permissible pressure	Polypropylene (PP):	6 bar at 20 °C (87 psig at 68 °F)
	PVDF, PEEK:	6 bar at 20 °C (87 psig at 68 °F)
	316 L stainless steel:	6 bar at 140 °C (87 psig at 276 °F)
	Hastelloy /Ti:	6 bar at 140 °C (87 psig at 276 °F)
Insertion lengths	70 mm, 100 mm, 200 mm (2.76", 3.94", 7.87")	
Wetted parts	316 L stainless steel, Hastelloy – C22, titanium, PP, PVDF, PEEK	
Wetted O-rings	Viton®-FDA, EPDM-FDA, Kalrez®-FDA-USP Class VI	
Housing length	70/100 mm:	545 mm (21.8") in process
		710 mm (28") retracted from process
	200 mm:	645 mm (25.4") in process 1110 mm (43.7") retracted from process
Pneumatic conditions	4 to 8 bar (58 to 116 psig)	
Flushing connections (water, steam)	2 to 6 bar (29 to 87 psig)	
Position monitoring (options)	Pneumatic check (3/2 way valve), G1/8"	
	Inductive check, non-Ex, M12 × 1	
	Inductive check, Ex, M12 × 1	

Certificates and Approvals

CE;
Pressure Equipment Directive guidelines (PED);
Certificate of conformity according to EN10204-2.1;
Material certificate according to 3.1;
ATEX, FM and MaxCert

Sensor Fit Guide (for Liquid-Filled Glass pH Electrodes)

Sensor Length	Insertion Length		
	70 mm	100 mm	200 mm
250 mm	•	•	–
450 mm	–	–	•

Many housing options are available. Please use the product configurator found on p. 131.



Did You Know

Measurement loops from METTLER TOLEDO can be automated with the EasyClean systems for rinsing, cleaning and calibrating. See pages 136–141 for more information.

► www.mt.com/InTrac776

InTrac 777 e/779 e

The Reliable All-Rounder



Features Overview

- Advanced Tri-Lock safety system
- Remove sensor without interrupting of the process
- Automation with EasyClean

Other Highlights

- Multiple process connections available
- For use with 12 mm Ingold sensors
- MaxCert covers necessary certifications
- Increased operational safety and reliability
- Several materials of construction available

▶ www.mt.com/InTrac777
▶ www.mt.com/InTrac779

The retractable InTrac 777 e/779 e housings are specifically designed for applications in processes which utilize 12 mm pH, ORP, dissolved oxygen, CO₂, conductivity, and turbidity (InTrac 779e) sensors. The housing has a flushing chamber in which the electrode can be cleaned and calibrated if necessary, both accomplished without interruption of the process. This enhanced housing incorporates the Tri-Lock safety system which increases process safety and reliability even in harsh applications. Multiple process connections and materials of construction make the InTrac 777 e/779 e an excellent choice for use in either the chemical, biopharmaceutical or food and beverage industries.

Specifications

Operation	Manual or pneumatic (295 mm version pneumatic only)
Ambient temperature	Polypropylene: 0 to 70 °C (32 to 158 °F) Stainless steel: – 10 to 70 °C (14 to 158 °F)
Functional pressure range	Manual: 0 to 5 bar (0 to 73 psig) Pneumatic: 0 to 16 bar (0 to 232 psig)
Max. permissible pressure	Polypropylene (PP): 6 bar / 20 °C (87 psig / 68 °F) PVDF, PEEK: 6 bar / 20 °C (87 psig / 68 °F) 316 L stainless steel: 16 bar / 140 °C (232 psig / 276 °F) Hastelloy / Ti: 16 bar / 140 °C (232 psig / 276 °F)
Insertion lengths	70 mm, 100 mm, 200 mm, 295 mm (2.76", 3.94", 7.87", 11.61")
Wetted parts	316 L stainless steel, Hastelloy-C22*, titanium, PP*, PVDF*, PEEK*, * not available for 295 mm version
Wetted O-rings	Viton®-FDA, EPDM-FDA, Kalrez®-FDA and USP Class VI
Housing length	70 / 100 mm: 360 mm (14.2") in process 515 mm (20.3") retracted from process 200 mm: 460 mm (18.1") in process 915 mm (36") retracted from process
Pneumatic conditions	4 to 8 bar (58 to 116 psig)
Flushing connections (water, steam)	2 to 6 bar (29 to 87 psig)
Position monitoring (options)	Pneumatic check (3/2 way valve), G 1/8" Inductive check, non-Ex, M12 × 1 Inductive check, Ex, M12 × 1
Certificates and Approvals	CE; Pressure Equipment Directive guidelines (PED); Certificate of conformity according to EN10204-2.1; Material certificate according to 3.1; ATEX, FM and MaxCert

Many housing options are available. Please use the product configurator and sensor fit guide found on p. 131.



Did You Know

Measurement loops from METTLER TOLEDO can be automated with the EasyClean systems for rinsing, cleaning and calibrating. See pages 136–141 for more information.

InTrac 797 e/799 e When Sterile Conditions Are Required



USP
Class VI



Features Overview

- Twin-chamber lock effectively prevents any external contamination
- Advanced Tri-Lock safety system
- Remove sensor without interrupting of the process

Other Highlights

- Multiple process connections available
- For use with 12 mm Ingold sensors
- Double flushing chamber
- Increased operational safety and reliability

The retractable InTrac 797 e/799 e housings are specifically designed for applications in processes which utilize 12 mm pH, ORP, dissolved oxygen, CO₂, conductivity, and turbidity (InTrac 799 e) sensors. This sterilizable housing has a double flushing chamber which was designed to meet the highest demands of the pharmaceutical and food and beverage industries where sterile conditions are required. The double flushing chamber allows complete sterilization of the upper and lower sections of a sensor and insertion shaft allowing the electrode/ sensor to be removed and replaced under a completely sterile environment.

Specifications

Operation	Manual or pneumatic	
Ambient temperature	Stainless steel: – 10 to 70 °C (14 to 158 °F)	
Functional pressure range	Manual:	0 to 5 bar (0 to 73 psig)
	Pneumatic:	0 to 16 bar (0 to 232 psig)
Max. permissible pressure	316 L stainless steel: 16 bar/130 °C (232 psig at 266 °F)	
Insertion lengths	100 mm (3.94")	
Wetted parts	316 L stainless steel	
Wetted O-rings	Viton®-FDA, EPDM-FDA, Kalrez®-FDA-USP Class VI	
Housing length	100 mm:	460 mm (18.1") in process 715 mm (28.2") retracted from process
Pneumatic conditions	4 to 8 bar (58 to 116 psig)	
Flushing connections (water, steam)	2 to 6 bar (29 to 87 psig)	
Position monitoring (options)	Pneumatic check (3/2 way valve), G1/8"	
	Inductive check, non-Ex, M12 × 1	
	Inductive check, Ex, M12 × 1	

Certificates and Approvals

CE;
Pressure Equipment Directive guidelines (PED);
Certificate of conformity according to EN10204-2.1;
Material certificate according to 3.1;
ATEX, FM and MaxCert

InTrac 797 e/InTrac 799 e Sensor Fit Guide

Sensor Length	Insertion Length	
297 mm	100 mm	∅ 12 mm Sensor / electrode
320 mm	•1	Turbidity
325 mm	•2	O ₂ , CO ₂
	•2	pH/ORP

1 InTrac 799 e only

2 InTrac 797 e only

Many housing options are available. Please use the product configurator found on p. 132.

▶ www.mt.com/InTrac797
▶ www.mt.com/InTrac799

InTrac 781/784

Designed for the Toughest Process Conditions



InTrac 781

InTrac 784

Other Highlights

- Multiple process connections available
- Large choice of materials for wetted parts
- Variable insertion length
- Compliance with international standards
- Long life and easily exchangeable seals

The InTrac 781/784 retractable housings combine rugged design with great versatility to meet the demands of the harshest process conditions in chemical, petrochemical, pulp and paper, or utilities applications.

The InTrac 781 operates mainly with the 12 mm diameter (Pg 13.5) sensors, while the InTrac 784 operates with the InPro 2000 (i)/465 pH/ORP sensor.

The retractable housing material is specially designed for a range of harsh applications. Wetted parts are available in different materials (1.4404/SS 316L; Alloy C-22, PP; PVDF or PEEK), offering installation flexibility in many applications. The intelligent sensor locking system in the housing enhances operational safety. Without the presence of a sensor, the housing cannot be inserted into the process. Also, it makes it possible to remove the sensor from the housing when in the service position.

Specifications

Operation	Manual or pneumatic or pneumatic with inductive check back
Ambient temperature	SS 316L, Alloy C-22: -10 to 70 °C (14 ... 158 °F) PP, PVDF, PEEK: 0 to 70 °C (32 ... 158 °F)
Max. permissible pressure and temperature	SS 316L, Alloy C-22: 16 bar/120 °C or 10 bar/140 °C (232 psi/248 °F or 145 psi/284 °F) PP: 4 bar/60 °C or 2 bar/70 °C (58 psi/140 °F or 29 psi/158 °F) PVDF: 6 bar/90 °C or 4 bar/100 °C (87 psi/194 °F or 58 psi/212 °F) PEEK: 10 bar/100 °C or 6 bar/120 °C (145 psi/212 °F or 87 psi/248 °F)
Insertion length	80 mm (3.15") or 280 mm (11.02")
Wetted parts	SS 316L, Alloy C-22, PP, PVDF, PEEK or PVDF
Wetted O-rings	Viton®, Kalrez® or EPDM
Process connections	Flanges: DIN or AISI, or NPT 1 1/4"
Pneumatic condition	4 to 6 bar
Flushing condition (water)	1 to 6 bar
Certificates and Approvals	CE; Pressure Equipment Directive guideline (PED); ATEX and FM

Many housing options are available. Please use the product configurator found on p. 133.

Features Overview

- Highly efficient cleaning chamber
- Intelligent sensor locking system to prevent unintentional removal of the sensor
- Integrated sensor protective cage to protect the sensor in cases of fast process flow
- Specially designed drive train allows sensor retraction from high process pressures and temperatures
- Automated sensor cleaning with EasyClean

Retractable Housings

Sensor Access Without Process Interruption



Housings

InTrac 785/787 For Harsh Applications



InTrac 785

InTrac 787

InTrac 785/787 is a rugged, retractable housing for the most demanding industrial applications. Sensor maintenance and replacement becomes a fast and easy task using the InTrac 785/787, and can be done without any interruption to your process. Once retracted, the integral ball valve completely seals off your process, preventing loss of medium or contamination. The design allows for direct mounting to process lines, tanks and reactor vessels.

The InTrac 785 allows a wide range of installation possibilities, thanks to the wide variety of process connections and materials for wetted parts. If the ball valve is already present or a factory standard needs to be used, this housing is also available without ball valve and process connection.

Specifications	InTrac 785	InTrac 787
Wetted parts	316L, C22, titanium Ball valve always made of 1.4408	Stainless 316L
Surface finish	N6 (Ra 32)	N6/N5 (Ra 32/Ra 16)
O-ring	Viton®, Kalrez®	Viton®-FDA
Sensor fitting	Pg 13.5	Pg 13.5
Temperature range	Up to 140 °C/276 °F	Up to 140 °C/276 °F
Pressure rating	16 bar (232 psi)	9 bar (130 psi)

Certificates and Approvals CE, Pressure Equipment Directive guidelines (PED)

Suggested Sensors InTrac 785

pH	DO	CO ₂	Conductivity	Turbidity
All 425 mm	All 420 mm	N/A	InPro 7100/425*	All 409 mm

* with InTrac 785 without protective cage

Suggested Sensors InTrac 787 (all 120 mm length)

pH	DO	CO ₂	Conductivity	Turbidity
InPro 3030	InPro 6050	N/A	InPro 7001	InPro 8050
InPro 3100 (i)	InPro 6800 (G)		InPro 7108	InPro 8100
InPro 3250 (i)	InPro 6850 (i) (G)		InPro 7100 (i)	InPro 8200
InPro 4010	InPro 6900 (i) (G)			
InPro 4260 (i)	InPro 6950 (i) (G)			
InPro 4281 i				
InPro 4800 (i)				
InPro 4881 (i)				
DPA				
DPAS				
DXK				

Many housing options are available. Please use the product configurator for InTrac 785 found on p. 132 or ordering information for InTrac 787 found on p. 133.

Features Overview

- Anti-blowout tip prevents accidental blowout
- Variable insertion length
- Flushing chamber available
- Wide range of installation options
- Flexibility in maintenance intervals due to sensor access during running process
- Smooth and reliable operation even in applications with high fiber concentration

▶ www.mt.com/InTrac785
▶ www.mt.com/InTrac787

Accessories for InTrac 775, 776, 777, 779, and 797 Housings

	Order Number
Swagelok Kit for 777/776, 1/4" tube, SS	53 600 032
Swagelok Kit for 79X, 1/4" tube, SS	53 600 003
InTrac pneu. position indicators, 3/2 way reversion valve set	52 403 023
Position indicator non-Ex (2 pcs)	52 403 024
Position indicator Ex (2 pcs)	52 403 025

Product Configurators

InTrac 777 e/InTrac 779 e Sensor Fit Guide

Sensor Length	Insertion Length			
	70 mm	100 mm	200 mm	295 mm
205 mm (Turbidity)	• ¹	• ¹	–	–
220 mm (O ₂ /CO ₂)	•	•	–	–
225 mm (pH/ORP)	•	•	–	–
407 mm (Turbidity)	–	–	• ¹	–
420 mm (O ₂ /CO ₂)	–	–	•	•
425 mm (pH/ORP/Conductivity)	–	–	•	•

¹ InTrac 779e only

Product configurator: InTrac 775 e, InTrac 776 e, InTrac 777 e, and InTrac 779 e – not all configurations are possible

Flushing chamber									
7	Single flushing chamber								
Electrode/sensor type									
5	pH electrodes with dual-membrane, pNa reference system (only available in PVDF or Titan with 70 or 100mm Insertion length)								
6	pH electrodes with liquid electrolyte (not available with the 295 mm version)								
7	pH electrodes with gel/polymer electrolyte and sensors with Pg 13.5 thread								
9	Turbidity sensors (not available with the 295 mm version)								
Operation mode									
M	Manual operation (not available with the 295 mm version)								
P	Pneumatic operation								
R	Pneumatic operation with pneumatic position indication								
I	Pneumatic operation with inductive position indication, non-Ex								
X	Pneumatic operation with inductive position indication, Ex								
Insertion length (H)									
0	7	0	H=70 mm						
1	0	0	H=100 mm						
2	0	0	H=200 mm						
2	9	5	H=295 mm						
Material (wetted parts)									
4	4	0	4	DIN 1.4404/AISI 316 L (stainless steel)					
C	2	2	–	DIN 2.4602/Alloy C22 (on request for 295 mm version)					
T	i	–	–	Titanium (on request for 295 mm version)					
P	P	–	–	Polypropylene (not available with the 295 mm version)					
P	V	D	F	Polyvinylidene fluoride (not available with the 295 mm version)					
P	E	E	K	Polyetherether ketone (not available with the 295 mm version)					
Process connection									
D	0	0	0	Ingold DN25 weld-in socket					
D	0	2	–	Flange DN32 PN16 (SS version only)					
D	0	3	–	Flange DN40 PN16					
D	0	4	–	Flange DN50-PN16					
A	0	2	–	ANSI Flange A150-1 1/2"					
A	0	3	–	ANSI Flange A150-2"					
A	0	4	–	ANSI Flange A150-3"					
N	0	1	–	NPT 1"					
N	0	2	–	NPT 1 1/4"					
N	0	3	–	NPT 1 1/2"					
T	0	1	–	Tri-Clamp flange 1 1/2", straight					
T	0	2	–	Tri-Clamp flange 2", straight					
V	0	1	–	Varivent flange DN50, straight					
O-ring material									
V	i	–	–	FKM Viton® FDA					
E	P	–	–	EPDM FDA					
K	a	–	–	FFKM Kalrez® 6230 FDA/USP Class VI					
Body material									
A	S	–	–	PP conducting (not for 295 mm)					
				DIN 1.4404/316L					
Flushing connections									
0	Without								
1	Serto ss								
2	PVC								
3	PVDF								
4	Gyrolok™ ss								
5	Swagelok ss								
Special									
0	Standard								
1	Special								

InTrac 77X e
Hastelloy and titanium housings have cap nuts made of stainless steel. Varivent and Tri-Clamp flanges are available in stainless steel only.

InTrac 7 / / / / / /

Viton and Kalrez are registered trademarks of DuPont Performance Elastomers LLC

Retractable Housings

Sensor Access Without Process Interruption

Housings

Product configurator: InTrac 797 e, InTrac 799 e – not all configurations are possible

Flushing chamber																																			
9	Double flushing chamber																																		
Electrode/sensor type																																			
7	pH electrodes with gel/polymer electrolyte and sensors with Pg 13.5 thread																																		
9	Turbidity sensors																																		
Operation mode																																			
M	Manual operation																																		
P	Pneumatic operation																																		
R	Pneumatic operation with pneumatic position indication																																		
I	Pneumatic operation with inductive position indication, non-Ex																																		
X	Pneumatic operation with inductive position indication, Ex																																		
Insertion length (H)																																			
1	0	0	H=100mm																																
Material (wetted parts)																																			
4	4	0	4	DIN 1.4404/AISI 316L (stainless steel)																															
Process connection																																			
D	0	0	Ingold DN25 weld-in socket																																
T	0	1	Tri-Clamp flange 1½", straight																																
T	0	2	Tri-Clamp flange 2", straight																																
V	0	1	Varivent flange DN50, straight																																
O-ring material																																			
V	i	FKM Viton®-FDA																																	
E	P	EPDM-FDA																																	
K	a	FFKM Kalrez® 6230-FDA/USP Class VI																																	
Body material																																			
A	PP conducting																																		
S	DIN 1.4404/316L																																		
Flushing connections																																			
0	Without																																		
1	Serto ss																																		
4	Gyrolok ss																																		
5	Swagelok ss																																		
Special																																			
0	Standard																																		
1	Special																																		
InTrac 7				/				/					/					/							/										
	8	9	10		11	12	13	14	15	16	17	18	19	20	21	22	23	24	25	26	27	28	29	30											

Product configurator: InTrac 785 – not all configurations are possible

Electrode/Sensor type																																			
5	For pH, turbidity and oxygen sensors (length 425 mm/409 mm/420 mm)																																		
Sensor holder																																			
A	Standard with protective cage (sensor design Ø 12 mm shaft and Pg 13.5 thread)																																		
B	Without protective cage																																		
Flushing chamber																																			
F	Including flushing chamber																																		
N	No flushing chamber																																		
Insertion length																																			
2	2	0	220 mm/8.66" immersion length (insertion length can be adjusted from 0–220 mm/0"–8.66")***																																
Material (wetted parts)																																			
4	4	3	5	DIN 1.4435/316L																															
C	2	2	-	DIN 2.4602/Alloy C22*																															
T	i	-	-	Titanium*																															
Process connections																																			
N	1	0	NPT 1"																																
N	1	4	NPT 1¼" (with adapter 1" to 1¼")																																
A	0	2	ANSI A150–1.5" (with adapter 1" NPT to ANSI A150–1.5")																																
D	0	4	DIN DN50–PN16 (with adapter 1" NPT to DIN DN50–PN16)																																
w	/	o	Without ball valve and process connection for direct installation**																																
O-Ring material																																			
V	i	FKM Viton®																																	
K	a	FFKM Kalrez®																																	
Special																																			
-	Standard																																		
S	Special																																		
InTrac 7 8				/				/					/					/							/										
	10	11	12	13	14	15	16	17	18	19	20	21	22	23	24	25	26	27	28	29	30	31													

* Ball valve made of SS 1.4408, ** For exact ball valve requirements please refer to the instruction manual,

*** Insertion length will be reduced by 40 mm/1.56" by using a flushing chamber.

InTrac 788

Cost-effective retractable housing



The InTrac 788 retractable housing is a cost-effective solution for demanding chemical applications which require extended reach of combination pH/ORP sensors. Chemically resistant titanium inserts house Intelligent Sensor Management® (ISM) pH/ORP sensors in one inch diameter 316 SS or titanium tube fluorocarbon (FKM) or perfluoroelastomer (FFKM) wetted materials of construction. An optional swagged compression nut with 1 inch NPT process connection is available in 316SS/FFKM construction to set the insertion length from 1 to 36 inches.

Features Overview

- Select from four types of Intelligent Sensor Management® (ISM) pH/ORP sensors
- Chemically resistant materials of construction
- Sensor maintenance without process interruption when used with isolation valve
- Extended insertion reach up to 36 inches suited for reactor, tank or pipe installations
- Low cost of ownership with durable 0.065" wall tube

Specifications

Applications	Insertion, Hot-tap, or Static
Max. pressure/temperature*	100 psi at 68°F / 5 bar at 20°C 50 psi at 200°F / 3 bar at 94°C
Operation	Manual
Insertion tube length	36 inches
Wetted parts	titanium Grade 2 with 316SS or titanium 1" tube
Wetted O-rings	Fluorocarbon (FKM) or perfluoroelastomer (FFKM)
Non-wetted parts	CPVC (insert lock)
Process connection/ Compression fitting	- 316SS, 1" Male NPT x 1" tube FKM O-ring, or PTFE front ferrule and nylon back ferrule - titanium, 1" Male NPT x 1" tube FFKM O-ring, or PTFE front ferrule and nylon back ferrule

* Sensor dependent

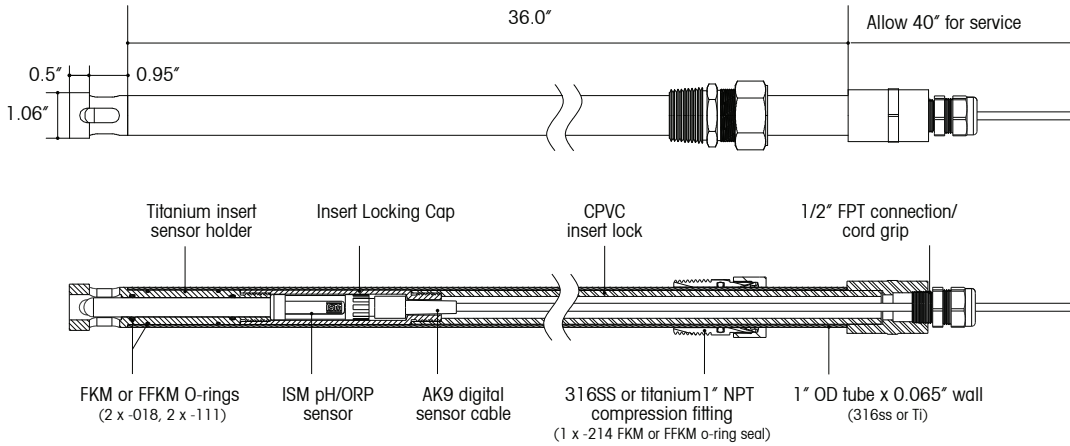

Ordering Information

Base Housing	Order Number
InTrac 788/SS/FFKM (compression fitting provided separately)	53 300 101
InTrac 788/Ti/FFKM (compression fitting provided separately)	53 300 102
InTrac 788 SS/FFKM compression fitting	53 300 105
InTrac 788 Ti/FFKM compression fitting (supplied with non-wetted 316 SS cap nut)	53 300 114

Spares, replacements, and accessories	Order Number
InTrac 788 titanium insert (without O-rings)	53 300 103
InTrac 788 CPVC insert lock	53 300 104
Kit, O-Ring, InTrac 788, FKM (5 pieces: 2 x 2-018, 2 x 2-111, 2 x 2-214)	53 300 107
Kit, O-Ring, InTrac 788 FFKM (5 pieces: 2 x 2-018, 2 x 2-111, 2 x 2-214)	53 300 108
O-Ring replacement tool set	59 908 798

ISM pH/ORP sensors (InTrac 788 not for use with sensors not listed below)	Order Number
InPro 3250i/SG/120-NT	30 041 285
InPro 4260i/SG/120-NT	30 041 286
InPro 4800i/SG/120-NT	30 041 287
InPro 4850i/SG/125-NT	30 041 288

ISM pH/ORP sensors cables	Order Number
Cable, AK9/3m coax/tinned	59 902 193
Cable, AK9/5m coax/tinned	59 902 213
Cable, AK9/10m coax/tinned	59 902 230
Cable, AK9/20m coax/tinned	52 300 204
Cable, AK9/50m coax/tinned	52 300 394
Cable, AK9/80m coax/tinned	52 300 395
ISM extension cable/3m	52 004 012



Did You Know
 The InTrac 788's unique insert design accepts both the listed 120mm pH ISM sensors and the 4850i 125mm sensor.

Did You Know
 InTrac 788 can be used with any full-port 1-1/4" or larger ball valve for process isolation during sensor maintenance. The housing's 1" NPT process connection is simply connected to an end-user supplied ball valve and appropriate transition fitting to cleanly pass the sensor end through an open valve.

EasyClean

Process Reliability Through Targeted Automation

EasyClean systems are feature-rich and compact. Chemical processing, food processing, bio-pharmaceutical processes, and other industrial applications all benefit from EasyClean's ability to automate routine maintenance. Just choose the most appropriate Ingold sensor, housing, and transmitter for your process, then add an EasyClean system to give you the exact amount of automation you need.

Flexibility of sensor maintenance
 In conjunction with the METTLER TOLEDO Ingold transmitter line, sensor maintenance is fully automated. However, manual operation is also possible whenever required. An integrated controller identifies each ongoing working step, as well as any functional problems within the system.

Safety
 EasyClean carries out continuous system diagnostics. In the event of any system anomaly the electrode remains inserted in the sample medium in order to ensure continued parameter measurement and prevent process interruption.

System overview EasyClean 400

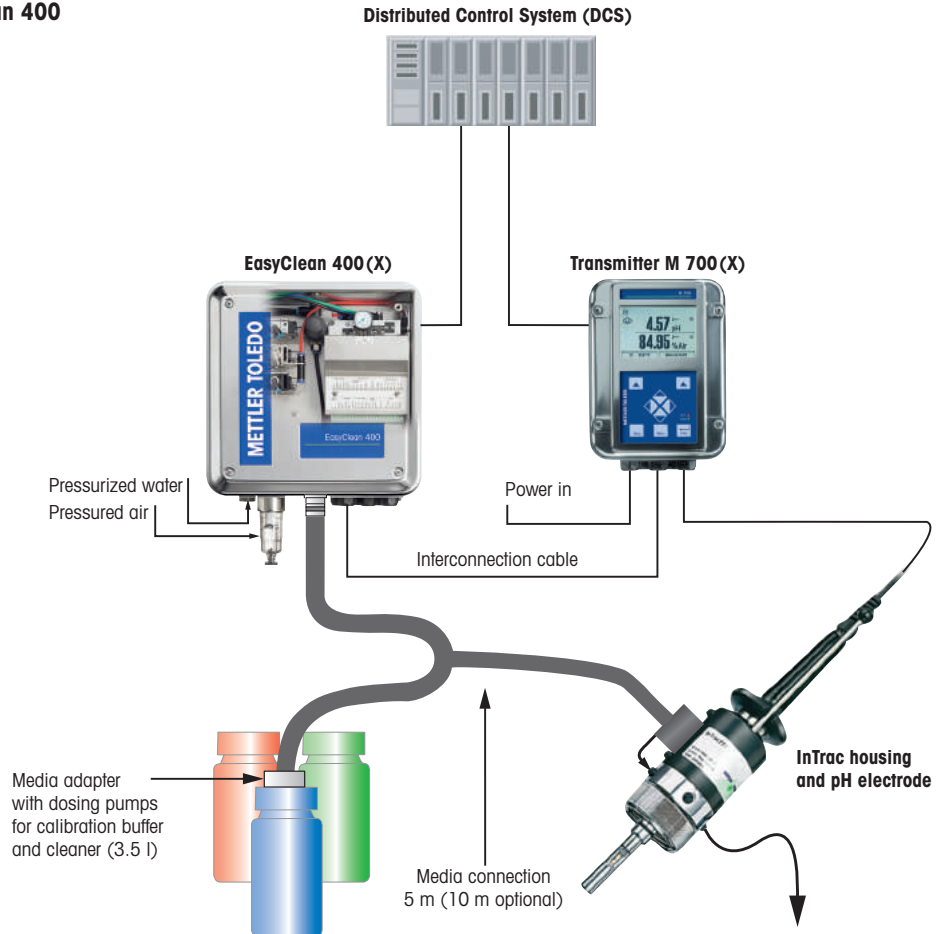

EasyClean Configuration

Custom

	EC 400(X)	EC 200e	EC 150	EC 100
Functionality				
Flushing	●	●	●	●
Cleaning	●	●	●	●
Calibration	●	●	●	●
System integration	●	●	●	●
PROFIBUS® PA/FOUNDATION™ fieldbus	●	●	●	●
Ex areas	●	●	●	●
Housing				
InDip 550				●
InTrac 7XXe	1	2	●	●
Transmitter				
M300		●	●	●
M400		●	●	●
M400 2-wire		●	●	●
M700 (X)		●	●	●
M800	●	●	●	●
Sensor				
pH	●	●	●	●
O ₂	●	●	●	●
CO ₂	●	●	●	●
Turbidity	●	●	●	●
Conductivity	●	●	●	●
1 with pneumatic position indicators				
2 with inductive position indicators				

This section will assist you with configuration based upon your specific requirements. The following example creates a fully automated EasyClean system for a “typical” industrial processing application. For harsh chemical environments, choose a compatible industrial sensor housing combination and an EasyClean system to give you the level of automation desired. The ordering information provided on p. 141 will help you choose the appropriate system components. Please make sure you choose one item from each of the sections marked with a ▲.

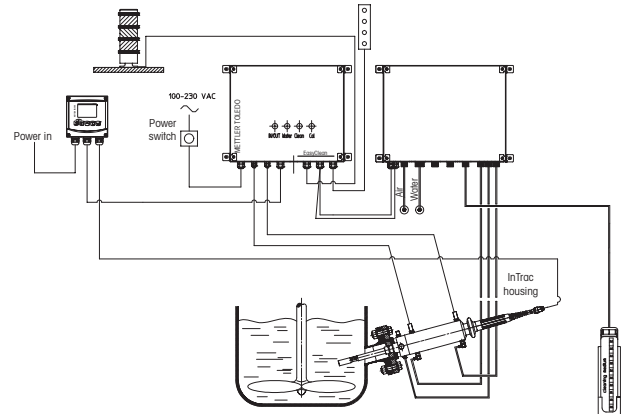

Schematic of a typical EasyClean custom installation

Configuring your EasyClean system (example)

	Product Description	Order Number	P.
* EasyClean system	EasyClean 200 e	52 403 776	131
Option:	Empty canister (5000 ml)	52 118 063	–
Option:	Connection cable: control unit > transmitter (5 m / 16.4 ft)	52 300 265	133
Option:	Wall mounting kit, complete	52 402 306	133
* Transmitter	M400 Type 1	30 374 111	86
* Sensor cable	VP cable 3 m (9.8 ft)	52 300 108	133
* Sensor	InPro 3250 SG / 225 mm	52 002 560	22
* Housing	InTrac 777 e-I	52 403 216	121

* Required system component for operation

Note: For full functionality, housings must have position sensors when used with an EasyClean 200 e or 400 system.

EasyClean 400

Flexible, for the Highest Demands



EasyClean 400 is used for fully automatic cleaning and calibration of pH measuring points. In combination with the transmitter M700 and the InTrac 7XXe retractable housing it provides a flexible system solution which can be implemented into either continuous or batch measurements. EasyClean 400 is versatile in its application. It offers multiple control possibilities and can be programmed extensively. Furthermore, a version for applications in explosion hazardous areas is available. The connection to a supervisory process control system can easily be realized in a conventional way, via PROFIBUS PA or via FOUNDATION fieldbus.

Specifications

Protection	IP 65/NEMA 4X
Power	Power supply via M700 Module EC 700 6.8V ($\pm 10\%$)/15 mA
Compressed air supply	4–10 bar (58–145 psi)
Flushing supply	2–6 bar (29–87 psi)
Pump	Delivery distance: 5 m/16.4 ft (10 m (32.8 ft) optional) Suction height: 1.5 m/4.9 ft

- **Completely unattended maintenance operation**
- **Allows maintenance teams to focus on more important and skill-intensive tasks**
- **Expanded operations without adding staff**
- **Ensured system performance and process control**

Features Overview

- Minimizes maintenance costs by fully automatic cleaning and calibration of the sensor
- Optimal adaptation to the process conditions thanks to diverse program runs with freely programmable sequences
- High flexibility thanks to free choice of individually programmable intervals or weekly programs
- EasyClean 400 ensures a safe application in explosion hazardous areas

▶ www.mt.com/EC400

EasyClean 200 e

Fully Automated Rinsing and Cleaning



The EasyClean 200e systems fully automate rinsing and cleaning procedures for the parameters pH, ORP, dissolved oxygen, CO₂, conductivity, and turbidity.

EasyClean 200e does not feature a calibration option, but it greatly reduces maintenance requirements and improves performance.

Specifications

Protection	IP 65
Power	100–230 VAC 50/60 Hz 0.18–0.3 A
Compressed air supply	4–8 bar (58–116 psi)
Flushing supply	2–8 bar (29–116 psi)
Pump	Delivery distance: 10 m (32.8 ft) Suction height: 3 m (9.8 ft)

Features Overview

- Modular configuration provides many installation options
- Many accessories available for customized installation and operational requirements

Other Highlights

- Configured for immediate operation
- Easily customized for special requirements
- Manual operation override if desired
- Fully automated operation for pH, ORP, dissolved oxygen, CO₂, conductivity, and turbidity
- Optimal cleaning effect due to the adjustable residence time

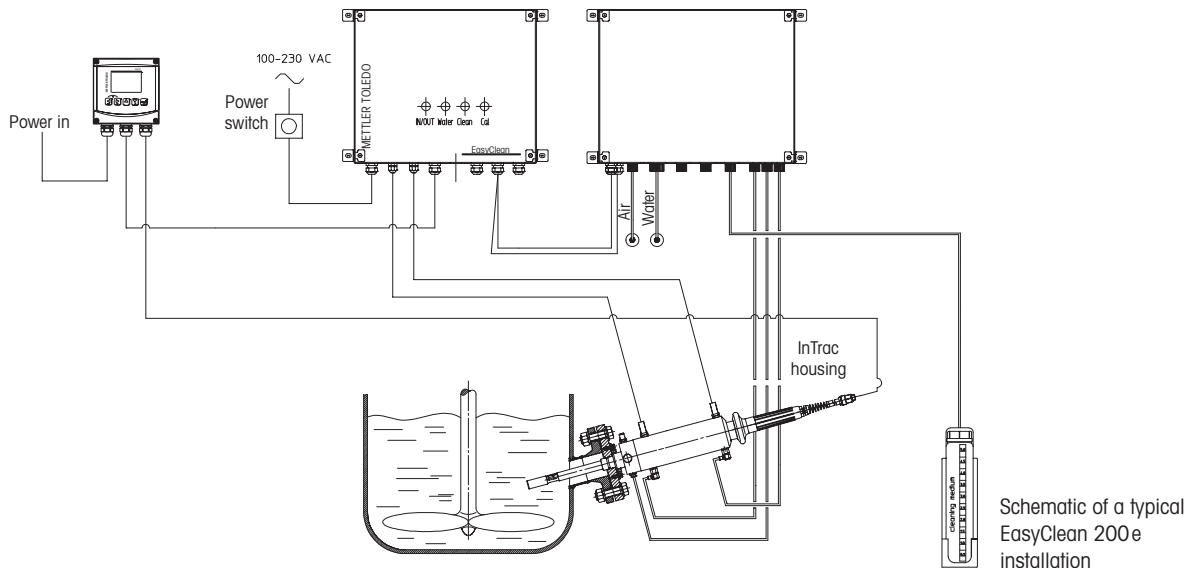

Schematic of a typical EasyClean 200e installation

EasyClean 150/100 Automated Rinsing

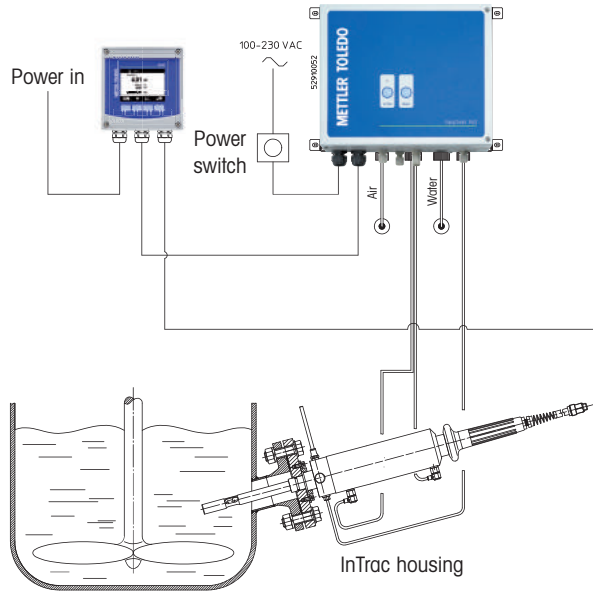

Schematic of a typical EasyClean 150 installation

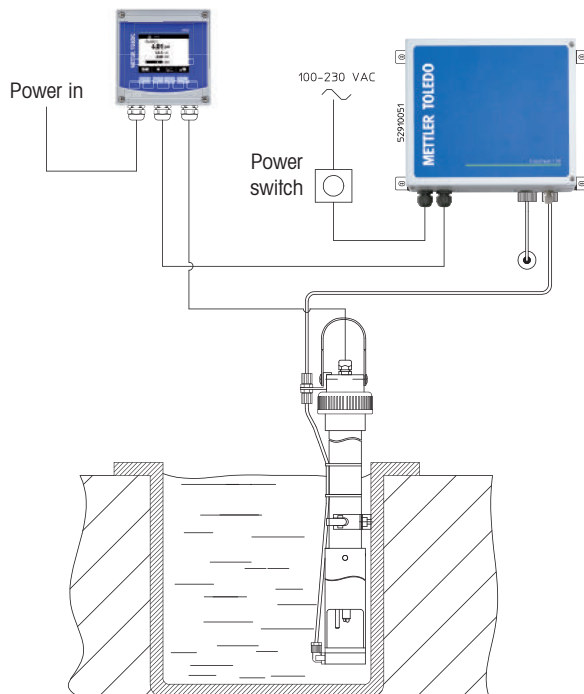

Schematic of a typical EasyClean 100 installation

The EasyClean 100 and 150 series are designed to provide completely automatic sensor rinsing. The EasyClean 100 system is designed to be used with a stationary InDip housing with a spray-head for open tank and basin applications. The EasyClean 100 can use either water rinsing or compressed air to create turbulence to prevent stubborn build-up. The EasyClean 150 works in conjunction with a retractable housing to withdraw the electrode from the process prior to automatic water rinsing.

Specifications

Protection	IP 65
Power	100–230 VAC 50/60 Hz 0.18–0.3 A
Compressed air supply	4–8 bar (58–116 psig) (EasyClean 150)
Flushing supply	2–6 bar (29–87 psig)

Features Overview

- Modular design allows complete flexibility
- Universal components for easy serviceability
- Entry-level – moderate fouling environments

Other Highlights

- Simple design and fast setup
- Standard program for immediate operation
- Manual operation override if desired



EasyClean 100 cleaning action. The bubble formation centered beneath the sensor guarantees gentle cleaning.

▶ www.mt.com/EC150
▶ www.mt.com/EC100

▲ EasyClean Systems

Product	100	150	200 e	400 (X)	Order Number
EasyClean 100	•	–	–	–	52 402 304
EasyClean 150	–	•	–	–	52 402 319
EasyClean 200 e	–	–	•	–	52 403 776
EasyClean 400 C	–	–	–	•	52 403 596
EasyClean 400 S	–	–	–	•	52 403 598
EasyClean 400 XC	–	–	–	•	52 403 597
EasyClean 400 XS	–	–	–	•	52 403 599

▲ Transmitters

M300 Process transmitter	•	•	•	–	See transmitter section
M400 transmitter	•	•	•	–	See transmitter section
M400 2-wire transmitter	•	•	•	–	See transmitter section
M700C EC700	–	–	–	•	30 628 157
M700X C/24V EC700X	–	–	–	•	30 628 259
M700X C/VPW EC700X	–	–	–	•	30 628 258
M800 transmitter	•	•	•	–	See transmitter section

▲ Sensor

pH	•	•	•	•	See all sensors
Dissolved oxygen, turbidity, conductivity, CO ₂	•	•	•	–	See all sensors

▲ Sensor Cable

VP cable–ST/3 m (9.8 ft) (pH, DO and CO ₂)	•	•	•	•	52 300 108
VP cable–ST/1.5 m (4.9 ft) (conductivity)	•	•	•	–	58 080 201
Extended length VP cable–(pH, DO and CO ₂)	•	•	•	•	See p. 136
Extended length VP cable–(conductivity)	•	•	•	–	See p. 136

▲ Sensor Housings

InTrac 7XX e	–	•	• ^②	• ^③	See housings section
InDip 550	•	–	–	–	See housings section
Spray head for InDip 550 (PVC)	•	–	–	–	52 402 291
Spray head for InDip 550 (PVDF)	•	–	–	–	52 402 290

Calibration Supplies

Buffer pH 4.01, 5000 ml	–	–	–	•	51 319 012
Buffer pH 7.00, 5000 ml	–	–	–	•	51 319 016
Buffer pH 9.21, 5000 ml	–	–	–	•	51 319 017

Options

Transmitter cable 5 m (16.4 ft)	•	•	•	–	52 300 265
Transmitter cable 10 m (32.8 ft)	•	•	•	–	52 300 266
Compressed air hose LDPE 20 m (65.6 ft)	•	•	•	–	52 402 314
Pneumatic hose PU 6/4 mm	–	•	•	–	52 401 322
Fittings pneumatic/hydraulic	–	•	•	–	52 402 337
Wall-mount kit	•	•	•	–	52 402 306
Post-mount kit	•	•	•	–	52 402 308
Weatherproof hood	•	•	•	–	52 402 316
Power switch button	•	•	•	•	52 402 317

▲ One item required for system operation

Position indicators not required

② Inductive position indicators required









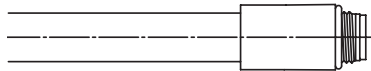
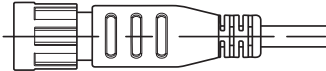

③ Pneumatic position indicators required

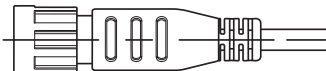
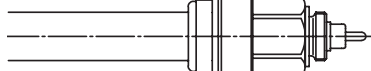
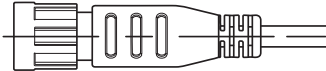
Cables and Connections Sensor Heads/Cable Sockets

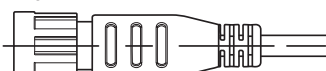
Interconnection cables from the sensor to the transmitter play an important role in providing reliable process measurements. In addition to carrying the particular parameter signal, in some cases temperature, solution ground and supply voltages are also required. Internal cable shielding and appropriate cable connectors assure noise-free, reliable signal transfer. A wide variety of cables is available to meet

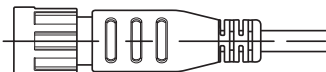
the specific installation requirement. Below is a listing of common cables. The sensor head connection is shown below in the left column with the corresponding cable connection shown directly to the right.

Available sensor / cable adapters are listed on p. 143. Contact METTLER TOLEDO for additional configurations and custom application requirements.

Sensor Heads	Adapters (see next page)	Cable Sockets	Parameter
S7 		AS9 	pH/redox
S8 (with Pg 13.5) 		AS9 	pH/redox
K8S (with Pg 13.5 autoclavable) 		AK9 	pH/redox
ISM: K8S 		AK9 	pH/redox/DO/CO ₂
K9 (autoclavable) 		AK9 	pH/redox
VP6/VP8 sensor head 		VP6/VP8 cable socket 	pH/redox/DO/ CO ₂ /Cond
O ₂ flange plug type T-82 		O ₂ cable socket T-82 	DO



Did You Know





The VP cable blind plug keeps the cable socket dry when the sensor is removed for service.

Cable Terminations

Custom Cable Plugs to Transmitter or Appliances

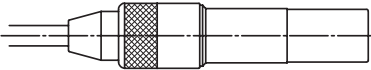
Note: Standard cables are delivered with one end open for transmitter connection. On request, cable plugs can be ordered for different appliances.

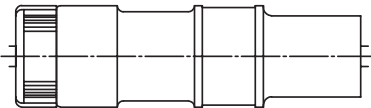
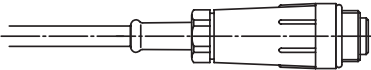
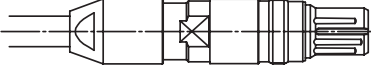
The most commonly used plugs are shown below. Ask for other types from your METTLER TOLEDO representative.

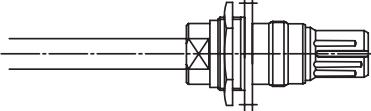
Applications		Parameter
Appliance coupler DIN 15.50D Coaxial plug (DIN 19262) for 5 mm cable		pH/redox
Appliance coupler BNC-50 Coaxial plug for 5 mm cable		pH/redox
Coax connector for gas- and watertight connection of 2 coaxial 5 mm cables		pH/redox
Cable coupler SK9 for lengthening of AS9 5 mm cable		pH/redox
VP plug		pH/redox/DO/CO ₂
VP blind plug		pH/redox/DO/CO ₂
VP apparatus plug Connection as flange or bulkhead		pH/redox/DO/CO ₂

Cable/Sensor Adapters and Cable Plugs

Description	Order Number
Adapter, to connect from K8S or K9 sensor head to AS9 cable	59 900 227
Adapter, to connect from S7 or S8 sensor head to AK9 cable	59 900 195
Adapter, to connect from T-82 sensor head to VP cable	52 200 940
Adapter, to connect from VP sensor head to T-82 cable	52 200 939
VP cable blind plug	52 300 252

Cables and Connections/Cable Terminations

Solid Connections for Safe Operation

Cables

Cable Availability Cross Reference Table

		AKO Cables with K9 or K&S Connector										Variopin (VP) Cables										-30 to 80°C / -22 to 176°F							
		Termination		Length								Termination		Length															
		Tinned Ends	Tinned Ends	0.6 m (2 ft)	1 m (3.3 ft)	3 m (9.8 ft)	5 m (16.4 ft)	10 m (32.8 ft)	20 m (65.6 ft)	30 m (98.4 ft)	50 m (164 ft)	80 m (262.5 ft)	1 m (3.3 ft)	2 m (6.6 ft)	3 m (9.8 ft)	5 m (16.4 ft)	10 m (32.8 ft)	1 m (3.3 ft)	3 m (9.8 ft)	5 m (16.4 ft)	10 m (32.8 ft)	1 m (3.3 ft)	3 m (9.8 ft)	5 m (16.4 ft)	10 m (32.8 ft)	1 m (3.3 ft)	3 m (9.8 ft)	5 m (16.4 ft)	
		BNC	BNC	BNC	BNC	BNC	BNC	BNC	BNC	BNC	BNC	BNC	DIN	DIN	DIN/Braun	DIN/Braun	BNC	BNC	BNC	BNC	DIN	DIN	DIN, banana	DIN, banana	DIN, banana	DIN, banana	DIN, banana	DIN, banana	DIN, banana
ISM	pH	pH/ORP ISM (1-wire)	•	•	•	•	•	•	•	•	•																		
	DO/O ₂	DO ISM (1-wire)	•	•	•	•	•	•	•	•	•																		
		InPro 6850 i	•	•	•	•	•	•	•	•	•																		
		InPro 6900 i	•	•	•	•	•	•	•	•	•																		
		InPro 6950 i	•	•	•	•	•	•	•	•	•																		
		O ₂ Gas ISM (1-wire)	•	•	•	•	•	•	•	•	•																		
Cond CO ₂	InPro 5000 i	•	•	•	•	•	•	•	•	•																			
	InPro 7000 i	•	•	•	•	•	•	•	•	•																			
Analog Sensors	pH	InPro 2000															•	•	•	•	•	•	•	•	•	•	•		
		InPro 3100/UD																•	•	•	•	•	•	•	•	•	•	•	
		InPro 3250/SG																•	•	•	•	•	•	•	•	•	•	•	
		InPro 3251																•	•	•	•	•	•	•	•	•	•	•	
		InPro 3252																•	•	•	•	•	•	•	•	•	•	•	
		InPro 3253/SG																•	•	•	•	•	•	•	•	•	•	•	
		InPro 3300																•	•	•	•	•	•	•	•	•	•	•	
		InPro 4010																•	•	•	•	•	•	•	•	•	•	•	•
		InPro 4260/SG																•	•	•	•	•	•	•	•	•	•	•	•
		InPro 4262																•	•	•	•	•	•	•	•	•	•	•	•
		InPro 4501																•	•	•	•	•	•	•	•	•	•	•	•
		InPro 4550																•	•	•	•	•	•	•	•	•	•	•	•
		InPro 4800/SG																•	•	•	•	•	•	•	•	•	•	•	•
		InPro 4801 SG																•	•	•	•	•	•	•	•	•	•	•	•
		InPro 4802																•	•	•	•	•	•	•	•	•	•	•	•
	Puncture																•	•	•	•	•	•	•	•	•	•	•	•	
	DO/O ₂	InPro 6050																•	•	•	•	•	•	•	•	•	•	•	
		InPro 6800																•	•	•	•	•	•	•	•	•	•	•	
		InPro 6800 GAS																•	•	•	•	•	•	•	•	•	•	•	
		InPro 6810																•	•	•	•	•	•	•	•	•	•	•	
		InPro 6820																•	•	•	•	•	•	•	•	•	•	•	
		InPro 6830																•	•	•	•	•	•	•	•	•	•	•	
		InPro 6900																•	•	•	•	•	•	•	•	•	•	•	
		InPro 6910																•	•	•	•	•	•	•	•	•	•	•	•
		InPro 6950																•	•	•	•	•	•	•	•	•	•	•	•
		InPro 6950 GAS																•	•	•	•	•	•	•	•	•	•	•	•
	Conductivity CO ₂	InPro 5000																•	•	•	•	•	•	•	•	•	•	•	
InPro 7000																	•	•	•	•	•	•	•	•	•	•	•		
InPro 7001																	•	•	•	•	•	•	•	•	•	•	•		
InPro 7002																	•	•	•	•	•	•	•	•	•	•	•		
InPro 7005																	•	•	•	•	•	•	•	•	•	•	•		
InPro 7108																	•	•	•	•	•	•	•	•	•	•	•		
Conv.	pH	DXK																											
	DPA																												
	DPAS																•	•	•	•	•	•	•	•	•	•	•		

Order Number
 55 902 189
 59 902 167
 59 902 183
 59 902 213
 52 300 230
 52 300 204
 52 300 303
 52 300 394
 59 902 395
 59 902 188
 59 909 838
 59 902 94
 59 902 214
 59 902 319
 59 902 165
 59 902 191
 59 902 211
 59 902 208
 52 300 107
 52 300 108
 52 300 09
 52 300 110
 52 300 210
 52 300 211
 52 300 212
 52 300 213
 52 300 186
 52 300 187
 52 300 328

For other available cables, please check with your METTLER TOLEDO representative.

-40 to 135 °C/
-40 to 275 °F

VarioPin (VP) Cables				VarioPin (VP) for InPro 3300 (ISFET)				Cables with Type 82 Connector				Conductivity VP Sensor Cables				AS9 Cables with S7 or S8 Connector				
Termination	Length	Termination	Length	Termination	Length	Termination	Length	Termination	Length	Termination	Length	Termination	Length	Termination	Length	Termination	Length			
Tinned Ends	1 m (3.3 ft)	Tinned Ends	3 m (9.8 ft)	Tinned Ends	3 m (9.8 ft)	Tinned Ends	1 m (3.3 ft)	Tinned Ends	1.5 m (4.9 ft)	Tinned Ends	1 m (3.3 ft)	Tinned Ends	1 m (3.3 ft)	Tinned Ends	1 m (3.3 ft)	Tinned Ends	1 m (3.3 ft)	pH/ORP ISM (1-wire)		
Tinned Ends	3 m (9.8 ft)	Tinned Ends	5 m (16.4 ft)	Tinned Ends	3 m (9.8 ft)	Tinned Ends	3 m (9.8 ft)	Tinned Ends	3 m (9.8 ft)	Tinned Ends	3 m (9.8 ft)	Tinned Ends	3 m (9.8 ft)	Tinned Ends	3 m (9.8 ft)	Tinned Ends	3 m (9.8 ft)	DO ISM (1-wire)		
Tinned Ends	5 m (16.4 ft)	Tinned Ends	10 m (32.8 ft)	Tinned Ends	5 m (16.4 ft)	Tinned Ends	5 m (16.4 ft)	Tinned Ends	4.5 m (14.8 ft)	Tinned Ends	5 m (16.4 ft)	Tinned Ends	5 m (16.4 ft)	Tinned Ends	5 m (16.4 ft)	Tinned Ends	5 m (16.4 ft)	InPro 6850 i		
Tinned Ends	10 m (32.8 ft)			Tinned Ends	10 m (32.8 ft)	Tinned Ends	10 m (32.8 ft)	Tinned Ends	7.5 m (24.6 ft)	Tinned Ends	10 m (32.8 ft)	Tinned Ends	10 m (32.8 ft)	Tinned Ends	10 m (32.8 ft)	Tinned Ends	10 m (32.8 ft)	InPro 6900 i		
				Tinned Ends	3 m (9.8 ft)	Tinned Ends	3 m (9.8 ft)	Tinned Ends	15 m (49.2 ft)	Tinned Ends	15 m (49.2 ft)	Tinned Ends	15 m (49.2 ft)	Tinned Ends	15 m (49.2 ft)	Tinned Ends	15 m (49.2 ft)	InPro 6950 i		
				Tinned Ends	5 m (16.4 ft)	Tinned Ends	5 m (16.4 ft)	Tinned Ends	25 m (82.0 ft)	Tinned Ends	25 m (82.0 ft)	Tinned Ends	25 m (82.0 ft)	Tinned Ends	25 m (82.0 ft)	Tinned Ends	25 m (82.0 ft)	O ₂ Gas ISM (1-wire)		
				Tinned Ends	10 m (32.8 ft)	Tinned Ends	10 m (32.8 ft)	Tinned Ends	30 m (98.4 ft)	Tinned Ends	30 m (98.4 ft)	Tinned Ends	30 m (98.4 ft)	Tinned Ends	30 m (98.4 ft)	Tinned Ends	30 m (98.4 ft)	InPro 5000 i		
																		InPro 7000 i		
																		InPro 2000		
																		InPro 3100		
																		InPro 3250		
																		InPro 3251		
																		InPro 3252		
																		InPro 3253 SG		
																		InPro 3300		
																		InPro 4010		
																		InPro 4260		
																		InPro 4262		
																		InPro 4501		
																		InPro 4550		
																		InPro 4800		
																		InPro 4801 SG		
																		InPro 4802		
																		Puncture		
																		InPro 6050		
																		InPro 6800		
																		InPro 6800 GAS		
																		InPro 6810		
																		InPro 6820		
																		InPro 6830		
																		InPro 6900		
																		InPro 6910		
																		InPro 6950		
																		InPro 6950 GAS		
																		InPro 5000		
																		InPro 7000		
																		InPro 7001		
																		InPro 7002		
																		InPro 7005		
																		InPro 7108		
																		DXK		
																		DXK		
																		DPA		
																		DPAS		

52-300-111
52-300-112
52-300-113
52-300-114

52-300-313
52-300-314
52-300-315
52-300-404
52-300-A05
52-300-406

59-906-837
59-906-839
59-906-841
59-906-842
59-906-844

58-080-201
58-080-202
58-080-203
58-080-204
58-080-205
58-080-206
58-080-207

59-902-215
59-902-268
59-902-297
59-902-318
59-902-246
59-902-269
59-902-319
59-902-243
59-902-266
59-902-290

Cables

AK9	Order Number
CABLE, AK9/1M COAX/TINNED	59 902 167
CABLE, AK9/3M COAX/TINNED	59 902 193
CABLE, AK9/5M COAX/TINNED	59 902 213
CABLE, AK9/10M COAX/TINNED	59 902 230
CABLE, AK9/15M COAX/TINNED	53 600 145
CABLE, AK9/20M COAX/TINNED	52 300 204
CABLE, AK9/30M COAX/TINNED	52 300 393
CABLE, AK9/50M COAX/TINNED	52 300 394
CABLE, AK9/80M COAX/TINNED	52 300 395
CABLE, AK9/3M-ST-TRIAX7	59 902 197
CABLE, AK9/15M TRIAX/NO CONNECTOR	53 000 480
CABLE, AK9/1M COAX/BNC	59 902 168
CABLE, AK9/2M COAX/BNC	59 909 838
CABLE, AK9/3M COAX/BNC	59 902 194
CABLE, AK9/5M COAX/BNC	59 902 214
CABLE, AK9/10M COAX/BNC	53 000 477
CABLE, AK9/1M COAX/DIN	59 902 165
CABLE, AK9/3M COAX/DIN	59 902 191
CABLE, AK9/5M COAX/DIN	59 902 211
CABLE, AK9/10M HT COAX/TINNED	59 902 234
CABLE, AK9/1M COAX/DIN SHORT	59 902 188
CABLE, AK9/3M COAX/DIN SHORT/BRAUN	59 902 208
CABLE, AK9/10M COAX/DIN/BRAUN	53 000 479
CABLE, AK9/40IN TRIAX/TURCK (PH)	53 600 139
CABLE, AK9/40IN TRIAX/TURCK (ORP)	53 600 140
ISM Extension Cable/3m	52 004 012
InPro 6960i/6970i Optical Oxygen & InPro 5500i CO₂ Sensor Cables	
CABLE, M12,5-Pin,RS485,2m	52 300 379
CABLE, M12,5-Pin,RS485,5m	52 300 380
CABLE, M12,5-Pin,RS485,10m	52 300 381
CABLE, M12,5-Pin,RS485,15m	52 206 422
CABLE, M12,5-Pin,RS485,25m	52 206 529
CABLE, M12,5-Pin,RS485,50m	52 206 530
UniCond ISM Sensor Cables	
CABLE, ISM 4 WIRE 1 FT	58 080 270
CABLE, UNICOND 4-WIRE 5 FT (1.5m)	58 080 271
CABLE, UNICOND 4-WIRE 10 FT (3m)	58 080 272
CABLE, UNICOND 4-WIRE 15 FT (4.5m)	58 080 273
CABLE, UNICOND 4-WIRE 25 FT (7.6m)	58 080 274
CABLE, UNICOND 4-WIRE 50 FT (15.2m)	58 080 275
CABLE, UNICOND 4-WIRE 100 FT (30.5m)	58 080 276
CABLE, UNICOND 4-WIRE 150 FT (45.7m)	58 080 277
CABLE, UNICOND 4-WIRE 200 FT (61m)	58 080 278
CABLE, UNICOND 4-WIRE 300 FT (91m)	58 080 279

AS7 Cables with S7 Connector	Order Number
CABLE,AS7/2m-ST-coax2.8/-15.30	59 909 345
CABLE,AS7/1M/BNC	53 000 482
VP6 Cables (-30 to 80°C / -22 to 176°F)	
CABLE,VP6-ST/1M	52 300 107
CABLE,VP6-ST/3M	52 300 108
CABLE,VP6-ST/5M	52 300 109
CABLE,VP6-ST/10M	52 300 110
CABLE,VP-ST/15M	52 300 144
CABLE,VP-ST/20M	52 300 141
CABLE,VP-ST/25M	53 600 099
CABLE,VP6-ST/1M/BNC	52 300 210
CABLE,VP6-ST/3M/BNC	52 300 211
CABLE,VP6-ST/5M/BNC	52 300 212
CABLE,VP6-ST/10M/BNC	52 300 213
CABLE,VP6-ST/1M/DIN/BANANA X 2 FOR 1120/1	52 300 186
CABLE,VP6-ST/3M/DIN/BANANA X 2 FOR 1120/1	52 300 187
CABLE,VP6-ST/5M/DIN/BANANA X 2 FOR 1120/1	52 300 328
ADAPTER,VP SOCKET TO T82 CABLE	52 200 939
CABLE,VP-ST EXTENSION/3M	52 300 268
CABLE,VP-ST EXTENSION/5M	52 300 269
CABLE,VP-ST/3M/RT ANGLE	53 600 070
CABLE,VP-ST/5M/RT ANGLE	53 600 072
CABLE,VP-ST/10M/RT ANGLE	53 600 073
High Temp VP6 Cables (-40 to 135°C / -40 to 275°F)	
CABLE,VP6-HT/1M	52 300 111
CABLE,VP6-HT/3M	52 300 112
CABLE,VP6-HT/5M	52 300 113
CABLE,VP6-HT/10M	52 300 114
CABLE,VP6-HT/15M	52 300 237
CABLE,VP6-HT/20M	53 600 118
VP6 Cables for InPro 3300 ISFET (non-M400)	
CABLE,VP-ST/ISFET/3M	52 300 313
CABLE,VP-ST/ISFET/5M	52 300 314
CABLE,VP-ST/ISFET/10M	52 300 315
VP6 Cables for InPro 3300 ISFET/M400	
CABLE,VP6-ST/ISFET/M400/3M	52 300 404
CABLE,VP6-ST/ISFET/M400/5M	52 300 405
CABLE,VP6-ST/ISFET/M400/10M	52 300 406

Cables

VP8 Cables (-30 to 60°C / -22 to 176°F)	Order Number
CABLE,VP8-ST/1M	52 300 353
CABLE,VP8-ST/3M	52 300 354
CABLE,VP8-ST/5M	52 300 355
CABLE,VP8-ST/10M	52 300 356
CABLE,VP8-ST/15M	52 300 357
CABLE,VP8-ST/20M	52 300 358
CABLE,VP8-ST/35M	52 300 359
CABLE,VP8-ST EXTENSION 3M	52 300 365
CABLE,VP8-ST EXTENSION 5M	52 300 366
CABLE,VP-8/1M/FEMALE VP	30 094 370
CABLE,VP-8/3M/FEMALE VP	30 094 371
High Temp VP8 Cables (-40 to 135°C / -40 to 275°F)	
CABLE,VP8-HT/1M	52 300 360
CABLE,VP8-HT/3M	52 300 361
CABLE,VP8-HT/5M	52 300 362
CABLE,VP8-HT/10M	52 300 363
CABLE,VP8-HT/15M	52 300 364
Conductivity VP Sensor Cables	
COND,PATCHCORD-VP, 5 FT	58 080 201
COND,PATCHCORD-VP, 10 FT	58 080 202
COND,PATCHCORD-VP, 15 FT	58 080 203
COND,PATCHCORD-VP, 25 FT	58 080 204
COND,PATCHCORD-VP, 50 FT	58 080 205
COND,PATCHCORD-VP, 75 FT	58 080 206
COND,PATCHCORD-VP, 100 FT	58 080 207
GPro500 Cables	
Cable GPro500 ATEX FM 5m	30 077 735
Cable GPro500 ATEX FM 15m	30 077 736
Cable GPro500 ATEX FM 25m	30 077 737

Cables with Type 82 Connector	Order Number
CABLE,O2/1M/TINNED END	59 906 837
CABLE,O2/3M/TINNED END	59 906 839
CABLE,O2/5M/TINNED END	59 906 841
CABLE,O2/10M/TINNED END	59 906 842
CABLE,O2/20M/TINNED END	59 906 844
CABLE,O2/3M/LEMO 3	59 906 859
CABLE,O2/1M/BNC	59 906 862
CABLE,O2/3M/BNC	59 906 863
ADAPTER, T82 SOCKET TO VP CABLE	52 200 940
AS9 Cables with S7 or S8 Connector	
CABLE,AS9/1M COAX/DIN	59 902 243
CABLE,AS9/1M COAX/TINNED	59 902 245
CABLE,AS9/1M COAX/BNC	59 902 246
CABLE,AS9/1M	59 902 245
CABLE,AS9/3M COAX/TINNED	59 902 268
CABLE,AS9/3M COAX/BNC	59 902 269
CABLE,AS9/5M COAX/TINNED	59 902 292
CABLE,AS9/5M COAX/BNC	59 902 291
CABLE,AS9/5M TRIAX/TINNED	59 902 293
CABLE,AS9/10M COAX/TINNED	59 902 318
CABLE,AS9/10M COAX/BNC	59 902 319
Turbidity Cables	
KIT,CABLE,TURBIDITY, 3M	52 800 228
KIT,CABLE,TURBIDITY, 5M	52 800 229
KIT,CABLE,TURBIDITY, 6M	52 800 230
KIT,CABLE,TURBIDITY, 10M	52 800 231
KIT,CABLE,TURBIDITY, 15M	52 800 232
KIT,CABLE,TURBIDITY, 20M	52 800 233
KIT,CABLE,TURBIDITY, 25M	52 800 234
KIT,CABLE,TURBIDITY, 30M	52 800 235
KIT,CABLE,TURBIDITY, 75M	52 800 177
COUPLINGS FOR TURB EXT CABLES (two included in every kit)	52 800 240
COUPLING BOX, IP65/NEMA 4X, TURB	52 800 241
ADAPTER, SWAGELOCK, 1/2"NPT	52 800 242
CABLE,TURBIDITY,RS 485, 5M	52 800 979
CABLE,TURBIDITY,RS 485, 10M	52 800 981
CABLE,TURBIDITY,RS 485, 20M	52 801 005

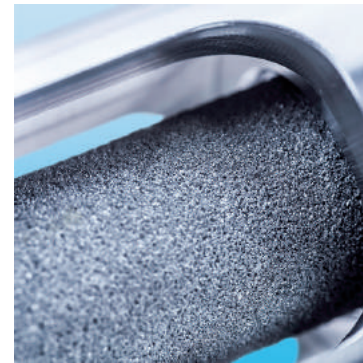
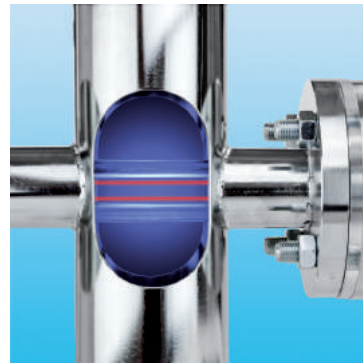
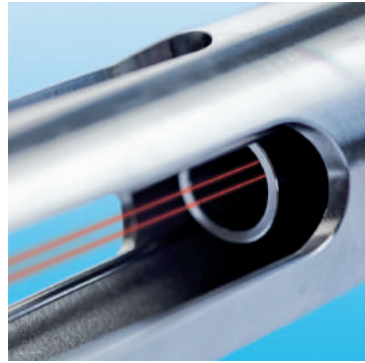

Gas Analytics Measurement Solutions for Industrial Applications

Gas Analyzers Measure Where It Really Matters

Monitoring and controlling the level of harmful or explosive gases in your process is key to ensuring the safety of the environment, people, assets and increasing process efficiency. METTLER TOLEDO's unique range of gas analysis solutions gives you the power to decide where to measure, everywhere it matters.

Based on long-standing field experience in analytical solutions for liquid measurement, METTLER TOLEDO has developed systems for gas analysis that offer:

- **In situ and in-line capability:** our systems are built to measure, right there where you need to measure
- **Low cost of ownership:** outstanding measurement performance without the drawback of heavy maintenance
- **Ruggedness and long-term stability** for continuous use in the harshest environments.

The best technology for the job

METTLER TOLEDO's choice of technologies for gas measurement all feature the ability to measure in situ, without the need for gas sampling or conditioning.

- GPro® 500 **Tunable Diode Laser (TDL)** analyzers provide the highest level of reliability and fastest response time in process control and safety applications.
- Membrane covered InPro **amperometric oxygen sensors** are largely

insensitive to moisture and dust: they are ideally suited for inerting and blanketing applications.

TDL: Laser-sharp view into your process

With TDL absorption spectroscopy, a diode laser with a highly specific and extremely narrow emission wavelength is used to resolve single absorption lines of the gas species to be measured. The absorption lines are carefully selected to avoid cross-interference from other background gases. Using direct absorption spectroscopy, a spectrum is taken and compared with spectral reference data stored in the on-board database for any given temperature and pressure. The concentration of the gas is then calculated, and any inconsistency between reference data and measurement will trigger an alarm.

Process adaptations that fit anywhere

Many users want to reap the benefits of interference-free, drift-free TDL tech-

nology for better process control and lower maintenance costs. However, for reliable measurement with a TDL, necessary framework conditions such as minimum optical path length, availability of purge gas supply, or high dust load in a process can sometimes get in the way. Acknowledging these constraints, METTLER TOLEDO has developed specific adaption solutions to substantially increase the coverage of possible TDL applications.

The new wafer-type adaption allows cross-section installation down to DN50 (2") pipes with no flow restriction and minimum pipe work required. Further, static process gas conditions are not an obstacle to the GPro 500 with the availability of the new process purge-free probe for inertization and blanketing applications. Finally, the filter probe is ideal for measurement in high-dust applications where cross-stack-type TDLs typically fail due to the loss of signal intensity.

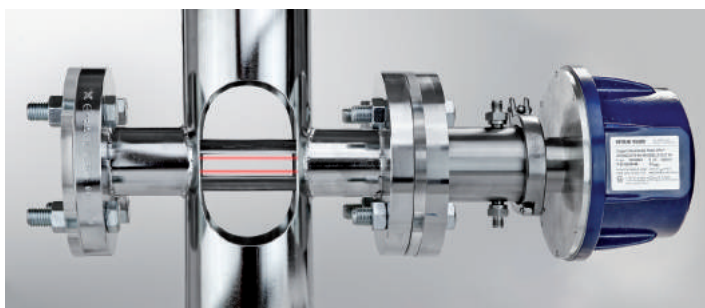

New gases, new opportunities for process and combustion applications:

Oxygen:

- Blanketing and inertization
- Combustion control
- Reformers
- Chlorination
- Flare stacks
- Thermal oxidizer
- Vapor recovery
- Formaldehyde

CO:

- Combustion
- ESP filter
- CO boiler
- FCC units

CO₂:

- FCC units
- Ethylene oxide (EO)
- Ethylene
- PTA plant

- Syngas

- Ammonia
- Fired heaters
- Process heaters
- Carbon black
- Ethylene
- Hydrogen production

CH₄:

- Syn gas

CO/CH₄:

- Combustion

H₂O:

- Chlorine gas
- H₂ reformer gas
- Tower dryer exhaust

H₂S:

- Sulfur recovery

NH₃:

- Ammonia slip

HCl:

- Stack monitoring



▶ www.mt.com/gas

InPro 6800G/ InPro 6850iG InPro 6900iG InPro 6950iG GPro 500

Industrial Processes	InPro 6800G/ InPro 6850iG	InPro 6900iG	InPro 6950iG	GPro 500
Chemical Industry				
Inerting	•	•	•	•
Blanketing	•	•	•	•
Process / safety				•
Vapor recovery	•	•		•
Thermal oxidizer / process heaters				•
Flare				•
Food and Beverage Industry				
CO ₂ recovery			•	
Petrochemical				
Flue gas				•
Flares				•
Process / safety				•
ESP filters				•
Combustion				•

Application guide for gas analyzers (for more application examples, visit www.mt.com/GPro500-eBook)

Comparison of Oxygen Measurement Technologies Selection Criteria to Help You Choose the Right Tool

There is no single measurement technology that will work for every application. METTLER TOLEDO is dedicated to identifying and offering the best technologies for robust in process gas measurements. For making oxygen measurements, we have two technologies. The following is a general guideline for selecting the best technology. To make the final determination, please contact your local METTLER TOLEDO representative.

Oxygen measurement across the process industries

From preventing the build-up of explosive gas mixtures in chemical processes, to nitrogen blanketing for inhibiting product oxidation, to ensuring carbon dioxide purity in the Food and Beverage industry, measurement of oxygen is a vital element of many industrial processes.

Amperometric

This is an electro-chemical measurement technology housed in a compact package. It is a depleting technology, some maintenance and consumables is required. Chemical interferences are possible; knowledge of the gas composition is required for evaluation. For more information on this technique, refer to the Measurement Theory section of this catalog.

Tunable Diode Laser (TDL)

METTLER TOLEDO's TDL technology is immune to most interferences and the sensor's materials of construction are quite robust. There is no regular maintenance and the sensor is designed for long term continuous operation while

being virtually drift free. TDL is suited for the most challenging and critical applications. The physical package is a bit larger than the amperometric and optical sensors. For more information on this technique, refer to the Measurement Theory section of this catalog.

	Amperometric	TDL Oxygen
Applications	Inerting & Blanketing	Process Control, Safety & Combustion
Flow required	No, great for tank inerting	Certain applications require flow
Range	5-50,000 ppm or 50 ppm to 60%	0.01 – 100%
Max temperature	70 °C (158 °F)	600 °C (1112 °F)
Low pressure	-0.81 bar (-11.8 psig)	-0.9 bar (-13.05 psig)
High pressure	+7.95 bar (115.3 psig)	+9 bar (130.53 psig)
N₂ purging required	No	Sometimes
Maintenance, consumables	Required	No
Capital	\$	\$\$\$
Probe size	Very small, for confined spaces	Larger, for pipes 2" dia. or larger
Hazardous area technique	Intrinsic safety	Explosion proof
Background gas interference	Susceptible to some	None
SIL	No	SIL2 compatible version available
ATEX/FM Approved	Yes	Yes

TDL Gas Analyzers

For Every Installation Location in Your Plant



Standard Purged Wafer Non-Purge Non-Purged with filter and Blow-back Extractive Cross-Pipe

Optical Path Interface	Insertion probe	Flow thru. Body is part of pipeline system	Insertion probe	Insertion probe	Extractive cell	Full diameter
Min Flow Requirement	Yes	Yes	No	Yes	No	Yes
Process Interface/Size	Mounts in pipe 4" diameter or larger	2", 150 lb ANSI or 3", 150 lb ANSI or 4", 150 lb ANSI	Mounts in pipe 4" diameter or larger	Mounts in pipe 4" diameter or larger	N/A	Pipes 1–3 m diameter
Typical Application	Near saturated gas stream e.g. combined gas vent line to destruct unit	Near saturated gas stream e.g. dryer, solvent, vapor recovery	Clean dry gases e.g. Storage tank safety blanket	Dry gases with particulate e.g. Flue gases	Clean dry gases from customer's extractive gas sampling system e.g. marine vapor recovery	Hot, flue gases, e.g. ammonia slip/ducts, and stacks

Transmitter version

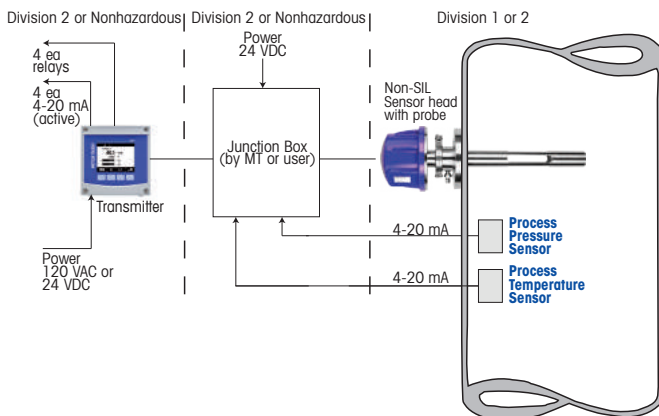

Direct analog out version

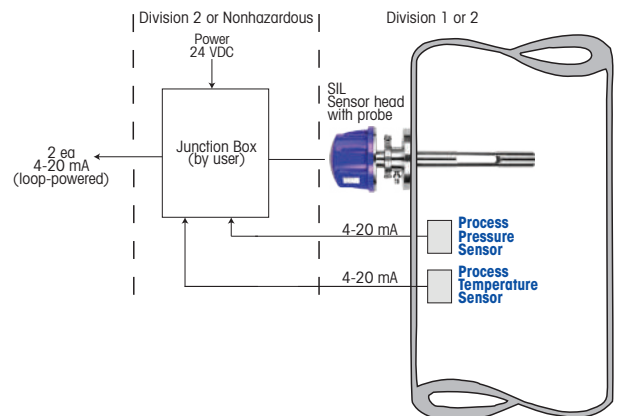

GPro 500 TDL Building Your Measurement System

Selection of Components

For proper operation and optimal performance in your process, each element of your measurement system must be carefully chosen. A complete measurement system requires components including a sensor, junction box, cable and transmitter.

Sensor Selection

METTLER TOLEDO sensors are high performance and long lasting. However, proper selection must be made according to the application and process environment to which it will be exposed.

Basic selection considerations are:

- Gas to be measured
- Measurement range
- Operating temperature/pressure range
- Alarm level
- Accuracy required
- Background gases & concentrations
- Ambient temperature
- Contaminants (particulates, oils, condensate, aerosols)
- Piping/vessel sizes
- Gas stream velocity
- Dust and particle content

The sensor is made up of two significant pieces, as discussed below:

1a. Sensor-Spectrometer Portion (head)

Once it has been determined that we can successfully make the desired measurement, selection of correct head is relatively simple

Choices include:

- Gas to be measured (presently O₂, CO, CO₂, HCl, H₂S, CH₄ CO/CH₄, CH₄, NH₃ and H₂O vapor)
- Safety approval type (FM or ATEX)
- Requirement for SIL2

1b. Sensor – Process Adaption Portion

Upon detailed review of the process conditions and using our many years of experience, we select the best style adaption for the application and the appropriate size.

This is a brief summary of the process adaption styles (each available in various sizes):

- Purged probe
- Non-purged probe
- Non-purged probe with filter and optional blowback
- Wafer
- Extractive
- White cell

In addition to the sensor style and size, other decisions include:

- Seal material (Kalrez® types or graphite)
- Optic material (borosilicate glass, quartz or sapphire)
- Wall thickness (to accommodate wall insulation)
- Process connection size
- Material of construction: 316L stainless steel and C22 Hastelloy are standard; others are available on request.



2. Transmitter Selection

Transmitters are the component that communicates a sensor's readings into displayed measurements. The transmitter also transfers the data to the process control system.

Most users want the convenience of having a local display, multiple analog inputs/outputs and alarms. For these users we select the model M400, Type 3 transmitter. This 4 wire transmitter is ATEX/FM approved for Zone/Division 2 areas, is suitable for indoor or outdoor use and can be powered from AC or DC.

If your site requires a SIL version of the GPro 500, that version does not utilize the separate (M400) transmitter. The SIL version of the GPro 500 has a simple transmitter built into the sensor's head. It does not have the functionality of the M400, it simply has 2 analog (4–20mA) signal outputs (loop powered).

3. Junction Box

The multi-core cable that connects on one end to the GPro 500 head terminates the other end at a junction box that houses a 16 position terminal strip. METTLER TOLEDO offers a junction box or users can provide their own junction box. The junction box needs to be rated for the area where it will be installed.

4. Cable

A multi-core cable is used to connect the GPro 500 head to the junction box. Note: on the FM unit, the cable is shipped loose, the ATEX unit has the cable pre-terminated in the sensor's head.

5. Verification Cell

Although not part of the GPro 500, a verification cell is a useful tool to verify calibration and for troubleshooting.

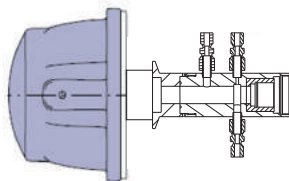

To use the cell, remove the sensor head from the probe and connect the cell to the head using the Tri-Clamp and special gasket. One verification cell can be used for multiple units on the same site. Ambient air can be used as a check gas for the oxygen sensor. To introduce other gases, the cell has inlet and outlet fittings.

6. Diagnostic Software

The MT TDL Suite is PC software with a variety of functions to see into and capture information about the operation of your GPro 500. It is not mandatory to ever use this software but most users find it a powerful tool. The software suite will automatically detect the gas that your unit is designed to measure and will display it appropriately.



7. Thermal Barrier

If the process gas is expected to be at a temperature between 250 °C to 600 °C, a thermal barrier can be used to protect the sensor's electronics. The thermal barrier is effectively a spool piece mounted between the sensor and the sensor head.

GPro 500 Sensor

In Situ Sensor Convenience, with the Power of an Analyzer



Tunable Diode Laser (TDL) measurement technology is recognized for speed and accuracy of measurement, and immunity to background gases. To this, METTLER TOLEDO has added the simplicity of use and low maintenance of in-line sensor design, plus advanced predictive diagnostics. The result is the GPro 500 series, a highly durable line of oxygen sensors for process and safety applications in chemical plant and petrochemical operations.

Specifications

Measurement O₂

Effective path length	Probes: 200, 400, 800 mm (7.87", 15.75", 31.49")
	Water: 50, 80, 100 mm (1.96", 3.15", 3.94")
	Extractive cells: 200, 400, 800 mm, 1 m, 10 m (7.87", 15.75", 31.49", 39.37", 393.70")
Lower detection limit (in 1 meter path length at ambient standard conditions, dry gas, no dust load, in N ₂ background)	100 ppm-v
Measurement range	0–100%
Accuracy	2% of reading or 100 ppm O ₂ , whichever is greater
Linearity	Better than 1%
Resolution	< 0.01% vol O ₂ (100 ppm-v)
Drift	Negligible (< 2% of measurement range between maintenance intervals)
Sampling rate	1 second
Response time (T ₉₀)	O ₂ in N ₂ 21% > 0% in < 2 sec
Warm up time	Typically < 1 minute
Repeatability	± 0.25% of reading or 0.05% O ₂ (whichever is greater)
Process pressure range	0.1 bar – 10 bar (abs)* / 1.45 psi – 145.03 psi (abs)
Process temperature range	0 – 250 °C (32 – 482 °F) Optional (for probe installation) 0 – 600 °C (0 – 1112 °F) with additional thermal barrier

* firmware 6.23 or higher

Features Overview

- One-flange installation without alignment
- In situ measurement without sampling system
- Low cost-of-ownership with virtually no maintenance
- Low purge gas consumption for minimum operating costs
- Large choice of process interface options



Did You Know

Tunable Diode Laser spectrometers are insensitive to background interference from the process gas and moisture, and are largely resistant to heavy dust loads.

▶ www.mt.com/GPro500

Measurement (All measurement specifications with reference to standard conditions T & P with no dust or particulates) and 1 m optical path

	O ₂	CO (ppm)	CO (%)	H ₂ O	H ₂ O ppm	CO ₂ (%)
Effective path length	Probes: 200, 400, 800 mm (7.87", 15.75", 15.75", 31.50"). Wafer Cell: 104 mm, 110 mm, 154 mm, 164 mm, 214 mm (4.09", 4.33", 6.06", 6.46", 8.43") Extractive cells: 200 mm, 400 mm, 800 mm, 1 m, 8 m (7.87", 15.75", 31.50", 39.37", 315")					
Measurement range and standard conditions ¹⁾	0–100%	0–2%	0–100%	0–20%	0–1%	0–100%
Lower Detection Limit ²⁾	100 ppm-v	1 ppm-v	1500 ppm-v	5 ppm-v	1 ppm-v	1000 ppm-v
Accuracy	1% of reading or 100 ppm O ₂ , whichever is greater	2% of reading or 1 ppm, whichever is greater	2% of reading or 1500 ppm, whichever is greater	2 % of reading or 10 ppm, whichever is greater	2% of reading or 1 ppm, whichever is greater	2% of reading or 1000 ppm, whichever is greater
Linearity	Better than 1%	Better than 1%	Better than 1%	Better than 1%	Better than 1%	Better than 1%
Resolution	<0.01% vol O ₂ (100 ppm-v)	1 ppm-v	1500 ppm-v	5 ppm-v	1 ppm-v	1000 ppm-v
Drift	Negligible (<2% of measurement range between maintenance intervals)					
Sampling rate	1 second	1 second	1 second	1 second	1 second	1 second
Response time (T90)	O ₂ in N ₂ 21% >0% in <2 sec	CO in N ₂ 300 ppm-v to 0% in <4 sec	CO in N ₂ 1% to 0% in <4 sec	H ₂ O in N ₂ 1% to 0% in <4 sec	H ₂ O in N ₂ 1% to 0% in <4 sec	CO ₂ in N ₂ 1% to 0% in <4 sec
Warm-up time	Typically <1 hour	Typically <1 hour	Typically <1 hour	Typically <1 hour	Typically <1 hour	Typically <1 hour
Repeatability	±0.25% of reading or 0.05% O ₂ , whichever is greater	±0.25% of reading or 5 ppm-v CO, whichever is greater	±0.25% of reading or 0.75%-v CO, whichever is greater	±0.25% of reading or 50 ppm-v H ₂ O, whichever is greater	±0.25% of reading or 10 ppm-v H ₂ O, whichever is greater	±0.25% of reading or 5000 ppm-v CO ₂ , whichever is greater
Process pressure range	0.1 bar to 10 bar (abs)*/1.45 psi to 145.03 psi (abs)*	0.8 bar to 2 bar (abs)/11.6 psi to 29. psi (abs)	0.8 bar to 1.5 bar (abs)/11.6 psi to 21.7. psi (abs)	0.8 bar to 2 bar (abs)/11.6 psi to 29. psi (abs)	0.8 bar to 5 bar (abs)/11.6 psi to 72.5 psi (abs)	0.8 bar to 2 bar (abs)/11.6 psi to 29 psi (abs)
Process temperature range	0 to +250 °C (+32 to +482 °F) Standard. 0 to +600 °C (0 to +1112 °F) with built in thermal barrier. 0 to +150 °C (+32 to +302 °F) (White cell, PFA, PTFE filter)					
	* firmware 6.23 or higher					

	CO ppm/CH ₄ %	CO ₂ %/CO %	HCl (ppm)	H ₂ S (%)	CH ₄ ppm	NH ₃ ppm
Effective path length	Probes: 200, 400, 800 mm (7.87", 15.75", 15.75", 31.50"). Wafer Cell: 104 mm, 110 mm, 154 mm, 164 mm, 214 mm (4.09", 4.33", 6.06", 6.46", 8.43") Extractive cells: 200 mm, 400 mm, 800 mm, 1 m, 8 m (7.87", 15.75", 31.50", 39.37", 315")					
Measurement range and standard conditions ¹⁾	0–2% (CO) 0–10% (CH ₄)	0–100% (CO ₂ and CO)	0–3%	0–50%	0–1%	0–1%
Lower Detection Limit ²⁾	0–200°C: 1 ppm-v (CO), 5 ppm-v (CH ₄) 200–600°C: 5 ppm-v (CO), 25 ppm-v (CH ₄)	1000 ppm-v (CO ₂) 1500 ppm-v (CO)	0.6 ppm-v	20 ppm-v	1 ppm-v	1 ppm-v
Accuracy	2% of reading or 1 ppm (CO)/25 ppm-v (CH ₄), whichever is greater	2% of reading or 1000 ppm, whichever is greater	2% of reading or 0.6 ppm, whichever is greater	2% of reading or 20 ppm, whichever is greater	2 % or 1 ppm	2 % or 1 ppm
Linearity	Better than 1%	Better than 1%	Better than 1%	Better than 1%	Better than 1%	Better than 1%
Resolution	1 ppm-v (CO) 3 ppm-v (CH ₄)	1000 ppm-v	0.6 ppm-v	20 ppm-v	1 ppm	1 ppm
Drift	Negligible (<2% of measurement range between maintenance intervals)					
Sampling rate	1 second	1 second	1 second	1 second	1 second	1 second
Response time (T90)	CO/CH ₄ in N ₂ 2% to 0% in <4 sec	CO ₂ in N ₂ 1% to 0% in <4 sec	HCl in N ₂ 1% to 0% in <4 sec	H ₂ S in N ₂ 1% to 0% in <4 sec	CH ₄ in N ₂ 1% to 0% in <4 sec	NH ₃ in N ₂ 1% to 0% in <4 sec
Warm-up time	Typically <1 hour	Typically <1 hour	Typically <1 hour	Typically <1 hour	Typically <1 hour	Typically <1 hour
Repeatability	±0.25% of reading or 5 ppm-v CO/500 ppm-v CH ₄ , whichever is greater	±0.25% of reading or 5000 ppm-v CO ₂ or CO, whichever is greater	±0.25% of reading or 3 ppm-v HCl, whichever is greater	±0.25% of reading or 100 ppm-v H ₂ S, whichever is greater	±0.25% of reading or 5 ppm-v CH ₄ , whichever is greater	±0.25% of reading or 5 ppm-v NH ₃ , whichever is greater
Process pressure range	0.8 bar to 2 bar (abs)/11.6 psi to 29 psi (abs)	0.8 bar to 2 bar (abs)/11.6 psi to 29 psi (abs)	0.8 bar to 3 bar (abs)/11.6 psi to 43.5 psi (abs)	0.8 bar to 2 bar (abs)/11.6 psi to 29 psi (abs)	0.8 bar to 3 bar (abs)/11.6 psi to 43.5 psi (abs)	0.8 bar to 3 bar (abs)/11.6 psi to 43.5 psi (abs)
Process temperature range	0 to +250 °C (+32 to +482 °F) Standard. 0 to +600 °C (0 to +1112 °F) with built in thermal barrier. 0 to +150 °C (+32 to +302 °F) (White cell, PFA, PTFE filter)					

¹⁾ Measurement range and standard conditions (ambient temperature and pressure, 1 m path length).²⁾ Lower Detection Limit (in 1 meter path length at ambient standard conditions, dry gas, no dust load, in N₂ background).

Gas Analyzers

Measure Everywhere It Matters

Variant Configurator

Gas Analyzer	GPro 500	A	T	A	O	P	B	K	S	O	2	O	P	D	1	X	S	_	_	/	A	X
30 027 126*, 30 538 717**	GPro 500	Y	Y	Y	Y	Y	Y	Y	Y	Y	Y	Y	Y	Y	Y	Y	Y	Y	Y	/	Y	Y
Hazardous area approvals																						
ATEX/IECEX Ex d		A	T																			
FM Class 1 Div 1		U	S																			
Gases																						
Oxygen				A	O																	
CO				C	O																	
H ₂ O				H	O																	
H ₂ O ppm				H	1																	
CO ₂ %				C	2																	
CO %				C	1																	
CO % + CO ₂ %				C	C																	
CO ppm + CH ₄ %				C	M																	
H ₂ S				S	1																	
HCl ppm				L	O																	
CH ₄ ppm				M	O																	
NH ₃ ppm				N	O																	
Process interfaces																						
Standard Probe purged (SP)						P																
Standard Probe purged twin (SP)						T																
Non-purged Filter Probe (NP)						F																
Non-purged Filter Probe twin (NP)						R																
Non-purged Filter Probe with Blow-back (BP)						B																
Non-purged Filter Probe with Blow-back twin						U																
Wafer (W)						W																
Extractive Cell (E)						E																
Cross-pipe Folded Path (C)						C																
Process optics***																						
Borosilicate						B																
Quartz						Q																
Sapphire						S																
Dual Window Borosilicate						C																
Dual Window Quartz						R																
Dual Window Sapphire						T																
Process sealings***																						
Kalrez® 6375						K																
Graphite						G																
Kalrez® (FDA grade) 6230						F																
Kalrez® 6380						S																
Kalrez® 0090						R																
EPDM FDA						Q																
Wetted materials***																						
1.4404 (equivalent to 316L)									S	O												
Hastelloy C22									C	O												
Optical path probes and extractive cell***																						
200 mm (7.9")											2	0										
400 mm (15.7")											4	0										
800 mm (31.5")											8	0										
1 m (3.3 ft)											0	1										
2 m (6.6 ft)											0	2										
3 m (9.8 ft)											0	3										
4 m (13.1 ft)											0	4										

Variant Configurator (continued)

Gas Analyzer	GPro 500	A	T	A	O	P	B	K	S	O	2	O	P	D	1	X	S	_	_	/	A	X	
30 027 126*, 30 538 717**	GPro 500	Y	Y	Y	Y	Y	Y	Y	Y	Y	Y	Y	Y	Y	Y	Y	Y	Y	Y	/	Y	Y	
5 m (16.4 ft)												0	5										
6 m (19.7 ft)												0	6										
10 m (32.8 ft)												1	0										
None												X	X										
Process connections***																							
DN 50/PN 25																	P	D					
ANSI 2"/300 lbs																	P	A					
DN 50/PN 16																	L	D					
ANSI 2"/150 lbs																	L	A					
DN 80/PN 16																	G	D					
ANSI 3"/150 lbs																	G	A					
DN 100/PN 25																	N	D					
ANSI 4"/300 lbs																	N	A					
ANSI 4"/150 lbs																	M	A					
DN 50/PN 16 and 40																	W	1					
DN 80/PN 16 and 40																	W	2					
DN 100/PN 16																	W	3					
ANSI 2"/150 lbs																	W	4					
ANSI 3"/150 lbs																	W	5					
ANSI 4"/150 lbs																	W	6					
Swagelok 6 mm																	E	M					
Swagelok 1/4"																	E	I					
Wall thickness***																							
100 mm																				1			
200 mm																				2			
300 mm																				3			
None																				X			
Filters**																							
Filter A – 40 µm																				A			
Filter B – 100 µm																				B			
Filter C – 200 µm																				C			
Filter D – 3 µm																				D			
Filter PTFE Membrane																				E			
No Filter																				X			
Add-on modules***																							
None																				X	_	_	/
With Thermal Barrier (up to 600 °C)																				H	_	_	/
2-fold Multireflection Cell																				2	_	_	/
3-fold Multireflection Cell																				3	_	_	/
Cable																							
5 m (16.4 ft)																						A	
15 m (49.2 ft)																						B	
25 m (82.0 ft)																						C	
40 m (131.2 ft)																						D	
None																						X	
Communication interfaces																							
RS 485 (for M400)																						X	
RS 485 and Direct Analog (SIL)																						A	

* 6 weeks delivery time. ** 3 weeks delivery time. *** Other configurations upon request.

InPro 6000 G Sensor Series

Oxygen Control for Your Gas Applications



Features Overview

- True in-line measurement without gas sampling system
- Long lasting and easy to maintain membranes
- Certified for hazardous gaseous and dust areas
- Oxygen measurement is not affected by water, water vapors or most organic solvents

Other Highlights

- Membrane covered amperometric measurement technology allows direct in-line installations
- Sensor can easily be calibrated in air. Costly calibration gases are eliminated

The InPro 6000 G O₂ sensor series for gas measurement provides high operational availability together with excellent measurement performance. Without the need for expensive gas sample conditioning, the sensor can be installed directly in the process, and sensor maintenance or replacement can be performed without process interruption. METTLER TOLEDO offers a unique easy-to-use and reliable solution for challenging applications like N₂ blanketing, inertization and off-gas monitoring in Ex or non-Ex applications.

Specifications

Performance

Operating range	InPro 6800G/6850iG:	0.1 Vol-% O ₂ to 100 Vol-% O ₂
	InPro 6900iG:	50 ppm to 60 Vol-% O ₂
	InPro 6950iG:	5 ppm to 50,000 ppm
Accuracy	InPro 6800G/6850iG:	≤ ± [1 % + 0.1 Vol-%]
	InPro 6900iG:	≤ ± [1 % + 50 ppm]
	InPro 6950iG:	≤ ± [1 % + 5 ppm]
Response time at 25 °C (77 °F) (N ₂ → 15 Vol-% O ₂)		90 % of the signal in < 20
Sensor signal in air at 25 °C (77 °F)	InPro 6800G/6850iG:	50 to 110 nA
	InPro 6900iG:	250 to 500 nA
	InPro 6950iG:	2500 to 6000 nA

Construction

Measuring principle	Amperometric Clark electrode
Cable connection	Analog VarioPin (IP68), Digital K8S (IP68)
Connector design	Straight
Process connection	Pg 13.5
Sensor diameter	12 mm
Sensor body	316L stainless steel C22 (titanium on request)
Membrane material	PTFE/Silicone (reinforced with steel mesh)
Surface roughness of wetted parts	N5/R _a 16 (R _a = 0.4 μm / 16 μin)
O-ring material	Silicone or Kalrez®

Working Conditions

Temperature compensation	Automatic
Measuring temperature range	0 to 70 °C (32 to 158 °F)
Environmental temperature range	–5 to 121 °C (23 to 249.8 °F)
Operating pressure	0.2 to 9 bar (2.9 to 130 psi absolute)
Design pressure	Maximum 12 bar (174 psi absolute)

Certificates and Approvals

METTLER TOLEDO Quality Certificate, EHEDG, FDA/USP Class VI, 3.1, N5/R_a16, ATEX: Ex ia IIC T6/T5/T4/T3 Ga/Gb, Ex ia IIIC T69 °C/T81 °C/T109 °C/T161 °C Da/Db FM: IS Cl. I, II, III, Div 1, GR ABCDEFG/T6*

Intelligent Sensor Management (ISM)

InPro 6000iG sensors with integrated ISM functionality allow Plug and Measure and advanced diagnostics. ISM simplifies the installation, handling and maintenance of measurement equipment. For more information see ISM introduction pages 10–11.

► www.mt.com/O2-gas

Ordering Information

12 mm InPro 6800G Oxygen Sensors	Length	Connector Style	Order Number
InPro 6800G/12/120	120 mm	Straight VP	52 206 425
InPro 6800G/12/220	220 mm	Straight VP	52 206 426
InPro 6800G/12/120/Ka	120 mm	Straight VP	52 206 427
InPro 6800G/12/220/Ka	220 mm	Straight VP	52 206 428
InPro 6800G/12/120/C22	120 mm	Straight VP	52 206 429
InPro 6800G/12/220/C22	220 mm	Straight VP	52 206 430
12 mm InPro 6850iG Oxygen Sensors			
InPro 6850iG/12/120	120 mm	Straight K8S	52 206 431
InPro 6850iG/12/220	220 mm	Straight K8S	52 206 432
InPro 6850iG/12/120/Ka	120 mm	Straight K8S	52 206 433
InPro 6850iG/12/220/Ka	220 mm	Straight K8S	52 206 434
InPro 6850iG/12/120/C22	120 mm	Straight K8S	52 206 435
InPro 6850iG/12/220/C22	220 mm	Straight K8S	52 206 436
12 mm InPro 6900iG Oxygen Sensors			
InPro 6900iG/12/120	120 mm	Straight K8S	52 206 437
InPro 6900iG/12/220	220 mm	Straight K8S	52 206 438
InPro 6900iG/12/120/Ka	120 mm	Straight K8S	52 206 439
InPro 6900iG/12/220/Ka	220 mm	Straight K8S	52 206 440
12 mm InPro 6950iG Oxygen Sensors			
InPro 6950iG/12/120	120 mm	Straight K8S	52 206 443
InPro 6950iG/12/220	220 mm	Straight K8S	52 206 444

Consumables

Designation	Order Numbers			
	InPro 6800G	InPro 6850iG	InPro 6900iG	InPro 6950iG
Membrane body, single T-Type	52 201 151	52 206 453	52 206 459	52 206 465
Membrane body, single T-Type Ka (Kalrez® O-ring)	52 201 158	52 206 455	52 206 461	–
Membrane body, single T-Type C22 (Kalrez® O-ring, wetted part C22)	52 201 163	52 206 457	–	–
Membrane kit T-Type*	52 201 149	52 206 454	52 206 460	52 206 466
Membrane kit T-Type Ka**	52 201 159	52 206 456	52 206 462	–
Membrane kit T-Type C22***	52 201 164	52 206 458	–	–
Replacement anode/cathode assembly	52 206 449	52 206 450	52 206 451	52 206 452
O ₂ electrolyte pack (3 × 25 ml)	30 298 424	30 298 424	–	–
InPro 6900 electrolyte pack (3 × 5 ml)	–	–	30 298 425	–
InPro 6950 electrolyte pack (3 × 5 ml)	–	–	–	30 298 426

* 4 membranes, 1 O-ring set silicone, 25 ml electrolyte (InPro 69XXiG models: 2 × 5 ml electrolyte), wetted parts SS 316L

** 4 membrane, 1 O-ring set Kalrez®, 25 ml electrolyte (InPro 69XXiG models; 2 × 5 ml electrolyte), wetted parts SS 316L

*** 4 membranes, 1 O-ring set Kalrez®, 25 ml electrolyte, wetted parts C22 (Hastelloy)

Accessories

Designation	Order Number
O ₂ Sensor Master digital ISM	52 206 329
InPro 6800 Sensor Master	52 200 892



Did You Know

The InPro 6000G with ISM series feature a built-in electrolyte level monitor that signals the user when refilling is required.

O₂ sensor master



Replacement anode/cathode assembly of InPro 6950iG



Membrane Body InPro 6800G



Membrane Body InPro 6850iG

Suitable Housings

	p.
InFit 761 e.....	112
InFlow	122
InTrac 777 e.....	127
InTrac 797 e.....	128
InTrac 781	129



Process Analytics Measurement Solutions for Industrial and Pure Water Applications

Conductivity/Resistivity Systems

When Optimal Performance Is Essential

Electrolytic conductivity is a widely used analytical parameter for water purity analysis, monitoring of reverse osmosis, cleaning procedures, control of chemical processes, and in industrial wastewater.

Three commonly used techniques

Electrolytic conductivity is a measure of the total ionic content of a solution. There are three main methodologies to measure conductivity:

- 2-electrode sensors are for measurements in high purity water and relatively low conductivity ranges
- 4-electrode sensors are for mid to high ranges. They are more resistant to fouling than 2-electrode designs
- Inductive sensors cover mid to very high conductivity ranges, and are particularly resistant to fouling.

METTLER TOLEDO offers all three methodologies.

2-electrode sensor design

An AC voltage is applied across the two electrodes, and the resistance between them is measured. The built-in temperature sensor provides fast accurate measurement. The cell geometry and the high solution resistance allow for very accurate and precise conductivity determination.

Sensors are used for water conditioning and purification stages where they are capable of detecting minute levels of impurities in ultrapure water.

4-electrode sensor design

An AC voltage is applied across the two outside electrodes. The principle is to measure the voltage drop across the two inner electrodes. Therefore, polarization errors are eliminated. Since this technique measures potential drop, the measurement remains accurate. It permits easier in-line cleaning and it can be installed in smaller piping than inductive sensors.

These sensors are used for concentration measurement of acids, alkalis, and salt process streams.



58 031 404



58 031 242



58 031 423



58 031 201

Application guide for conductivity sensors

Thornton sensors
 NPT titanium 0.1 cm² sensors
 Sanitary 316L SS 0.1 cm² sensors
 NPT CPVC & PEEK 4-E sensors
 Sanitary PEEK 4-E sensors

Where to use	NPT titanium 0.1 cm ² sensors	Sanitary 316L SS 0.1 cm ² sensors	NPT CPVC & PEEK 4-E sensors	Sanitary PEEK 4-E sensors
Pure and ultrapure water	•	•		
Sanitary		•		•
Water purification	•			
SIP		•		•
Industrial wastewater			•	
Medium/high conductivity			•	•
Aggressive chemicals			•	
Chemical applications			•	
Pharmaceutical water		•		
High conductivity			•	•
Chemical concentration			•	•

UniCond® Conductivity/Resistivity Sensors with ISM

The UniCond conductivity/resistivity sensor advancement integrates the measuring circuit and the physical sensor into a single unit. UniCond conductivity/resistivity sensors provide exceptionally wide measurement ranges due to their advanced built-in measuring circuit. The on-board measuring circuit eliminates interference from lead wire resistance and capacitance. Only digital signals go back to the transmitter. The UniCond design mitigates the effects of polarization, enabling the upper range of the conductivity sensor to be greatly expanded. UniCond 2-electrode sensors provide the ability to accurately measure from ultrapure water to brackish water (up to 50,000 µS/cm) with a single integrated sensor, greatly simplifying water treatment instrumentation. UniCond 4-electrode sensors measure up to 1 S/cm.

Inductive Sensors (see page 70, 78 – 79)

Continuous conductivity monitoring of pharmaceutical waters

USP guideline <645> sets a standard for the quality assessment of USP waters based on measurement of the electrolytic conductivity. There is a 3-stage test in which stage 1 allows on-line, non-temperature compensated conductivity measurement. There are specific requirements for the sensors and transmitters (see table below). Thornton instruments fulfill all these and other pharmacopeia requirements. In addition, Thornton instruments provide USP and EP setpoints for convenience.

Specification	USP <645>
Conductivity sensor and cell constant accuracy	Verify cell constant within ± 2 % using a reference solution
Resistance measurement circuit	NIST traceable 0.1 % precision resistors in place of sensor
Instrument resolution	0.1 µS/cm
Instrument accuracy at 1.3 µS/cm	0.1 µS/cm
Temperature compensation	Must be read uncompensated
Instrument dynamic range	10 ²

METTLER TOLEDO instruments meet USP <645> and other pharmacopeia water conductivity requirements

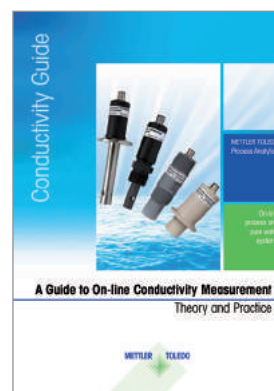

Find out more in our comprehensive conductivity theory guide at www.mt.com/conductivity-guide

UniCond Conductivity/Resistivity Sensors with ISM Certified Calibration for Compliance



ISM®

UniCond conductivity/resistivity sensors provide exceptionally wide measurement ranges due to their advanced built-in measuring circuit. The on-board measuring circuit eliminates interference from leadwire resistance and capacitance. Only digital signals go back to the transmitter. Advanced measuring techniques further contribute to superior accuracy over the expanded range. ISM technology features pre-calibration Plug and Measure capabilities for fast, compliant start-up.

Specifications

Accuracy	0.01 cm ⁻¹ sensor: ± 1 %
	0.1 cm ⁻¹ sensors: ± 1 % for 0.02–5,000 µS/cm; ± 3 % > 5,000 µS/cm
	4-E sensors: ± 4 %
Repeatability	± 0.25 %; ± 2 % for 4-E sensors
Temperature sensor	Pt 1000 RTD, IEC 60751, Class A, with NIST-traceable calibration
Temperature accuracy	± 0.1 °C at 25 °C; ± 0.5 °C for 4-E sensors
Maximum cable length	91 m (300 ft)
Finish (Sanitary 0.1 cm ⁻¹ sensors)	Ra 0.38 micrometers (15 microinches), 316 L SS is electropolished
Insulator material	PEEK except for the CPVC sensors
Response time	90 % of value in < 5 s
Connector	IP 65, mates with 58 080 27X series cable

Features Overview

- Plug and Measure functionality
- Integral high-performance measuring circuit
- Robust digital output signal
- Calibration data stored internally
- Measuring circuit and system calibration can be performed in-line
- Simple compliance

Other Highlights

- Extremely wide rangeability: ultrapure to sea water
- Highest accuracy
- NPT and Tri-Clamp connections



▶ www.mt.com/UniCond

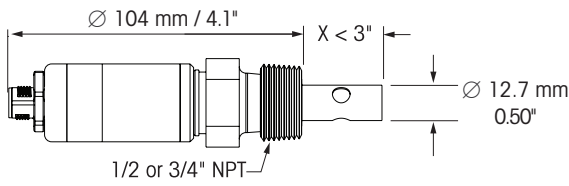

UniCond NPT 0.01 and 0.1 constant conductivity sensors

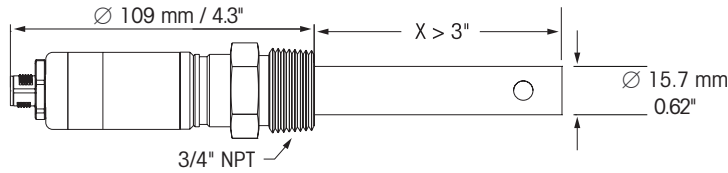

UniCond NPT 0.1 constant conductivity sensors

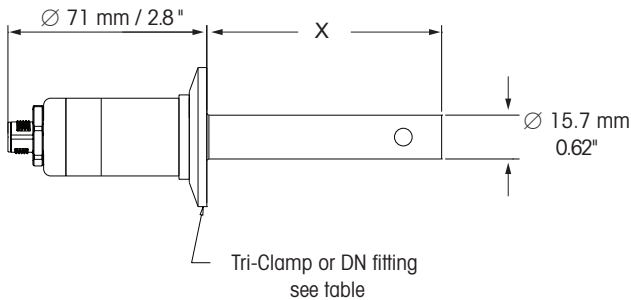

UniCond sanitary 0.1 constant conductivity sensor

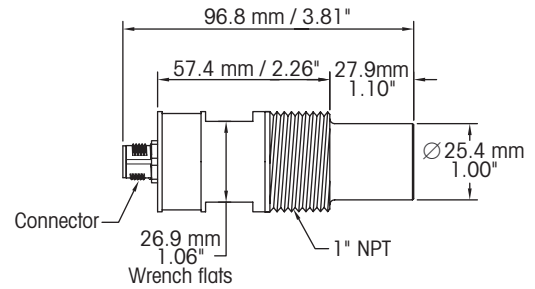

UniCond NPT PEEK conductivity sensors

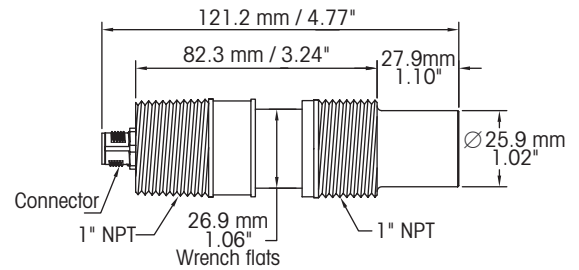

UniCond NPT CPVC conductivity sensors

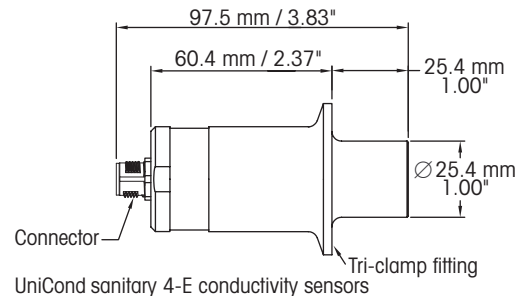

UniCond sanitary 4-E conductivity sensors

Ordering Information

Description							Order Number
Fitting	Insertion Length "X" mm (inch)	Fitting/Body material	Range ($\mu\text{S}/\text{cm}$)*	Cell Const. (cm^{-1})	Electrode Material	Max Pressure at Temp bar (psig) at °C (°F)	
3/4" NPTM	34 (1.35)	PTFE/SS	0.01–50,000	0.1	Titanium	17 (250) at 93 (200)	58 031 404
3/4" NPTM	132 (5.19)	PTFE/SS	0.01–50,000	0.1	Titanium	17 (250) at 93 (200)	58 031 409
3/4" NPTM	34 (1.35)	PTFE/SS	0.01–50,000	0.1	Monel	17 (250) at 93 (200)	58 031 407
3/4" NPTM	132 (5.19)	PTFE/SS	0.01–50,000	0.1	Monel	17 (250) at 93 (200)	58 031 408
1/2" NPTM	29 (1.14)	PTFE/SS	0.01–50,000	0.1	Titanium	17 (250) at 93 (200)	58 031 406
3/4" NPT	60 (2.38)	PTFE/SS	0.001–500	0.01	Titanium	17 (250) at 93 (200)	58 031 410
1 1/2" Tri-Clamp	86 (3.38)	Titanium	0.01–50,000	0.1	Titanium		58 031 413†
1 1/2" Tri-Clamp	55 (2.17)	316L SS	0.01–3,000	0.1	316L SS	14 (203) at 130 (266)	58 031 412†
1 1/2" Tri-Clamp	86 (3.38)	316L SS	0.01–3,000	0.1	316L SS	& 31 (450) at 25 (77)	58 031 414†
2" Tri-Clamp	105 (4.13)	316L SS	0.01–3,000	0.1	316L SS		58 031 415†
1" NPTM	28 (1.1)	PEEK	10–1,000,000	4-E	Hastelloy	7 (100) at 93 (200) 14 (200) at 25 (77)	58 031 421
1" NPTM	28 (1.1)	CPVC	10–1,000,000	4-E	316L SS	3.5 (50) at 80 (176)	58 031 422
1" NPTM	28 (1.1)	CPVC	10–1,000,000	4-E	Hastelloy	7 (100) at 25 (77)	58 031 423
1 1/2" Tri-Clamp	25 (1.0)	PEEK	10–1,000,000	4-E	316L SS		58 031 424†
2" Tri-Clamp	25 (1.0)	PEEK	10–1,000,000	4-E	316L SS	4.8 (70) at 140 (284)	58 031 425†
1 1/2" Tri-Clamp	25 (1.0)	PEEK	10–1,000,000	4-E	Hastelloy	14 (200) at 50 (122)	58 031 426†

* Megohm-cm = 1/ $\mu\text{S}/\text{cm}$

† FDA compliant materials with certification to meet EN10204 3.1 & USP <88> Class VI

DCC1000e System with ISM

Precise Detection of Corrosive Contaminants



ISM[®]

The METTLER TOLEDO Thornton DCC1000e System offers a new streamlined design for conductivity measurement of power cycle chemistry monitoring. By providing measurements in compliance with ASTM D4519 combined with digital sensor technology, this system provides assurance of water purity to maximize power production and minimize corrosion.

Features / Benefits:

- Precise detection of corrosive contaminants through digital sensor technology: Faster plant start-ups and simpler turbine warranty compliance
- Multi-parameter M800 transmitter with single-screen display of all measurements with touchscreen simplicity: Easy parameter display, monitoring and control in one transmitter
- Integrated turbine flow sensor: For precision control of system flow and system safety with auto shutoff
- Resin column monitoring of deionization capacity: Provides direct information of resin column health through our unique DI-Cap™ feature

Typical Applications

- Feed water and steam monitoring during plant startups to decide how quickly to bring the turbine online.
- Power steam quality monitoring to ensure turbine warranty conditions are met.
- Power condensate monitoring to help differentiate between air in-leakage and cooling water leaks.

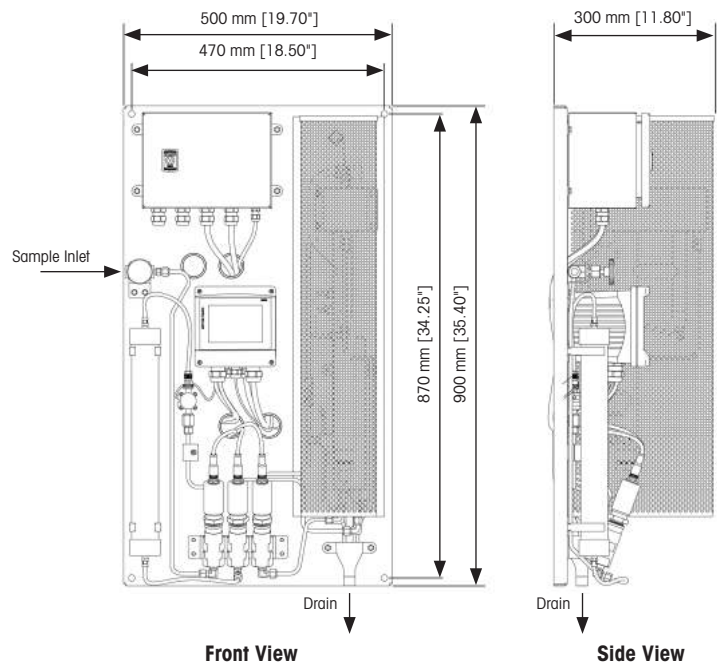

► www.mt.com/DCC1000e

System Specifications

Power supply	100 – 140 VAC and 200 – 240 VAC, 1600 W typical
AC frequency	50 to 60 Hz
Sample flow rate	150 – 350 mL/min
Sample temperature	20–60 °C (68–140 °F)*
Sample pressure	0.3–4 bar (5–58 psig)
Cation resin	600 cm ³
Ambient operating temperature	5–50 °C (41 – 122 °F)
Humidity	10–90% non-condensing
Dimensions (HxWxD)	900 × 500 × 300 mm (35.4 × 19.7 × 11.8")
Weight	29 kg (63.9 lb)
Rating / approvals	CE

* Option for external cooling for temperatures above 60 °C

Sensor: UniCond with ISM

Accuracy	± 1%
Repeatability	± 0.25%
Temperature sensor	Pt 1000 RTD, IEC 60751, Class A, with NIST-traceable calibration
Temperature accuracy	± 0.1 °C at 25 °C
Wetted materials	Titanium, PEEK
Response time	90% of value in < 3 s
Signal to transmitter	Digital (modified RS485)

Transmitter: Multi-parameter M800 with ISM

Current (analog) outputs	8 × 0/4 to 20 mA, 22 mA alarm, galvanically isolated from input and from earth/ground
Analog output accuracy	± 0.05 mA over 1 to 20 mA range
Analog output configuration	Linear, Bi-linear, Logarithmic, Auto ranging
Analog output load	500 Ω max.
Digital communication	USB, Type B connector
User interface	Color touchscreen 5.7" Resolution 320 × 240 px 256 colors
Update time (meas. update rate)	1 per second
Hold input	Selectable
Alarm control delay	Selectable, 0 to 999 s
Connection terminal	Spring cage terminals appropriate for AWG 16–24 / 0.2 mm ² wires
Relays	4-SPST mechanical rated at 250 VAC, 3 Amps (Relay 1 NC, Relay 2 to 4 NO); 4-SPST Type Reed 250 VAC or DC, 0.5 Amps (Relay 5 to 8)
Digital input	6 with switching limits 0.00 VDC to 1.00 VDC for low level 2.30 VDC to 30.00 VDC for high level
Main fuse	2.0 A slow blow type FC, not replaceable

Ordering Information

Description	Order Number
DCC1000e System, 100 – 140 VAC	30 421 478
DCC1000e System, 200 – 240 VAC	30 421 480
DCC1000e System with separate cooling input ports, 100 – 140 VAC	30 421 479
DCC1000e System with separate cooling input ports, 200 – 240 VAC	30 421 481

Analog Conductivity Sensors

A Comprehensive Series to Meet Industry Requirements



METTLER TOLEDO Thornton provides a full complement of analog conductivity/resistivity sensors with NPT or sanitary fittings. They include various lengths, cell constants and materials to match the application: titanium concentric electrodes for high purity water; monel electrodes for rinse waters containing HF; highly polished 316 L stainless steel (SS) electrodes for pharmaceutical waters; CPVC and PEEK sensors with four flush electrodes for solutions with higher conductivity and/or suspended material.

Specifications

Cell constant accuracy	$\pm 1\%$, except $\pm 5\%$ system accuracy for 4-electrode & 10 constant
Cell constant repeatability	$\pm 0.25\%$, except $\pm 2\%$ for 4-electrode & 10 constant
Temperature sensor	Pt 1000 RTD, IEC 60751, Class A
Temperature accuracy	$\pm 0.1\text{ }^{\circ}\text{C}$ ($\pm 0.2\text{ }^{\circ}\text{F}$) at $25\text{ }^{\circ}\text{C}$ ($77\text{ }^{\circ}\text{F}$), except $\pm 0.5\text{ }^{\circ}\text{C}$ ($\pm 0.9\text{ }^{\circ}\text{F}$) for 4-electrode sensors
Cable jacket material	NPT: PVC, $80\text{ }^{\circ}\text{C}$ ($176\text{ }^{\circ}\text{F}$) rating Sanitary: PTFE, $200\text{ }^{\circ}\text{C}$ ($392\text{ }^{\circ}\text{F}$) rating
Max. sensor distance	60 m (200 ft), except 15 m (50 ft) for 244-Series
Finish, sanitary 0.1 cm^{-1} sensors	$R_a < 0.2\text{ }\mu\text{m}$ / $R_a < 8\text{ }\mu\text{in}$, 316L SS is electropolished
Insulator material	PEEK (0.01 & 0.1 constant); Noryl (10 constant)

Features Overview

- Precise factory calibration and certification of each cell constant and RTD
- Optimized 4-wire measuring circuitry provides exceptional rangeability and accuracy, eliminating cable effects
- Quick and easy installation

Typical Applications

- Pharmaceutical water
- Power and steam generation
- Semiconductor water treatment
- Recycle and reclaim water
- Wastewater treatment

For detailed information about conductivity sensors for M300:

Please refer to pages 174 – 175 for ordering information and drawings



Sensor Selection Criteria

- Thornton offers a wide variety of conductivity/resistivity sensors to accommodate most applications. Use the following criteria to select the appropriate sensor for your installation:
- Conductivity or resistivity range
 - Transmitter
 - Mounting type: insertion, retractable or submersion
 - Pipe connection and size
 - Chemical compatibility, including cleaning and disinfection processes
 - Temperature requirements, including steam and/or hot chemical cleaning

Calibration of Conductivity Sensors



Thornton Auto-loop Factory Calibration System

Thornton conductivity sensors are industry standards for determining water purity and solution concentration. Thornton ISO 9001 factory calibration and certification are NIST and ASTM traceable using Thornton's unique ultrapure auto-loop calibration system. Certification includes test and accuracy, plus materials as noted in sensor specifications.

USP pharmaceutical water monitoring requirements are met with sanitary sensors which provide accurate conductivity and temperature measurement. 316L stainless steel Tri-Clamp mounting sensors have an electropolished finish with roughness average (R_a) $< 0.2 \mu\text{m}$, $< 8 \mu\text{in}$.

4-electrode sensors are ideal for monitoring high conductivity applications, clean-in-place (CIP) solutions and deionizer regenerant concentrations.



Did You Know

Thornton conductivity systems are routinely used by other instrument suppliers as the reference to provide traceability when calibrating their instrumentation.



Conductivity Standard Solutions

Provided for sensor verification and recalibration, conductivity standards are produced, analyzed and documented in the METTLER TOLEDO Thornton ISO 9001 certified facility with processes similar to those used to calibrate high accuracy Thornton conductivity sensors. They are provided with label and certificate with lot number, certified value, expiration date, plus ASTM and NIST traceability data. These standards are analyzed and used at equilibrium with the atmosphere.

Specifications

Standard	Accuracy	Shelf Life	Order Number
25 $\mu\text{S/cm}$, 500ml, HCl	$\pm 3\%$	6 months	58 078 001
100 $\mu\text{S/cm}$, 500ml, KCl	$\pm 1\%$	12 months	58 078 002
1,000 $\mu\text{S/cm}$, 500ml, KCl	$\pm 1\%$	12 months	58 078 003
10,000 $\mu\text{S/cm}$, 500ml, KCl	$\pm 1\%$	12 months	58 078 004
100,000 $\mu\text{S/cm}$, 500ml, KCl	$\pm 1\%$	12 months	58 078 005

Conductivity/Resistivity Sensors

Accurate and Reliable

Analog Conductivity Sensors

Drawings

NPT 0.01 and 0.1 Constant

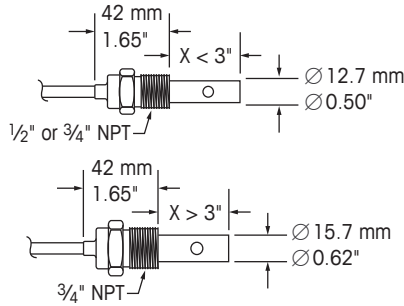

Sanitary, Standard

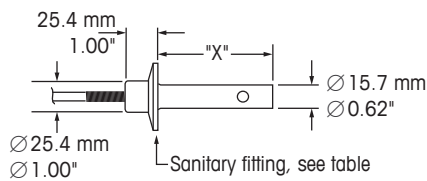

Sanitary, VP

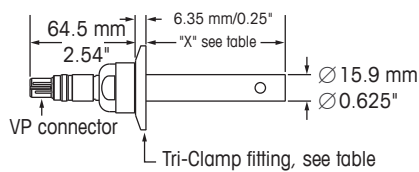

316SS Flow Housing (58 084 000)

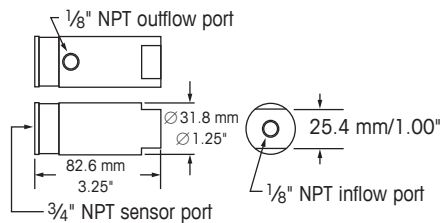

PVDF Flow Housing (58 084 001)

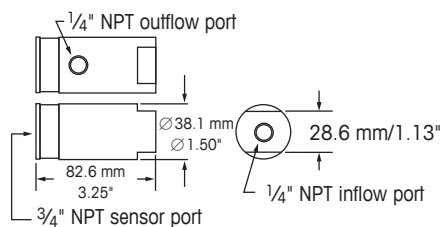

316SS Flow Housing (58 084 016)

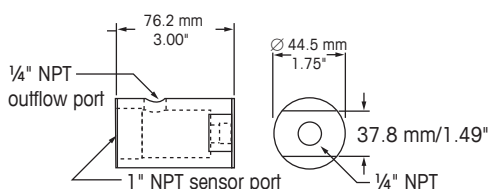

10 Constant (58 031 241)

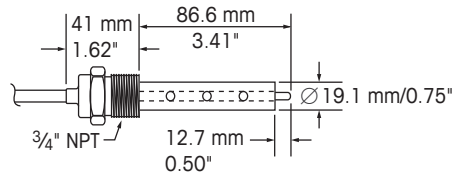

Submersion 0.1 Constant (58 031 207)

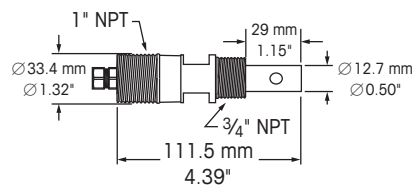

NPT 4-Electrode, CVPC

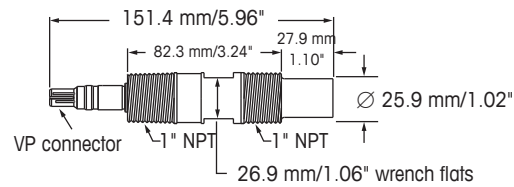

NPT 4-Electrode, PEEK

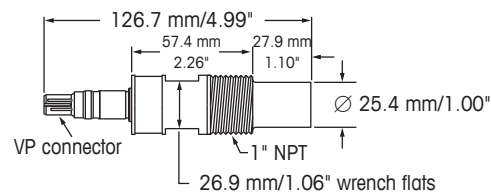

Sanitary 4-Electrode

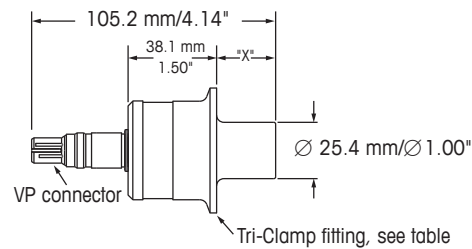

Boiler Water Conductivity Sensor

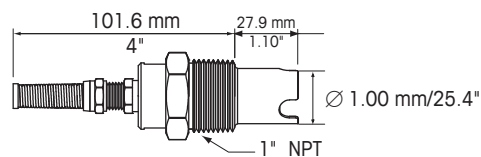

Ordering Information

Electrode Material	Maximum Pressure	Process Connection		Insertion Length "x"	Cable			Order Number
		- Fitting	- Material		Length	Connector		
2-Electrode Sensors								
- Measuring range 0.02–2,000 µS/cm (cell constant 0.1 cm⁻¹)^a								
Titanium	17 bar(g) at 93 °C (250 psig at 200 °F)	¾" NPTM	PTFE/SS	34 mm (1.35")	0.5 m (1.5 ft)	S		58 031 201
Titanium	17 bar(g) at 93 °C (250 psig at 200 °F)	¾" NPTM	PTFE/SS	132 mm (5.19")	0.5 m (1.5 ft)	S		58 031 202
Monel	17 bar(g) at 93 °C (250 psig at 200 °F)	¾" NPTM	PTFE/SS	34 mm (1.35")	0.5 m (1.5 ft)	S		58 031 203
Monel	17 bar(g) at 93 °C (250 psig at 200 °F)	¾" NPTM	PTFE/SS	132 mm (5.19")	0.5 m (1.5 ft)	S		58 031 204
316L SS	4 bar(g) at 131 °C (58 psig at 268 °F) 7 bar(g) at 95 °C (100 psig at 203 °F) 17 bar(g) at 25 °C (250 psig at 77 °F)	For Retractable housing ^b	SS	70 mm (2.75")	–	VP		52 001 998
Titanium	17 bar(g) at 93 °C (250 psig at 200 °F)	½" NPTM	Noryl	29 mm (1.14")	0.5 m (1.5 ft)	S		58 031 213
Titanium	17 bar(g) at 93 °C (250 psig at 200 °F)	¾" NPTM	Noryl	29 mm (1.14")	0.5 m (1.5 ft)	S		58 031 214
Titanium	17 bar(g) at 93 °C (250 psig at 200 °F)	¾" NPTM	PTFE/SS	34 mm (1.35")	3 m (10 ft)	S		58 031 215
Titanium	17 bar(g) at 93 °C (250 psig at 200 °F)	½" NPTM	PTFE/SS	29 mm (1.14")	0.5 m (1.5 ft)	S		58 031 216
Titanium	17 bar(g) at 93 °C (250 psig at 200 °F)	¾" NPTM	PTFE/SS	34 mm (1.35")	6.1 m (20 ft) ^c			58 031 217
Titanium	17 bar(g) at 93 °C (250 psig at 200 °F)	½" NPTM	PTFE/SS	29 mm (1.14")	3 m (10 ft) ^c			58 031 218
Titanium	17 bar(g) at 93 °C (250 psig at 200 °F)	¾" NPTM	PTFE/SS	34 mm (1.35")	9 m (30 ft) ^c			58 031 220
Titanium	10 bar(g) at 155 °C (150 psig at 311 °F) 31 bar(g) at 25 °C (450 psig at 77 °F)	1.5" Tri-Clamp	Titanium	86 mm (3.38")	0.5 m (1.5 ft)	S		58 031 221 ^d
316L SS	10 bar(g) at 155 °C (150 psig at 311 °F) 31 bar(g) at 25 °C (450 psig at 77 °F)	1.5" Tri-Clamp	316L SS	86 mm (3.38")	0.5 m (1.5 ft)	S		58 031 223 ^d
316L SS	10 bar(g) at 155 °C (150 psig at 311 °F) 31 bar(g) at 25 °C (450 psig at 77 °F)	2" Tri-Clamp	316L SS	105 mm (4.13")	0.5 m (1.5 ft)	S		58 031227 ^d
Titanium	17 bar(g) at 93 °C (250 psig at 200 °F)	¾" NPTM	PTFE/SS	34 mm (1.35")	0.5 m (1.5 ft)	VP		58 031 232
Titanium	17 bar(g) at 93 °C (250 psig at 200 °F)	¾" NPTM	PTFE/SS	132 mm (5.19")	0.5 m (1.5 ft)	VP		58 031 233
316L SS	10 bar(g) at 155 °C (150 psig at 311 °F) 31 bar(g) at 25 °C (450 psig at 77 °F)	1.5" Tri-Clamp	316L SS	55 mm (2.17")	–	VP		58 031 226 ^d
316L SS	10 bar(g) at 155 °C (150 psig at 311 °F) 31 bar(g) at 25 °C (450 psig at 77 °F)	1.5" Tri-Clamp	316L SS	85 mm (3.35")	–	VP		58 031 234 ^d
316L SS	10 bar(g) at 155 °C (150 psig at 311 °F) 31 bar(g) at 25 °C (450 psig at 77 °F)	2" Tri-Clamp	316L SS	104 mm (4.10")	–	VP		58 031 235 ^d
- Measuring range 0.002–200 µS/cm (cell constant 0.01 cm⁻¹)^a								
Titanium	17 bar(g) at 93 °C (250 psig at 200 °F)	¾" NPTM	PTFE/SS	60 mm (2.38")	0.5 m (1.5 ft)	S		58 031 230
- Measuring range 10–20,000 µS/cm (cell constant 0.4 cm⁻¹)^a								
316L SS	35 bar(g) at 25 °C (500 psig at 77 °F) 17 bar(g) at 200 °C (250 psig at 392 °F)	1" NPTM	316L SS	28 mm (1.10")	3 m (10 ft)	VP		58 031 264
- Measuring range 50–40,000 µS/cm (cell constant 10 cm⁻¹)^a								
Graphite	17 bar(g) at 93 °C (250 psig at 200 °F)	¾" NPTM	PTFE/SS	86 mm (3.38")	0.5 m (1.5 ft)	S		58 031 241
4-Electrode Sensors^e								
- Measuring range 10–650,000 µS/cm								
316L SS ^d	5 bar(g) at 150 °C (70 psig at 302 °F) 14 bar(g) at 50 °C (200 psig at 122 °F)	1.5" Tri-Clamp	PEEK	25 mm (1.00")	–	VP		58 031 242
316L SS ^d	5 bar(g) at 150 °C (70 psig at 302 °F) 14 bar(g) at 50 °C (200 psig at 122 °F)	2" Tri-Clamp	PEEK	25 mm (1.00")	–	VP		58 031 243
Hastelloy C ^d	5 bar(g) at 150 °C (70 psig at 302 °F) 14 bar(g) at 50 °C (200 psig at 122 °F)	1.5" Tri-Clamp	PEEK	25 mm (1.00")	–	VP		58 031 245
316L SS ^d	5 bar(g) at 150 °C (70 psig at 302 °F) 14 bar(g) at 50 °C (200 psig at 122 °F)	1.5" Tri-Clamp	PEEK	12 mm (0.50")	–	VP		58 031 248
Hastelloy C	7 bar(g) at 93 °C (100 psig at 200 °F) 14 bar(g) at 25 °C (200 psig at 77 °F)	1" NPTM	PEEK	28 mm (1.10")	–	VP		58 031 239
316L SS	3.5 bar(g) at 80 °C (50 psig at 176 °F) 7 bar(g) at 25 °C (100 psig at 77 °F)	1" NPTM	CPVC	28 mm (1.10")	–	VP		58 031 240
Hastelloy C	3.5 bar(g) at 80 °C (50 psig at 176 °F) 7 bar(g) at 25 °C (100 psig at 77 °F)	1" NPTM	CPVC	28 mm (1.10")	–	VP		58 031 244

^a MΩ × cm = 1 / (µS/cm)

^b See pages 184–185 for retractable housing (also used for pH and ORP)

^c Tinned leads – no patch cord required

^d Includes material certification to meet EN 10204 3.1 & USP<88> ClassVI

^e 4-electrode sensor, maximum patch cord length 15 m (50 ft)

S = Standard connector used with 58 080 25X patch cords only.

See page 233.

VP = VarioPin sealed connector used with 58 080 20X patch cords only

(58 080 101 3-ft adapter cable can connect an existing 58 080 25 X patch cord to a VP sensor). See page 233.

pH and ORP Systems Reliable in Pure Water Treatment Applications

With many decades of experience in designing pH/ORP electrodes METTLER TOLEDO offers a state-of-the-art solution for practically any type of process analytical application.

Functional definition

pH can be described as a measurement of the relative acidity of a solution. Oxidation reduction potential (ORP) as measured with an ORP electrode, provides an indication of the oxidative state of the solution. It is important to measure, and often to control the pH and/or ORP of a solution for several reasons:

- To produce products with consistent well defined properties
- To efficiently produce products at optimal cost
- To avoid health risks

- To protect the environment
- To prevent physical/chemical damage to materials
- To meet regulatory requirements
- To expand scientific knowledge

The accurate measurement of pH/ORP is critical in most industries. Each application has unique physical requirements of chemical, temperature, and pressure resistance and possibly hygienic design. Another factor is what is to be done with the measurement: monitoring only, data logging or process control.

pH electrode selection

It is important to understand the details of the application before selecting a pH electrode. The table on the next page gives an initial glance at the various electrodes available and typical applications. Selection of a pH electrode requires a thorough knowledge of the process. Once the requirements are known, comparison of the electrode specifications detailed in this catalog will identify the appropriate sensor.



InPro 3250 i/SG-120



pHure LE



4260 i/SG-120

**Thornton pH electrode selection guide
by industry and application**

	ORP * Pt 4805 – DPA	Pt 4805 (high pressure) – Dxx pH	4010	3250(i)	4260(i)	4501	pHure Sensor	pHure Sensor LE
Industrial processes								
Pharmaceutical Industry								
Makeup water	•	•		•				
Wastewater				•	•	•		
Power Industry								
Makeup water	•	•		•			•	
Cycle chemistry	•			•			•	•
Stator cooling				•			•	•
Scrubber					•	•		
Wastewater				•	•	•		
Semiconductor Industry								
Makeup water	•	•		•			•	
Recycle, reclaim, waste			•	•	•	•		
Water Treatment								
Air scrubbers		•			•	•		
Cooling water		•	•	•	•	•		
Neutralization	•	•	•	•	•	•		
Potable water			•	•				
Wastewater Treatment								
Flue gas neutralization		•		•	•	•		
Galvanic wastewater	•	•		•	•	•		
Industrial wastewater		•			•	•		
Precipitation of heavy metals		•		•	•	•		
Sludge dewatering		•			•	•		

* New pH/ORP sensors with ISM allow measurement of pH and ORP with the same sensor!

pH/ORP Sensors with ISM Convenient Maintenance and Calibration



4260i/SG-120 3250i/SG-120

ISM®

4260i/SG-225
For Retractable
Housing

METTLER TOLEDO Thornton offers pH and ORP sensors designed specifically for water treatment. The inclusion of ISM technology allows Plug and Measure capabilities, easier maintenance and convenient calibration. A variety of housings ensure a wide range of installation requirements can be met. The solution ground feature enables ORP measurement and ISM sensor diagnostics, and prevents measurement errors due to ground potentials.

Specifications

General

Measuring electrode	Glass pH, platinum ORP/solution ground
Reference electrode	Silver-silver chloride with double junction or equivalent
Temperature compensator	NTC included in all sensors
pH range	0 – 14 pH, except InPro 4010 which is 2 – 12 pH
Maximum flow	3 m/s (10 ft/s)
Max. cable lengths	80 m (262.4 ft)

For electrode ratings see table "Ordering Information" on the next page.

For housings see pages 184 – 185.

Features Overview

- Convenient electrical and process connections for easy maintenance and calibration
- Advanced METTLER TOLEDO sensor technology for high performance and long life
- Integral temperature sensing for accurate measurement and compensation
- On-line pH sensor diagnostics for assurance of process surveillance

Typical Applications

- Wastewater neutralization
- Pharmaceutical water treatment
- Power and steam generation cycle chemistry and scrubbers
- Semiconductor ultrapure water treatment

Ordering Information

ISM Electrodes	Rating	Sensor Type	Electrode Conn.	Housing Conn.	Length	Order Number
– For pH & ORP, General Purpose, High Pressure Applications ISM						
4260i-SG-120	See housing limits	Glass and Pt	K8S	Pg 13.5	120mm	52 005 381
– For pH & ORP, Retractable ISM						
4260i-SG-225	See housing limits	Glass and Pt	K8S	Pg 13.5	225mm	52 005 382
– For pH & ORP, General Purpose & Moderately Pure Water ISM						
3250i-SG-120	0 to 100 °C (32 to 212 °F)	Glass and Pt	K8S	Pg 13.5	120mm	52 005 373
– For pH, HF-Resistant Applications						
4262i-SG-120	See housing limits	Glass	K8S	Pg 13.5	120mm	30 018 467

Analog Electrodes	Rating	Sensor Type	Electrode Conn.	Housing Conn.	Length	Order Number
– For pH, General Purpose, Applications						
4010-120-Pt1000	0 to 60 °C (32 to 140 °F) 2 bar(g)/60 °C (30 psig/140 °F) 5 bar(g)/45 °C (75 psig/113 °F)	Polysulfone and glass	VP	Pg 13.5	120mm	52 000 512
– For pH, General Purpose, High Pressure Applications						
4260-120-Pt1000	See housing limits	Glass	VP	Pg 13.5	120mm	52 002 987
– For pH & ORP, General Purpose & Moderately Pure Water Applications*						
3250SG-120-Pt1000	0 to 100 °C (32 to 212 °F) 4 bar(g) (60 psig)	Glass	VP	Pg 13.5	120mm	52 002 559
– For pH, HF-Resistant Applications						
4262-120-Pt1000-VP	See housing limits	Glass	VP	Pg 13.5	120mm	52 003 550
– For pH, Retractable Applications						
4260-225-Pt1000	See housing limits	Glass	VP	Pg 13.5 retractable	225mm	52 002 989

Accessories	Order Number
iSense full version	30 130 614
iSense lite version	Available for free
iSense mobile version	Available for free
iLink cable for iSense	52 300 383

* For use with moderately pure waters (conductivity 5 to 50 µS/cm) use 53 300 021 housing in ¾" NPT(M) earth-grounded metal pipe tee with flow < 100 ml/min and discharge to open drain. For higher purity and/or higher accuracy in pure water see pHure Sensor, page 180–183.

* All new installations require an electrode, housing and cable.

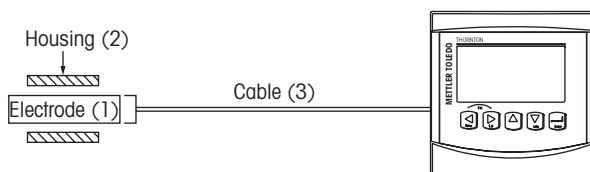

A complete pH or ORP installation requires an electrode (1), a housing (2) and a VP or AS9 cable (3). For suitable housings consult the table on page 172. For suitable cables see table pages 136–137 for analog or page 215 for ISM installations. Each installation requires a transmitter.

pHure Sensor with ISM

Reliable pH Measurement in Pure Waters



ISM®

The METTLER TOLEDO Thornton pHure Sensor® uses a special internally-pressurized gel electrolyte reference electrode to produce results similar to a flowing junction but with much more convenient installation and maintenance. The electrode also includes a low resistance pH glass membrane, an integral, fast-responding RTD, and AK9 connection. All components of the pHure Sensor have been optimized for performance and value and conform to ASTM Standard D5128. The inclusion of ISM technology allows Plug and Measure capabilities, easier maintenance and convenient calibration. Various lengths of cable can be selected to provide flexibility in locating the sensor.

Specifications

Wetted materials	pH Glass
Process connections	¼" NPT(F) in/out
Flow housing volume	5 ml with electrode in place
Maximum pressure	Atmospheric pressure for optimum stability; operational 0 to 2.5 bar(g) (0 to 35 psig); can safely withstand 7 bar(g) (100 psig)
Sample temperature	0 to 80 °C (32 to 176 °F); short term to 100 °C (212 °F)
Sample pH	1 – 11 pH
Sample flowrate	50 to 150 ml/min
Sample conductivity	> 1.5 µS/cm for highest accuracy
Connection	AK9 or VP cable from sensor to instrument

Features Overview

- Pressurized gel electrolyte
- Accurate, fast responding temperature compensator
- Low resistance glass membrane
- Solution ground connection
- Low volume 316 stainless steel flow housing

Typical Applications

- Reverse osmosis – pH adjustment of clean recycle water or between membranes in two pass systems to optimize rejection rates
- Power plant cycle chemistry
- Monitoring and controlling pH levels to comply with guidelines and minimize corrosion and scaling

Ordering Information

pHure Sensor		Order Number
pHure Sensor ISM combination electrode with temperature compensator		52 003 821
pHure Sensor combination electrode with RTD		52 002 447
* All new installations require a sensor, housing and cable.		
Housing		Order Number
Flow housing		58 084 010

Cables (pHure Sensor ISM combination electrode with temperature compensator)	
Cable length	AK9
1m (3.3 ft)	59 902 167
3m (9.8 ft)	59 902 193
5m (16.4 ft)	59 902 213
10m (32.8 ft)	59 902 230
20m (65.6 ft)	52 300 204
30m (98.4 ft)	52 300 393
50m (164.0 ft)	52 300 394
80m (262.4 ft)	52 300 395

Cables (pHure Sensor combination electrode with RTD)	
Cable length	VP
1m (3.3 ft)	52 300 107
3m (9.8ft)	52 300 108
5m (16.4 ft)	52 300 109
10m (32.8 ft)	52 300 110

Accessories		Order Number
iSense full version		30 130 614
iSense lite version		Available for free
iSense mobile version		Available for free
iLink cable for iSense		52 300 383

* For pH and ORP buffers, refer to page 185.

pHure Sensor dimensions

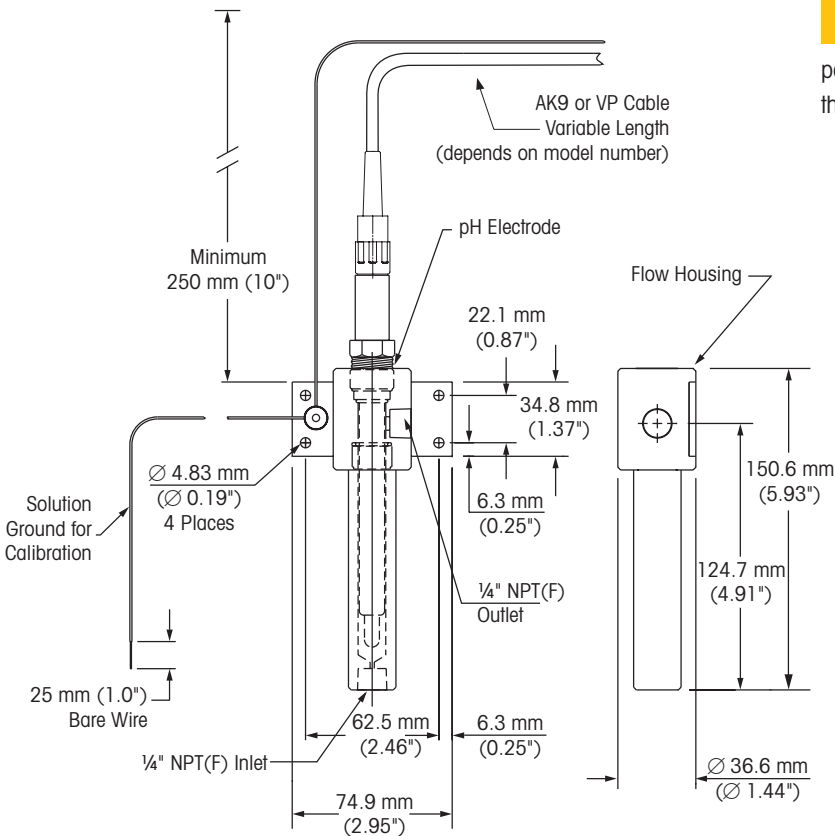

Did You Know

The small volume and high sample velocity of the pHure Sensor ensures fast response by preventing power plant corrosion products from accumulating around the electrode membrane.

pHure Sensor LE with ISM

Reliable pH Measurement in Pure Waters



ISM®

The METTLER TOLEDO Thornton pHure Sensor LE uses a free-flowing junction to provide the most accurate pH measurement available in low conductivity water. The electrode includes a special pH glass membrane, an integral, fast-responding temperature sensor, and VP or AK9 connection. All components of the pHure Sensor LE have been optimized for performance and value and conform to ASTM Standard D5128. The inclusion of ISM technology allows Plug and Measure capabilities, easier maintenance and convenient calibration. Various lengths of cable can be selected to provide flexibility in locating the sensor.

Specifications

Wetted materials	pH Glass, platinum solution ground/ORP
Process connections	1/4" NPT(F) in/out
Flow housing volume	5 ml with electrode in place
Maximum pressure	Atmospheric pressure for measurement; can safely withstand 7 bar(g) (100 psig)
Sample temperature	0 to 100 °C (32 to 212 °F)
Sample pH	1 – 12 pH
Sample flowrate	50 to 150 ml/min
Sample conductivity	> 0.3 µS/cm for highest accuracy
Connection	AK9 or VP cable from sensor to instrument
Reference electrode	3M KCl

Features Overview

- Free-flowing junction / diaphragm
- Simultaneous pH & ORP measurements
- Accurate, fast responding temperature compensator
- Low resistance glass membrane
- Low volume 316 stainless steel flow housing
- Easily refillable electrolyte chamber
- Specially designed Flow Housing with protective cover

Typical Applications

- Power plant cycle chemistry where pH measurement in low conductivity water is critical
- Reverse osmosis – pH adjustment of clean recycle water or between membranes in two pass systems to optimize rejection rates
- Monitoring and controlling pH levels to comply with guidelines and minimize corrosion and scaling

► www.mt.com/Thornton-pH

Ordering Information

pHure Sensor LE		Order Number
pHure Sensor LE ISM electrode		30 039 086
pHure Sensor LE analog electrode		30 039 085
* All new installations require a sensor, housings and cable.		
* For pH and ORP buffers, refer to page 185.		
Consumables		Order Number
Replacement electrolyte 3M KCl 250 ml		51 340 049
Replacement syringe for electrolyte refill		58 079 520
Housing		Order Number
SS flow housing with protective cover		58 084 017

Cables (pHure Sensor LE ISM combination electrode with temperature compensator)	
Cable length	AK9
1m (3.3 ft)	59 902 167
3m (9.8 ft)	59 902 193
5m (16.4 ft)	59 902 213
10m (32.8 ft)	59 902 230
20m (65.6 ft)	52 300 204
30m (98.4 ft)	52 300 393
50m (164.0 ft)	52 300 394
80m (262.4 ft)	52 300 395

Cables (pHure Sensor LE combination electrode with RTD)	
Cable length	VP
1m (3.3 ft)	52 300 107
3m (9.8 ft)	52 300 108
5m (16.4 ft)	52 300 109
10m (32.8 ft)	52 300 110

pHure Sensor LE dimensions

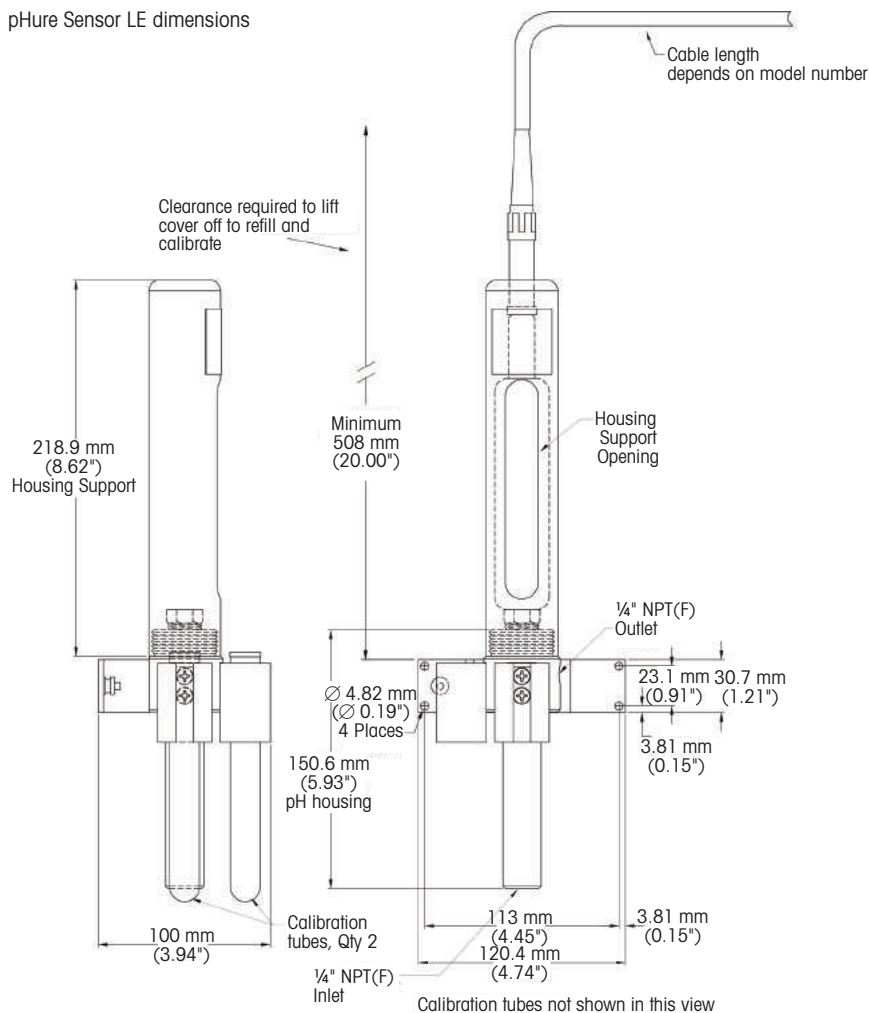

pH/ORP Housings

Flexibility in Meeting Process Requirements



53 300 021



58 084 014

METTLER TOLEDO Thornton housings provide a fixed NPT or solvent weld process connection. For easy access to the electrode for cleaning, calibration or replacement, they have internal O-ring seals with hand-tightened mounting nut. The compact METTLER TOLEDO electrode design includes measuring, reference and fast-responding temperature compensator functions so only a single process connection is ever needed.

Housings should be mounted to orient the tip of the electrode at least 15° below horizontal to ensure reliable contact of internal electrolyte with the measuring membrane. They should not be mounted horizontally or upside-down.

Specifications

pH Housings	Order Number		
	53 300 021	52 401 520	58 084 014
Wetted parts	CPVC	PVDF	PVC
Sensor fitting	¾" NPT(M) insertion or submersion ^a	¾" NPT(M) insertion or submersion ^a	1" weld tee
Pressure rating	7 bar(g) at 20 °C (100 psig at 68 °F) 2 bar(g) at 80 °C (30 psig at 176 °F)	6 bar(g) at 20 °C (87 psig at 68 °F) 1 bar(g) at 100 °C (15 psig at 212 °F)	3.5 bar(g) at 60 °C (50 psig at 140 °F)

Suitable pH sensors (by Order Number)^b:

- 52 005 381	•	•	•
- 52 005 373	•	•	•
- 52 000 512	•	•	•
- 52 002 987	•	•	•
- 52 002 559	•	•	•
- 30 018 467	•	•	•
- 52 003 550	•	•	•

pH Housings	Order Number
	58 084 002
Wetted parts	CPVC
Sensor fitting	Retractable 1½" NPT(M)
Pressure rating	5 bar(g) at 80 °C (75 psig at 176 °F)

Suitable pH sensors (by Order Number)^b:

- 52 005 382	•
- 52 002 989	•

^a For insertion in plastic pipe, use ¾ × 1" reducing bushing and 1" pipe tee.

For submersion with plastic pipe, use ¾ × 1" reducing coupling and 1" pipe.

^b For information about the corresponding pH sensors consult page 177.

Drawings of pH housings

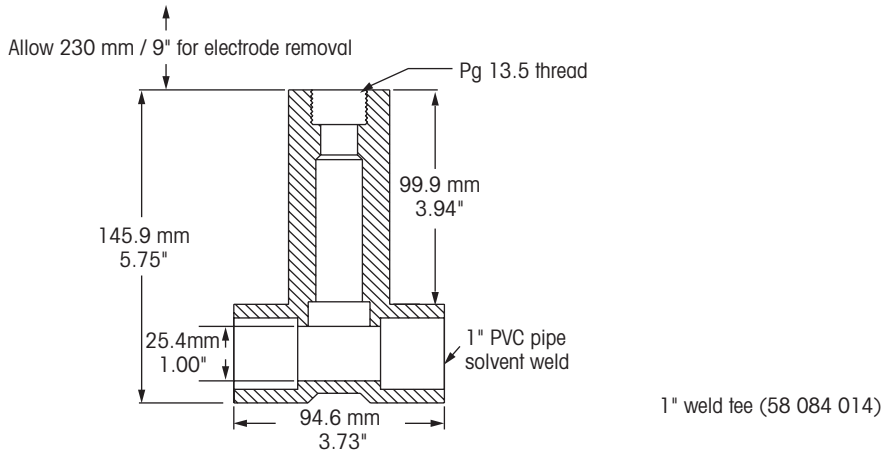
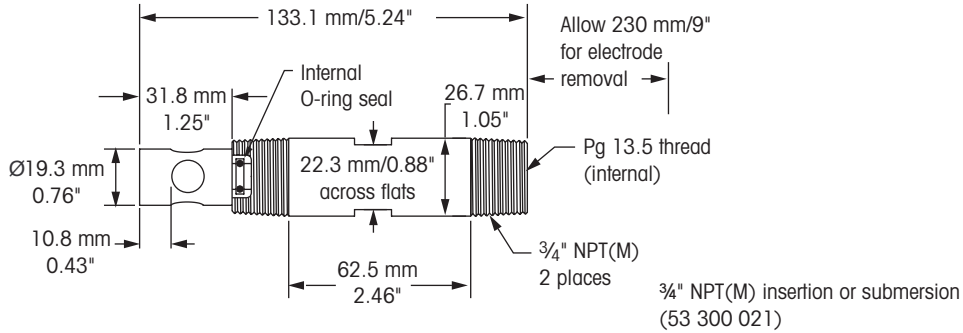

pH and ORP (Redox) Standard Buffer Solutions



Ordering Information

pH and Redox Buffers	Volume	Order Number
pH Buffers		
pH 4.01 buffer	250 ml	51 340 057
pH 7.00 buffer	250 ml	51 340 059
pH 9.21 buffer	250 ml	51 300 193
pH 10.00 buffer	250 ml	51 340 056
Redox Buffers		
Redox buffer 220 mV	6 × 250 ml	51 340 081

Introduction

High Process Efficiency Under Any Condition

Oxygen Measurement Systems

High Reliability and Wide Application Coverage

METTLER TOLEDO provides sensors to measure dissolved oxygen (DO) in demanding low ppb-level applications.

Measurement of dissolved oxygen

Proper oxygen levels are important in many processes involving the use of pure and ultrapure water. Control of dissolved oxygen will minimize corrosion, reduce costs or provide maximum semiconductor product yield.

The optical dissolved oxygen sensor

with its durable OptoCap sensing element ensures fast response time, highly accurate measurement, very low maintenance, and no dissolved hydrogen interference.

Electrochemical oxygen sensors

The Thornton high-performance sensors have been designed for in-line measurements of dissolved oxygen in the low ppb-range in power plant cycle chemistry and in ultrapure water applications of the semiconductor industry.

Professional service and validation

Sensor service includes rebuilding, cleaning, testing, and recertification of your Thornton sensor, done quickly and efficiently to minimize downtime.



Pure Water Optical DO Sensor



High Performance DO Sensor

Ozone Measurement Systems

Provide Accurate Response and Excellent Sensitivity

METTLER TOLEDO Thornton's dissolved ozone measurement systems show rapid and accurate response to ozone concentrations. The excellent sensitivity gives positive detection of zero ozone after destruction by UV light.

Measuring principles

Ozone passes through a gas-permeable reinforced membrane of exceptional durability producing an electrochemical reaction and current flow in direct proportion. Behind the membrane is the platinum cathode where ozone reacts to produce the measurement signal. The electrochemical reaction is completed at the silver anode. Full temperature compensation accounts for effects of both membrane permeability and solubility of ozone in water.

Important features

- Rapid, accurate response
- Positive zero detection
- Low maintenance with drop-in modular membrane

Ozone sanitization of pharmaceutical water systems

Complete sanitization is achieved by controlling ozonation downstream of the storage tank. A second ozone measurement guarantees the removal of all ozone downstream of UV destruction.

Ozone sanitization of semiconductor ultrapure water

Ozone sanitization can be controlled by monitoring the ozone concentration downstream of the ozonator and UPW storage tank. To be sure all ozone has been decomposed after UV lights, a second ozone measurement can confirm a zero level.

Ozone sanitization of bottled water

Continuous measurement and control to proper ozone levels of bottled water is a required quality practice that promotes consistent good taste and long shelf life.

Ozone sanitization of beverage systems

Ozonated water is used in place of chemicals for CIP operations when changing between flavors. Ozone provides cleaning and disinfection without risk of objectionable residuals or byproducts.



pureO₃ Dissolved Ozone Sensor

Pure Water Optical DO Sensor

Fast Response, Reduced Maintenance



ISM[®]

METTLER TOLEDO Thornton's Optical DO Sensor provides high accuracy, fast response and increased stability in demanding low ppb-level applications. The outstanding measurement performance with low detection limit, minimum drift and shorter response time improves oxygen monitoring. The proprietary OptoCap design allows highly accurate measurement of dissolved oxygen without susceptibility to hydrogen interference in power generation. The easy maintenance without liquid handling and polarization increases the availability of the measuring system. Easy maintenance, without liquid handling and sensor polarization increases the convenience of the measuring system. Predictive maintenance with ISM permits easy maintenance planning, reducing downtime.

Specifications

Operating range	0 – 5000 ppb
System accuracy	± 2 % of reading or 2 ppb, whichever is greater
Response time at 25 °C (77°F) (Air_N ₂)	98 % of final value in < 20 s
Sampling rate	Adjustable between 1 and 60 seconds
Sample flow rate	50 – 800 ml/min
Temperature compensation	Automatic
Measuring temperature range	0 – 50 °C (50 – 122 °F) for DO measure
Environmental temperature range	0 to 121 °C (32 to 250 °F)
Operating pressure	0.2 to 12 bar (2.9 to 174 psi absolute)
Design pressure	Maximum 12 bar (174 psi absolute)
Sample connections	¼" NPT(F)
Wetted materials	Stainless steel, silicone, EPDM O-ring
Cable length	2 – 50 m (6.6 – 164.0 ft)
Components needed	Optical DO probe, housing and cable

Construction

Measuring principle	Fluorescence quenching
Cable connection	5-pin
Connector design	Straight
Sensor body	316L stainless steel
Membrane material	Silicone
O-ring material	EPDM (FDA-positive listed)
Sensor diameter	12 mm

Features Overview

- High accuracy
- Fast response
- Enhanced stability and reliability
- Reduced maintenance and downtime
- No dissolved hydrogen interference
- No flow sensitivity

Typical Applications

- Power plant cycle chemistry monitoring
- Generator stator cooling
- Semiconductor ultrapure water
- Pure water treatment systems

Ordering Information

Optical DO Sensor	Order Number
Pure Water ISM Optical DO Probe	30 041 040
* All new installations require a sensor, housing and cable.	
Required Accessories	
Pure Water 316 Stainless Steel Housing	58 084 018
Sensor Cables	
2 m (6.6 ft)	52 300 379
5 m (16.4 ft)	52 300 380
10 m (32.8 ft)	52 300 381
15 m (49.2 ft)	52 206 422
25 m (82.0 ft)	52 206 529
50 m (164.0 ft)	52 206 530
Spare Parts	
OptoCap Replacement Kit	52 206 403
Accessories	
iSense full version	30 130 614
iSense lite version	Available for free
iSense mobile version	Available for free
iLink cable for iSense	52 300 399

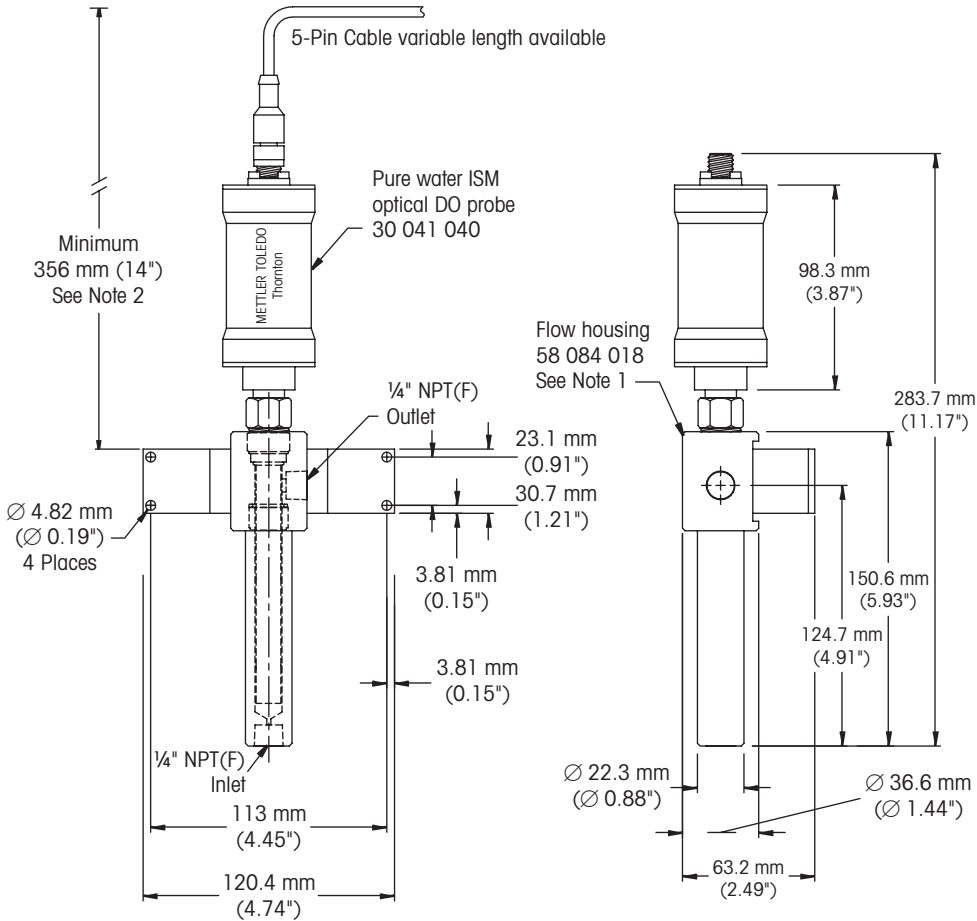

Notes:

1. Electrode/Flow housing assembly must be in upright position as shown.
2. Allow at least 356 mm (14") clearance to remove sensor.

High Performance Dissolved Oxygen Sensors with ISM

Fast, Accurate Response



ISM®

METTLER TOLEDO Thornton's high performance ppb-level dissolved oxygen measurement capability excels in demanding low ppb-level applications. It provides a precise zero and a highly accurate response over the entire range of measurement. This allows it to perform well at any level as well as providing very fast response to changes from one level to another. The inclusion of ISM technology allows Plug and Measure capabilities, easier maintenance and convenient calibration.

Specifications

Sample flow rate	50 to 1,000 ml/min
Sample temperature	0 to 60 °C (32 to 140 °F) for temperature compensation; can tolerate 100 °C (212 °F)
Sample pressure	0 to 5 bar(g) (0 to 72 psig)
Sample connections	1/4" NPT(M)
Wetted materials	Polyacetal flow housing, polyphenylene sulfide probe body, PTFE membrane reinforced with stainless steel and silicone rubber, Viton® and silicone rubber O-rings
Cable length	Probe to instrument: 1 to 80 m (3.3 to 262.4 ft)
Weight	1 kg (2 lb) with flow housing
Response time	98 % of final value in 90 s
Operating range	0–10,000 ppb (µg/L)
System accuracy	± 1 % of reading or 1 ppb, whichever is greater; ± 0.5 °C

Features Overview

- High accuracy
- Simple maintenance with drop-in modular membrane
- Excellent long-term stability
- Temperature compensation for membrane permeability and oxygen solubility effects

Typical Applications

- Power plant cycle chemistry monitoring
- Semiconductor ultrapure water
- Pure water treatment systems

Ordering Information

High Performance Dissolved Oxygen Sensor	Order Number
ISM High Performance DO probe	52 201 209
Analog High Performance DO probe	52 201 067
Spare parts and Accessories for All High Performance Sensors	
Maintenance kit (electrolyte and 4 membranes)	52 200 024
Analog Polarization module (for portable use with VP cable)	52 200 893
DO electrolyte pack (3 × 25 ml)	30 298 424
Single membrane body	52 200 071
Flow housing	58 084 009

* All new installations require a sensor, housing, cable and electrolyte.

Cables (High Performance Dissolved Oxygen probe ISM)	
Cable length	AK9
1m (3.3 ft)	59 902 167
3m (9.8 ft)	59 902 193
5m (16.4 ft)	59 902 213
10m (32.8 ft)	59 902 230
20m (65.6 ft)	52 300 204
30m (98.4 ft)	52 300 393
50m (164.0 ft)	52 300 394
80m (262.4 ft)	52 300 395

Cables (High Performance Dissolved Oxygen probe analog)	
Cable length	VP
1m (3.3 ft)	52 300 107
3m (9.8 ft)	52 300 108
5m (16.4 ft)	52 300 109
10m (32.8 ft)	52 300 110

Accessories	
iSense full version	30 130 614
iSense lite version	Available for free
iSense mobile version	Available for free
iLink cable for iSense	52 300 383

Dimensions of the ISM High Performance Dissolved Oxygen Sensor

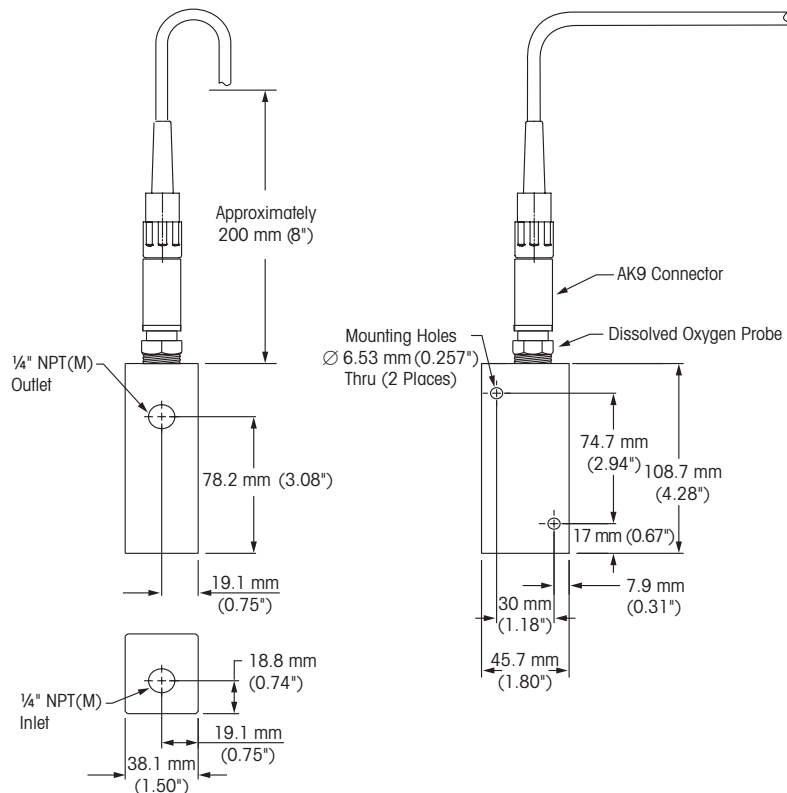

Did You Know

The fast response of high performance DO sensors allows real-time tracking of start-up deaeration.

pureO₃ Dissolved Ozone Sensor with ISM For Reliable Process Control



ISM®

The pureO₃[™] dissolved ozone sensor uses proven technology along with ISM for rapid and accurate response to a wide range of ozone concentrations. pureO₃ provides reliable ozone measurement in conjunction with many transmitters including various M800, M400, M300 and M200 ISM models. Intelligent sensor data is stored in memory, providing Plug and Measure simplicity with enhanced diagnostics capabilities. Robust sensor construction is coupled with a membrane cartridge which allows exceptionally fast and easy replacement of electrolyte and membrane when necessary.

Specifications

Sample flow rate	200 to 500 ml/min with housing; 0.15 to 1 m/s (0.5 to 3 ft/s) without housing
Sample temperature	5 to 50 °C (41 to 122 °F) for compensation; probe can withstand 100 °C (212 °F)
Sample pressure	Normal operation, atmospheric; can withstand 0.8 to 3 bar absolute (0 to 45 psig)
Sample connections	1/4" NPT(F)
Wetted materials	Polycarbonate or 316 stainless steel flow housing, 316L/1.4404 stainless steel probe, silicone rubber membrane, FKM O-rings
Cable lengths	1 to 80 m (3.3 to 262.4 ft)
Weight	0.5 lb (227 g)
Response time	90% response in 30 s
Operating range	0–5,000 ppb (mg/L); 0–5.0 ppm (mg/L) short term; 0–500 ppb (mg/L); 0–0.5 ppm (mg/L) continuous
System accuracy	± 1% of reading or 0.4 ppb, whichever is greater

Features Overview

- Reinforced silicone membrane for exceptional durability
- Full temperature compensation accounts for effects of both membrane permeability and solubility of ozone in water
- Membrane cartridge provides easy replacement of electrolyte and membrane
- 21CFR Part 11 Data Integrity option when paired with an M800 Transmitter and RecordLOC software (see page 203)

Applications

- **Pharmaceutical water systems**
Monitors sanitization levels and ensures removal of all ozone to satisfy the “no added substance” requirement, plus data integrity.
- **Semiconductor ultrapure water systems**
Monitors ozone concentration downstream of the ozonator and UPW storage tank

– Bottled water systems

Continuous ozone measurement is a key quality practice to provide good, consistent taste and long product shelf life

– Beverage systems

Ozone replaces caustic chemicals for clean-in-place operations, providing disinfection without objectionable byproducts

▶ www.mt.com/Thornton-Ozone

Ordering Information

Ozone Sensor	Order Number
pureO ₃ Dissolved Ozone sensor	30 139 305
Required Accessories	
Polycarbonate Housing	58 084 012
Stainless Steel Housing	58 084 020
Spare Parts	
pureO ₃ membrane kit including electrolyte, 4 membranes and O-rings	30 235 170
Interior sensor body for pureO ₃	30 236 790
pureO ₃ electrolyte, 25 ml	30 135 837
ISM Sensor Cables	
1.0m (3.3 ft)	59 902 167
3.0m (9.8 ft)	59 902 193
5.0m (16.4 ft)	59 902 213
10.0m (32.8 ft)	59 902 230
20m (65.6 ft)	52 300 204
30m (98.4 ft)	52 300 393
50m (164.0 ft)	52 300 394
80m (262.4 ft)	52 300 395

* All new installations require a sensor, housing and cable.

Dimensions

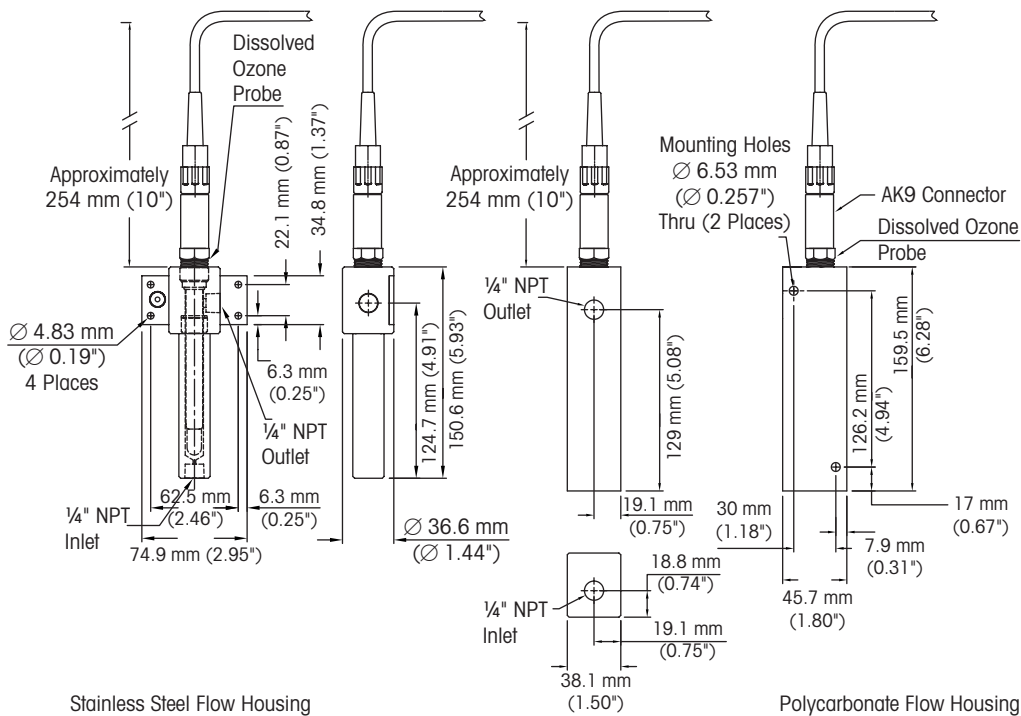

Notes:

- Sensor/flow housing assembly must be in upright position as shown.
- Allow approximately 254 mm (10") clearance to remove sensor.

Paddlewheel Flow Sensors

Reliable and Economical

In-line Paddlewheel



SE30 Paddlewheel Insert



PVC True Union Body*



Female NPT
Threaded SS*



Stainless Steel
Tri-Clamp*

*Paddlewheel SE30 and flow fittings sold separately

In-line paddlewheel flow sensors provide continuous flow measurement at a low cost for a variety of solids-free liquid applications. The open cell rotor is made of PVDF and the shaft and bearing of ceramic material offering superior life and operating performance. The modular quarter-turn electronics assembly makes service and maintenance fast and easy and allows the removal of the electronics without removing the entire sensor body.

Specifications

In-line Paddlewheel

Mounting fitting	Ordered separately (see next page for options)
Straight pipe requirements	Pipe diameters: 10 X upstream, 3 X downstream
Wetted materials	PVC versions: PVC, PVDF, Ceramic, Viton® Tri-Clamp SST versions: SS, PVDF, Ceramic, EPDM NPT threaded SST versions: SS, PVDF, Ceramic
Flow ranges	0.3–10 m/s (1–33 ft)
Pressure	PVC versions: 10bar at 50°C (140 psig at 122°F) SST versions: 16bar at 100°C (230 psig at 212°F)
Accuracy	± 0.5% of full scale, + 2.5% of Reading with standard mean K-factor in reference conditions: water at 20°C (68°F)
Linearity	≤± 0.5% of full scale, at 10 m / s (32.8 fps)
Repeatability	0.4% of Reading
Power supply	5-15 V DC ("Low Voltage" version)
Current consumption	≤ 0.8 mA
Output frequency	Transistor NPN, open collector, max. 10 mA, frequency: 0...300 Hz; duty cycle 1/2
Environment temperature	0°C to 60°C (32°F to 140°F)
Relative humidity	≤ 80%, non-condensated
Fluid temperature	PVC version: 0°C to 50°C (32°F to 140°F) SST versions: -15°C to 100°C (5°F to 212°F)
Enclosure rating	NEMA 4X (IP 65)
Electronics enclosure material	PC (Polycarbonate)
EMC	EN 61000-6-2, 6100-6-3
Vibration	EN 60068-2-6
Shock	EN 60068-2-27
Wiring	Use 3-conductor, 20 gauge, shielded cable such as Belden 9364, or equivalent. Maximum recommended cable length is 50m (160 ft)
Linearity	1% FS
Repeatability	± 0.5% of full scale, except ± 0.25% of full scale for 1/4" NPT models
Certification	CE rated

Ordering Information

Pulse Paddlewheel Flow Sensor

Order Number

Type SE30 Insert Sensor

58 034 636

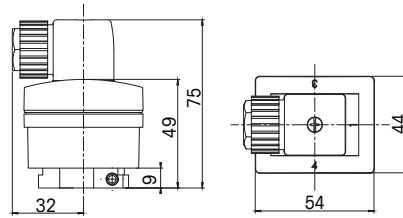

Ordering Information

True-Union Nut with Solvent Ends (PVC)

Body Size	ØD mm/inch	ØD1 mm/inch	A2 mm/inch	A1 mm/inch	A mm/inch	H mm/inch	Order Number
1/2"	21.3/0.840	43/1.69	90/3.54	96/3.78	130/5.12	100.5/3.96	58 034 637
3/4"	26.7/1.050	53/2.09	100/3.94	106/4.17	145.6/5.73	98.0/3.86	58 034 638
1"	33.4/1.315	60/2.36	110/4.33	116/4.57	161.4/6.35	98.0/3.86	58 034 639
1 1/4"	42.2/1.660	74/2.91	110/4.33	116/4.57	170.0/6.69	102.0/4.02	58 034 640
1 1/2"	48.3/1.900	83/2.09	120/4.72	127/5.00	190.2/7.49	105.5/4.15	58 034 641
2"	60.3/2.375	103/4.06	130/5.12	136/5.35	213.6/8.41	112.0/4.41	58 034 642

SST, Stainless Steel Body with NPT Threaded Connections

Body Size	ØD Female NPT	A mm/inch	H mm/inch	Order Number
1/2"	1/2"	17.0/0.67	100.5/3.96	58 034 643
3/4"	3/4"	18.3/0.72	98.0/3.86	58 034 644
1"	1"	18.0/0.71	98.0/3.86	58 034 645
1 1/2"	1 1/2"	21.0/0.83	105.5/4.15	58 034 647
2"	2"	24.0/0.94	114.0/4.41	58 034 648

SST, ASME-BPE Tri-Clamp Body Style—See Table D

Body Size	ØD mm/inch	ØD1 mm/inch	ØD2 mm/inch	A mm/inch	H mm/inch	Order Number
3/4"	25/0.98	19.6/0.77	15.75/0.62	119/4.69	98.0/3.86	58 034 649
1"	50.5/1.98	4.35/1.71	22.1/0.87	129/5.08	98.0/3.86	58 034 650
1 1/2"	50.5/1.98	43.5/1.71	34.8/1.37	161/6.34	105.5/4.15	58 034 651
2"	64.0/2.52	56.5/2.22	47.5/1.87	192/7.56	112.0/4.41	58 034 652
2 1/2"	77.5/3.05	70.5/2.78	70.5/2.78	216/8.50	112.0/4.41	58 034 653

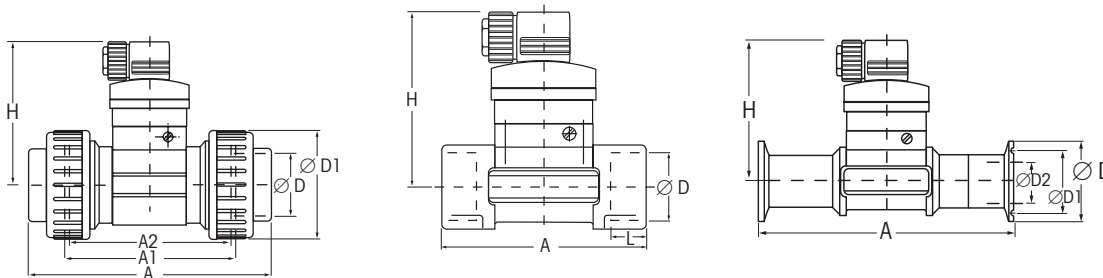

Flow Transmitter Options

Model	Mounting	Flow Channels	Order Number
M200, Flow 1-channel	1/4-DIN Panel	1	30 280 748
M200, Flow 4-channel	1/4-DIN Panel	4	30 280 749
M800*, Water 2-channel	1/2-DIN	2	58 000 802
M800*, DP Water 2-channel	1/2-DIN	2	58 000 806
M800*, Water 4-channel	1/2-DIN	2	58 000 804

*The M800 Pulse Flow Adapter (part number 58 080 116) allows an M800 ISM channel to be used with a pulse flow sensor to expand the number of flow sensors per M800 transmitter. The pulse output of the flow sensor is converted to a digital signal at the adapter and transmitted to the M800's ISM channel. By using the adapters, you can now connect up to four pulse flow sensors to a 2-channel M800 (2 ISM channels + 2 pulse channels) or six flow sensors to a 4-channel M800 (4 ISM channels + 2 pulse channels).

See p. 224 – 235 for full flow capabilities.

Forward-Swept Impeller Sensors with Fittings

Economical non-magnetic measurement

In-line Paddlewheel



Non-magnetic sensors feature a closed, six-bladed impeller design, using a non-magnetic sensing technology. The forward-swept impeller shape provides higher, more constant torque than four-bladed impeller designs, and is less prone to fouling by water-borne debris. The forward-curved shape, coupled with the absence of magnetic drag, provides improved operation and repeatability, even at lower flow rates. Models feature a modified PVC tee with solvent weld socket end connections, and a removable, PPS sensor insert in sizes 2, 3, and 4 inches.

Specifications

In-line Paddlewheel

Mounting fitting	PVC Socket weld fitting in sizes 2, 3, or 4 inches included with insertion sensor
Straight pipe requirements	Pipe diameters: 10 X upstream, 5 X downstream
Electrical connections	Models have 6.1 m (20 ft) cables and may be extended up to 610 m (2,000 ft) using 2-conductor 20 gauge, shielded cable: type PTLC 105°C cable.
Wetted materials	PVC Tee, PPS, Nylon, tungsten carbide, EPDM
Flow ranges	0.15–9 m/s (1–30 ft)
Pressure	100 psi at 25°C From 25° to 60°C (77° to 140°F): pressure decreases linearly with increasing temperature At 60°C (140°F): 40 psi
Rated Media Temperature	Maximum 60°C (140°F)
Accuracy	± 1% of full scale over operating range
Repeatability	± 0.3% of full scale over operating range
Linearity	± 0.2% of full scale over operating range
Output Frequency	3.2 to 200 Hz, 5 msec ± 25% output pulse width
Environment temperature	0°C to 60°C (32°F to 140°F)
Enclosure rating	NEMA 4X (IP 68)

Ordering Information

Body	A	B	C	D	E	Order Number
Size	mm/inch	mm/inch	mm/inch	mm/inch	mm/inch	
2"	143/5.63	143/5.64	73/2.88	107/4.20	127/5.00	58 034 202
3"	165/6.50	173/6.83	107/4.23	119/4.68	127/5.00	58 034 203
4"	187/7.38	199/6.83	199/5.38	130/5.10	127/5.0	58 034 654

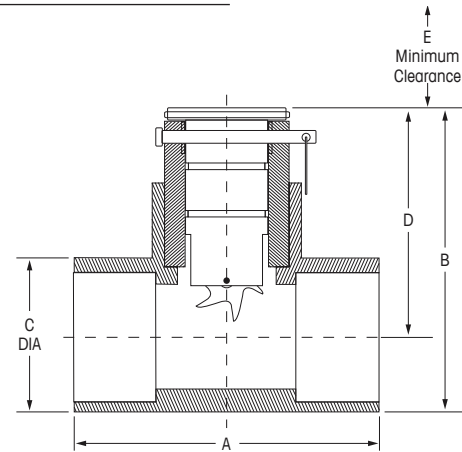

Flow Transmitter Options

Model	Mounting	Flow Channels	Order Number
M200, Flow 1-channel	¼-DIN Panel	1	30 280 748
M200, Flow 4-channel	¼-DIN Panel	4	30 280 749
M800*, Water 2-channel	½-DIN	2	58 000 802
M800*, DP Water 2-channel	½-DIN	2	58 000 806
M800*, Water 4-channel	½-DIN	2	58 000 804

*The M800 Pulse Flow Adapter (part number 58 080 116) allows an M800 ISM channel to be used with a pulse flow sensor to expand the number of flow sensors per M800 transmitter. The pulse output of the flow sensor is converted to a digital signal at the adapter and transmitted to the M800's ISM channel. By using the adapters, you can now connect up to four pulse flow sensors to a 2-channel M800 (2 ISM channels + 2 pulse channels) or six flow sensors to a 4-channel M800 (4 ISM channels + 2 pulse channels).

See p. 224 – 235 for full flow capabilities.

Vortex Flowmeters

Maintenance Free, All-Plastic Construction



PFA Version



The ultimate solution for measuring the flow rates of ultrapure water and chemicals, our range of vortex flow sensors consist of a molded unibody, available in PFA, PVC or PVDF. These sensors have no moving parts, and any potential for fluid contamination is eliminated by the corrosive-resistant all-plastic construction.

Specifications

PFA Version	
Display	4-digit LED plus high & low alarm indicators
Connections	Straight tube ends or Flaretek
Straight tube requirements	10 x diameter upstream and 2 x diameter downstream
Wetted materials	PFA Perfluoroalkoxy
Temperature	0 – 100°C (32 – 212°F)
Viscosity	For liquids more viscous than water, consult Thornton
Electrical connections	2 m (6.5 ft) cable may be extended with 22 gauge 6-conductor shielded cable up to 100 m (325 ft) for pulse input only
Enclosure	NEMA 4X, IP65
Power supply	One external 12 - 24 VDC isolated power supply is required for one or two pulse input sensor
Certificate	CE rated, certificate of accuracy included

Ordering Information Flow Vortex

PFA Versions					
Size	Flow Rate l/min (g/m)	Maximum Pressure		Order Number	
		at 20°C (68°F)	at 100°C (212°F)		
Straight Tube-end – Connections					
½"	2 – 20 (0.5 – 5)	10 bar(g) (145 psig)	7 bar(g) (100 psig)	58 034 401	
¾"	10 – 70 (2.7 – 19)	7 bar(g) (100 psig)	4 bar(g) (58 psig)	58 034 402	
1"	15 – 150 (4 – 40)	5 bar(g) (70 psig)	3 bar(g) (43 psig)	58 034 403	

Flow Transmitter Options*

Model	Mounting	Flow Channels	Order Number
M200, Flow 1-channel	¼-DIN Panel	1	30 280 748
M200, Flow 4-channel	¼-DIN Panel	4	30 280 749
M800, Waer 2-channel	½-DIN	2	58 000 802
M800, DP Water 2-channel	½-DIN	2	58 000 806
M800, Water 4-channel	½-DIN	4	58 000 804

*One external 12VDC isolated power supply is required for one or two PFA Vortex pulse input sensor(s)

Technical Data Vortex Sensors PFA Versions

Flowrate Range for PFA Vortex Flowmeters

Size	Minimum Flowrate									Max Flowrate (l/min)
	(l/min)									
cp*	0.3	0.5	0.7	1**	2	3	4	5	7	—
1/2"	0.6	1	1.4	2	4	6	8	10	14	20
3/4"	3	5	8	10	20	30	40	50	70	70
1"	4.5	7.5	10.5	15	30	45	60	75	105	150

* cp = Viscosity of measurement fluid (in centipoises)

** Viscosity of water at 20°C

Straight Tube-End Dimensions (mm)

Size	+0.30		t ± 0.5	L
	D -0.10	d -0.10		
1/2"	∅ 12.7	∅ 9.52	1.59	190
3/4"	∅ 19.05	∅ 15.88	1.59	190
1"	∅ 25.4	∅ 22.22	1.59	190

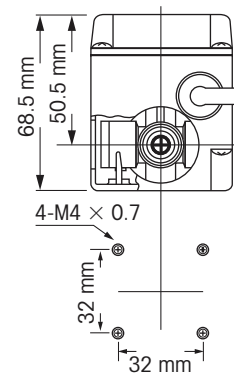
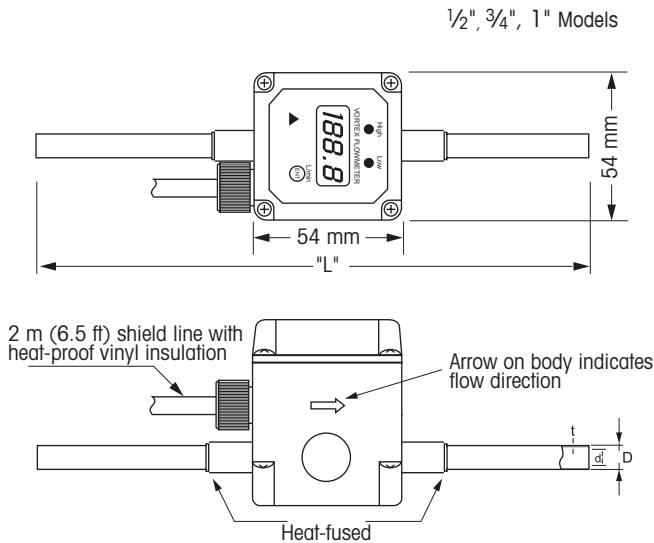

Mounting Dimensions
(for all models)

Sanitary Flow Sensors High Quality, Precision



METTLER TOLEDO Thornton's Sanitary Turbine Flow Sensors are designed and manufactured to be compliant with the ASME Bioprocessing Equipment Standard BPE-2014 for measurement of process liquids where high sanitary standards are required. ASME-BPE-2014 is the leading Standard on how to design and build equipment used in the production of biopharmaceuticals. This series includes 11 sizes, 1/4" to 3" with standard Tri-Clamp™ fittings, covering flow rates for 0.75 to 400 GPM.

Specifications

Wetted Parts	Body 316 SS, Ra 32 microinch (0.8 micrometer) finish; 17- 4PH SS rotor; PH 15- 7 Mo SS retaining rings; hard carbon composite bearings.
Certification	3A Rated, manufacturers calibration and materials certificates included.
Electrical connections	Wiring may be run up to 610 m (2,000 ft) with 3 conductor, 20 gauge, shielded cable, such as Belden 9364.
Process connections	To achieve optimum performance, maintain 3A certification and to protect the bearings from excess turbulence and damage, a minimum of 10 pipe diameters upstream and 5 pipe diameters downstream of turbine size pipe must be used.
Linearity	± 0.5% of reading*
Repeatability	± 0.1% of reading*
Temperature Range	-40°F to +325°F, process fluid with Std. Magnetic pickup coil.

* Based on manufacturer's calibration in water at 70°C

Flow Range LPM (GPM)	Tri- Clamp Fitting (C)	Turbine Size	Length (A) mm/inch	Pulse Input Order Number
2.8 – 28 (0.75 – 7.5)	3/4"	3/8"	90.4/3.56	58 034 655
6.6 – 60 (1.75 – 16)	1 – 1/2"	5/8"	90.4/3.56	58 034 656
9.5 – 110 (2.5 – 29)	1 – 1/2"	3/4"	82.6/3.25	58 034 657
15 – 227 (4 – 60)	1 – 1/2"	1"	90.4/3.56	58 034 658
30 – 492 (8 – 130)	1 – 1/2"	1 – 1/2"	116.6/4.59	58 034 659
57 – 852 (15 – 225)	2"	2"	153.9/6.06	58 034 660
95 – 1,514 (25 – 400)	3"	2 – 1/2"	254/10.00	58 034 661

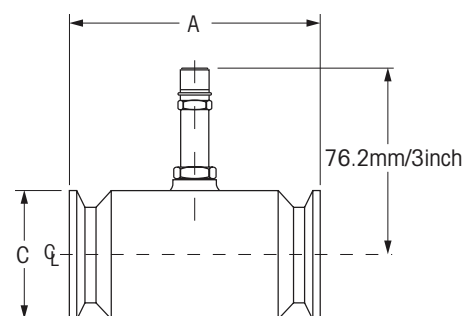

Flow Transmitter Options

Model	Mounting	Flow Channels	Order Number
M200, Flow 1-channel	1/4-DIN Panel	1	30 280 748
M200, Flow 4-channel	1/4-DIN Panel	4	30 280 749
M800*, Water 2-channel	1/2-DIN	2	58 000 802
M800*, DP Water 2-channel	1/2-DIN	2	58 000 806
M800*, Water 4-channel	1/2-DIN	2	58 000 804

*The M800 Pulse Flow Adapter (part number 58 080 116) allows an M800 ISM channel to be used with a pulse flow sensor to expand the number of flow sensors per M800 transmitter. The pulse output of the flow sensor is converted to a digital signal at the adapter and transmitted to the M800's ISM channel. By using the adapters, you can now connect up to four pulse flow sensors to a 2-channel M800 (2 ISM channels + 2 pulse channels) or six flow sensors to a 4-channel M800 (4 ISM channels + 2 pulse channels).

See p. 224 – 235 for full flow capabilities.

Total Organic Carbon (TOC) ISM Technology

Introduction to ISM Technology

The 6000TOC i Sensor uses Intelligent Sensor Management technology interfacing with the M800 Multi-parameter Analyzer/Transmitter. This technology allows the M800 to recognize the configuration and sensor parameters when connected. The M800 instrument will allow up to two or four 6000TOC i Sensors to be connected to any of the four input channels. Any remaining channels are available for use with any other ISM Sensors. The M800 also provides two pulse input channels for additional flow measurements.

The Sensor connects directly to the M800 instrument using standard patch cables. The 6000TOC i Sensor is designed to meet the requirements of today's industrial facilities with its CE and UL ratings. Combined with the M800 instrument it provides the most versatile and flexible TOC measurement platform available.

Measurement technology UV Oxidation/Differential Conductivity

Thornton 6000TOC i, 4000TOC e and 450TOC products use proven ultraviolet oxidation with differential conductivity (see Figure 1) as the method to effectively determine TOC concentrations.



High performance digital conductivity sensors provide continuous conductivity measurement before and after sample oxidation. This is accomplished using a continuous flow-through spiral quartz tube design that allows the sample to flow continuously through the sensor. This design maximizes exposure to the 185 nanometer UV light, while minimizing measurement response time and providing complete oxidation. This simple and effective design requires no reagents or chemicals and has no moving mechanical components.

The formation of hydroxyl radicals in the water during UV exposure produces a mechanism through which bonds in non-ionic organic compounds are broken and oxidation occurs to form products such as carbon dioxide and water. The carbon dioxide dissolves

in the water and forms carbonic acid, which dissociates into ionic-conductive species. This change in conductivity is associated with TOC (see Figure 2).

USP/EP and SST

In the Pharmaceutical Water production process, System Suitability Testing (SST) is an essential activity to verify the performance of a Total Organic Carbon monitoring system and to ensure its adequacy for TOC analysis.

USP and EP Requirements

In the requirements for TOC measurement, the United States Pharmacopoeia and European Pharmacopoeia have established specific Total Organic Carbon (TOC) tests as described in USP General Chapter <643> and EP Chapter 2.2.44, respectively.

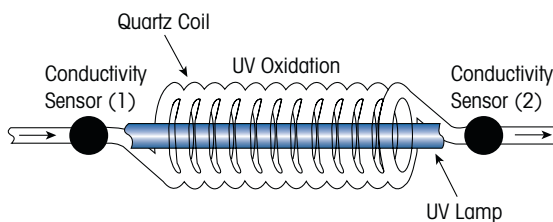

Figure 1

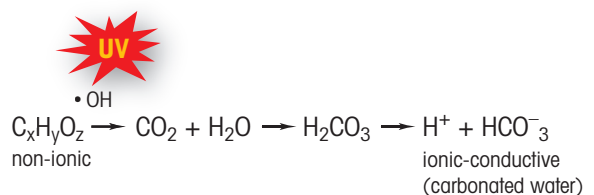

Figure 2

21CFR RecordLOC

Multi-parameter Data Integrity for Electronic Records



RecordLOC™ is the METTLER TOLEDO solution for ALCOA-compliant electronic records with data integrity for TOC, conductivity and ozone. Paired with an M800 Water 2-channel RecordLOC transmitter and any of the above mentioned sensors, RecordLOC provides audit trail controlled data integrity to your water system.

Features/Benefits

- Easy to install and maintain on a PC
- Provides ALCOA-compliant data integrity
- Three-level user accounts including Super User, Admin and User
- Encrypted and password protected audit trail
- Data is stored on a local PC, not on the transmitter for ease of access
- Multi-language support for your global organization

21CFR | RecordLOC™

Requires M800 Water 2-channel RecordLOC transmitter (30 656 182) and any of the supported sensors including 6000TOCi, PureO₃ and UniCond.

To download RecordLOC for free, visit:

► www.mt.com/RecordLOC

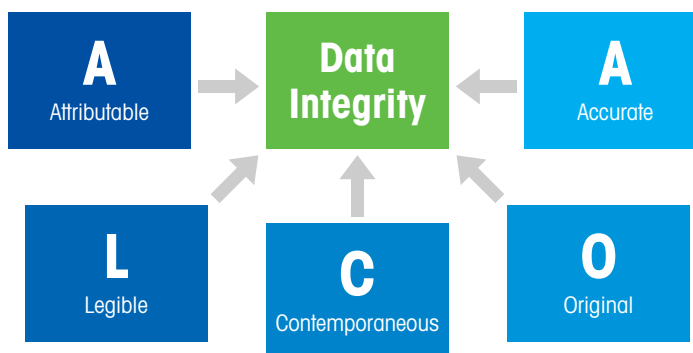

ALCOA is used in regulated industries as a framework to ensure that data is reliable and accurate.

Feature	6000TOC i	4000TOC e	450TOC
Number of TOC sensors per transmitter	4	1	N/A
Measurement Range	0.05–2000 ppbC	0.05–1000 ppbC	0.05–1000 ppbC
Transmitter	M800	M300	N/A
Multi-parameter	Yes	No	No
Plug and Measure	Yes	Yes	N/A
USP, EP, JP and Ch. P Compliant	Yes	Yes	Yes
Continuous Measurement	Yes	Yes	Yes
Automatic Flow Control	Yes	Yes	Yes
ISM Capability	Yes	No	No
Semi-Automated Cal/SST	Yes	Yes	Yes
21CFR RecordLOC	Yes	No	No

Total Organic Carbon

A TOC Sensor with Reliable Performance

Total Organic Carbon

4000TOCe

Easy to Use On-line Measurement



The enhanced 4000TOCe Sensor provides continuous on-line measurement of Total Organic Carbon in a low maintenance industrial package. In addition to using proven UV oxidation with differential conductivity to determine TOC concentration, the 4000TOCe model now features automatic flow control to ensure consistent water flow through the system.

Features/Benefits

- On-line continuous measurement for fastest response
- Advanced UV lamp design extends stability and wavelength emission over lamp life
- Sample Conditioning Coil (included) can prevent CO₂ permeation into the water sample and will stabilize inlet flow, pressure and temperature irregularities
- Local LED Sensor status indication
- Continuous flow design provides rapid detection of system changes
- No gases or reagents to handle, store or replace and no moving parts minimize routine maintenance and service intervals
- Plug and measure sensor design reduces installation and setup time
- Real-time continuous monitoring for precise data trending and better process control
- Wide dynamic operating range meets the needs of pure and ultrapure water applications
- Meets USP <643>, <645>, EP 2.2.44, Ch.P and JP requirements for the Pharmaceutical Industry

Applications

- Pure and Ultrapure water
- Pharmaceutical-grade water
- Recycle and reclaim
- Power generation

4000TOCe Sensor Ordering Information

Description	Order Number
4000TOCe Sensor, 110VAC, 50/60 Hz	30 415 866
4000TOCe Sensor, 220VAC, 50/60 Hz	30 415 867
Accessories	
Kit, Tool, TOC Sensor	58 091 520
Kit, Pipe mounting, for 1-1/2" nominal pipe size	58 091 521
High Pressure Inlet Regulator, 1/4" NPT-female	58 091 552
Outlet Drain Tube	58 091 553
Consumables and Spare Parts	
Replacement Inlet Filter Element, 60 micron (Pkg.2) (Recommended with lamp change)	58 091 551
Replacement UV Lamp (recommended every 4,500 hours of operation)	58 079 513
Kit, Fuse, Sensor PCB (for use on both 110 and 220 VAC models)	58 091 519
System Suitability Standards	58 091 526
Calibration Standards	58 091 529
Combined Calibration and SST Standards	58 091 537

For use with M300TOC Transmitters

Description	Order Number
M300TOC ¼ DIN Enclosure (Panel mounting kit included)	30 414 214
M300TOC ½ DIN Enclosure	30 414 212

▶ www.mt.com/Thornton-TOC

Specifications

4000TOCe Sensor

Measurement range	0.05 – 1000 ppbC ($\mu\text{gC/L}$)
Accuracy	± 0.1 ppb C for TOC < 2.0 ppb (for water quality > 15 M Ω -cm [0.067 $\mu\text{S/cm}$]) ± 0.2 ppb C for TOC > 2.0 ppb and < 10.0 ppb (for water quality > 15 M Ω -cm [0.067 $\mu\text{S/cm}$]) $\pm 5\%$ of measurement for TOC > 10.0 ppb (for water quality 0.5 to 18.2 M Ω -cm [2.0 to 0.055 $\mu\text{S/cm}$])
Repeatability	± 0.05 ppb C < 5 ppb, $\pm 1.0\%$ > 5 ppb
Resolution	0.001 ppbC ($\mu\text{gC/L}$)
Analysis time	Continuous
Initial response time	< 60 s
Limit of detection	0.025 ppbC

Conductivity Sensor

Conductivity accuracy	$\pm 2\%$, 0.02-20 $\mu\text{S/cm}$; Constant Sensor ^a
Cell constant accuracy	$\pm 2\%$
Temperature sensor	Pt 1000 RTD, Class A
Temperature accuracy	$\pm 0.25^\circ\text{C}$

Sample Water Requirements

Temperature	0 to 100 $^\circ\text{C}$ ^b
Particle size	< 100 micron
Minimum water quality	≥ 0.5 M Ω -cm (≤ 2 $\mu\text{S/cm}$), pH < 7.5 ^c
Flow rate	≥ 20 mL/min
Pressure	0.3 bar(g) to 6.9 bar(g) (4 to 100 psig) at sample inlet connection ^d

General Specifications

Case dimensions	280 mm (11") W \times 188 mm (7.4") H \times 133 mm (5.25") D
Weight	2.3 kg (5.0 lb)
Enclosure material	Polycarbonate plastic, flame retardant, UV and chemical resistant UL # E75645, Vol. 1, Set 2, CSA # LR 49336
Enclosure rating	NEMA 4X, IP65 Industrial environment
Ambient temperature/ Humidity rating	5 to 50 $^\circ\text{C}$ (41 to 122 $^\circ\text{F}$)/5 to 80% Humidity, non-condensing
Power requirements	100 – 130 VAC or 200 – 240 VAC, 50/60 Hz, 25 W Maximum
Local indicators	Four LED lights for Fault, Error, Sensor Status and UV Lamp ON
Ratings/approvals	CE Compliant, UL and cUL (CSA Standards) listed, Conductivity and temperature sensors traceable to NIST, ASTM D1125 and D5391. Meets ASTM D5173 Standard Test Method for On-line Monitoring of Carbon Compounds in Water by UV Light Oxidation

Sample Connections

Inlet connection	3 mm (0.125") O.D. (2 m (6") FDA compliant PTFE tubing supplied)
Outlet connection	6 mm (0.25") O.D. Barb connection (1.5 m (5") flexible tubing provided)
Inlet filter	316 SS, in-line 60 micron
Wetted parts	316 SS/Quartz/PEEK/Titanium/PTFE/EPDM/FFKM
Wall mount	Standard, mounting tabs provided
Pipe mount	Optional, with pipe-mount bracket accessory for nominal pipe sizes 2.5 cm (1")
Maximum sensor distance	91 m (300')

^a Readout in equivalent S/m ranges selectable at M300TOC.

^b Temperature above 70 $^\circ\text{C}$ requires Sample Conditioning Coil (included).

^c For power plant cycle chemistry samples, pH may be adjusted by measurement after cation exchange.

^d Process pressure above 5.9 bar(g) (85 psig) requires optional High Pressure Regulator p/n 58 091 552.

Dimensions

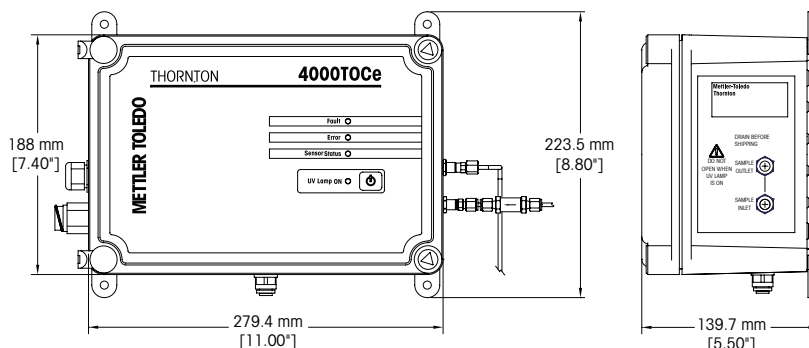

Total Organic Carbon

A TOC Sensor with Real-Time Continuous Measurement

Total Organic Carbon

6000TOC i

On-line, Fast and Continuous



The 6000TOC i total organic carbon sensor provides true continuous measurement, refreshing every second, for immediate detection of organic contamination. Its dependable and reliable design uses proven UV oxidation technology for real-time TOC monitoring of your critical water systems. Easily and efficiently monitor TOC levels from post RO waters to point-of-use so you will never miss an excursion. Constructed with the user in mind, its intuitive interface and flexible Plug and Measure design requires no reagents or chemicals for operation.

ISM®



Features/Benefits

- On-line continuous measurement
- Meets USP <643>, <645>, EP 2.2.44, Ch.P and JP requirements for the Pharmaceutical Industry
- Semi-automated Calibration and System Suitability Test
- Intelligent Sensor Management (ISM) Interface
- Intelligent diagnostics with iMonitor
- Peak, Average and Rate-of-Change TOC measurement for compliance monitoring
- Compatible with M800 multi-parameter transmitter
- Install up to four TOC sensors to one M800 transmitter
- USB printer capable
- USB for data logging
- Automated flow control
- At-a-glance LED status
- Universal Power Ballast
- 21CFR Part 11 Data Integrity option when paired with an M800 Transmitter and RecordLOC software (see page 183)

True Continuous Measurement

With an initial response rate of less than a minute and measurement updates every second, the 6000TOC i is ideal in all pure water applications where rapid detection of TOC changes is critical.

Stable and reliable analysis

With highly stable and reproducible TOC measurements, you can be confident that you have the control over your water system that is required to meet regulatory and internal water quality specifications.

Verifiable system performance Intelligent Sensor Management (ISM) advanced diagnostics help ensure your sensor performs optimally at all times.

Supports regulatory compliance

For regulated industries, the 6000TOC i Sensor and M800 Transmitter provide the tools necessary to be compliant. They satisfy the requirements of all major global pharmacopeias for TOC instrumentation, including USP, EP, JP, ChP and IP. ALCOA-compliant audit trail for data integrity when paired with an M800 Water 2-channel RecordLOC transmitter and RecordLOC software (see page 203).

► www.mt.com/6000TOCi

Specifications

6000TOCi Sensor

Measurement range	0.05 – 2000 ppbC (µgC/L)
Accuracy	±0.1 ppbC for TOC <2.0 ppbC (for water quality >15 MΩ-cm [0.067 µS/cm]) ±0.2 ppbC for TOC >2.0 ppbC and <10.0 ppbC (for water quality >15 MΩ-cm [0.067 µS/cm]) ±5% of measurement for TOC >10.0 ppbC (for water quality 0.5 to 18.2 MΩ-cm [2.0 to 0.055 µS/cm])
Repeatability	±0.05 ppbC <5 ppbC, ±1.0% >5 ppbC
Resolution	0.001 ppbC (µgC/L)
Analysis Time	Continuous
Initial Response Time	<60 seconds
Update Rate	1 second
Limit of Detection	0.025 ppbC

Specifications

Conductivity Sensor

Conductivity Accuracy	±2%, 0.02 – 20 µS/cm ±3%, 20 – 100 µS/cm*
Cell Constant Accuracy	±2%
Temperature Sensor	Pt1000 RTD, Class A
Temperature Accuracy	±0.25°C

Sample Water Requirements

Temperature	0 to 100°C (32 to 212 °F)**
Particle Size	<100 micron
Minimum Water Quality	≥0.5 MΩ-cm (≤ 2 µS/cm), pH <7.5***
Flow Rate	>8.5 mL/min
Pressure	0.3 bar(g) to 13.6 bar(g)/4 to 200 psig at sample inlet connection****

General Specifications

Case Dimensions	302.75 mm (11.9") W × 229.8 mm (9") H × 144.7 mm (5.7") D
Weight	5 kg (11.0 lb)
Enclosure Rating	IP55
Enclosure Material	Ignition Resistant Polystyrene Resin meeting UL 94V-0, Painted Aluminum
Ambient Temperature/Humidity Rating	5 to 50°C (41 to 122 °F)/5 to 80% Humidity, non-condensing
Power Requirements	100 – 240 VAC, 50 – 60 Hz, 25W
Local Indicators	Four LED lights for Fault, Error, Sensor Status and UV Lamp ON
Ratings/Approvals	CE Compliant, UL and cUL (CSA Standards) listed. Conductivity and temperature sensors traceable to NIST, ASTM D1125 and D5391. Meets ASTM D5173 Standard Test Method for On-Line Monitoring of Carbon Compounds in Water by UV Light Oxidation

Installation/Power/Enclosure

Inlet Connection	3 mm (0.125") O.D. (1.83 m [6 ft] FDA compliant PTFE tubing supplied)
Outlet Connection	3 mm (0.125") O.D. (165 mm [6.5"] fixed 316 SS tube provided)
Inlet Filter	316 SS, inline 60 micron
Wetted Parts	316 SS/Quartz/PEEK/Titanium/PTFE/EPDM
Wall Mount	Standard, mounting bracket provided
Maximum Sensor Distance	91 m (300 ft)

* Readout in equivalent S/m ranges selectable at M800

** Temperature above 70 °C requires Sample Conditioning Coil (included)

*** For power plant cycle chemistry samples, pH may be adjusted by measurement after cation exchange.

**** Process pressure above 5.9 bar(g)/85 psig requires optional High Pressure Regulator p/n 58 091 552.

Specifications subject to change without notice.

Total Organic Carbon

A TOC Sensor for Critical Water Release

Ordering information

Sensor	Order no.
6000TOC i Sensor, 100 – 240 VAC 50 – 60 Hz*	30 472 150
6000TOC i Sensor, Low ppb calibration, 100 – 240 VAC 50 – 60 Hz*	30 472 151
Transmitter	
M800 Water, 2-channel	58 000 802
M800 DP, 2-channel	58 000 806
M800 Water, 2-channel RecordLOC	30 656 182
M800 Ethernet/IP Water, 2-channel	30 530 028
M800 Water, 4-channel	58 000 804
M800 Ethernet/IP Water, 4-channel	30 530 029
Accessories	
Pump Module, 6000TOC i	30 472 152
Inlet Filter Assembly, High Capacity	58 091 550
High Pressure Regulator	58 091 552
TOC Cation Resin Column Kit	30 610 550
Spare TOC Cation Resin Cartridge	30 612 727
Accessories – Cords	
Patch Cord, 1.5 m (5 ft)	58 080 271
Patch Cord, 3.0 m (10 ft)	58 080 272
Patch Cord, 4.5 m (15 ft)	58 080 273
Patch Cord, 7.6 m (25 ft)	58 080 274
Patch Cord, 15.2 m (50 ft)	58 080 275
Patch Cord, 30.5 m (100 ft)	58 080 276
Patch Cord, 45.7 m (150 ft)	58 080 277
Patch Cord, 61.0 m (200 ft)	58 080 278
Patch Cord, 91.4 m (300 ft)	58 080 279
Consumables & Spare Parts	
Replacement UV Lamp	58 079 513
Calibration Standards	30 472 083
System Suitability Test Standards	30 472 084
Combined Calibration and System Suitability Test Standards	30 472 085
Calibration Standards for Extended Range Calibration	30 472 086
Combined Calibration and System Suitability Test Standards for Extended Range Calibration	30 472 087

* Low ppb calibration method optimizes 6000TOC i for very low ppb levels of TOC as required in semiconductor and microelectronics waters.

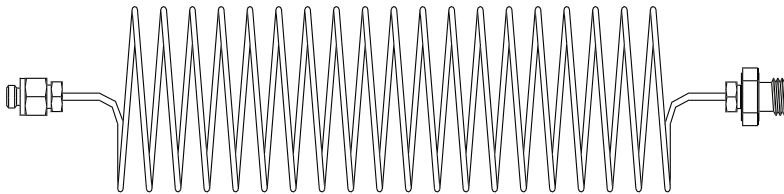

Did You Know

The sample conditioning coil optimizes the 6000TOC i sensor performance under adverse conditions such as:

- High sample temperature
- A highly humid environment
- Varying inlet pressure

It also prevents CO₂ ingress into the sample.

System Suitability Testing

Since the 6000TOC*i* sensor provides continuous monitoring, the system suitability test can be performed far faster than other TOC measurement technologies which rely on lengthy batch measurement or laboratory analysis. During the System Suitability Test, the operation of the instrument is identical to normal operating conditions with no extra oxidation cycle times. The solutions are easily introduced into the system, and results are available in minutes.

The system suitability test kit from Thornton provides the equipment needed to perform a system suitability test on the 6000TOC*i* Sensor. The system suitability test kit is designed for use with the system suitability standards solutions kit available from Thornton. The Solutions Kit includes one bottle of 500 ppb sucrose, one bottle of 500 ppb 1,4-benzoquinone and two bottles of reagent TOC water. The solutions are produced from USP Reference Standards for assured consistency, quality and compliance.

Dimensions

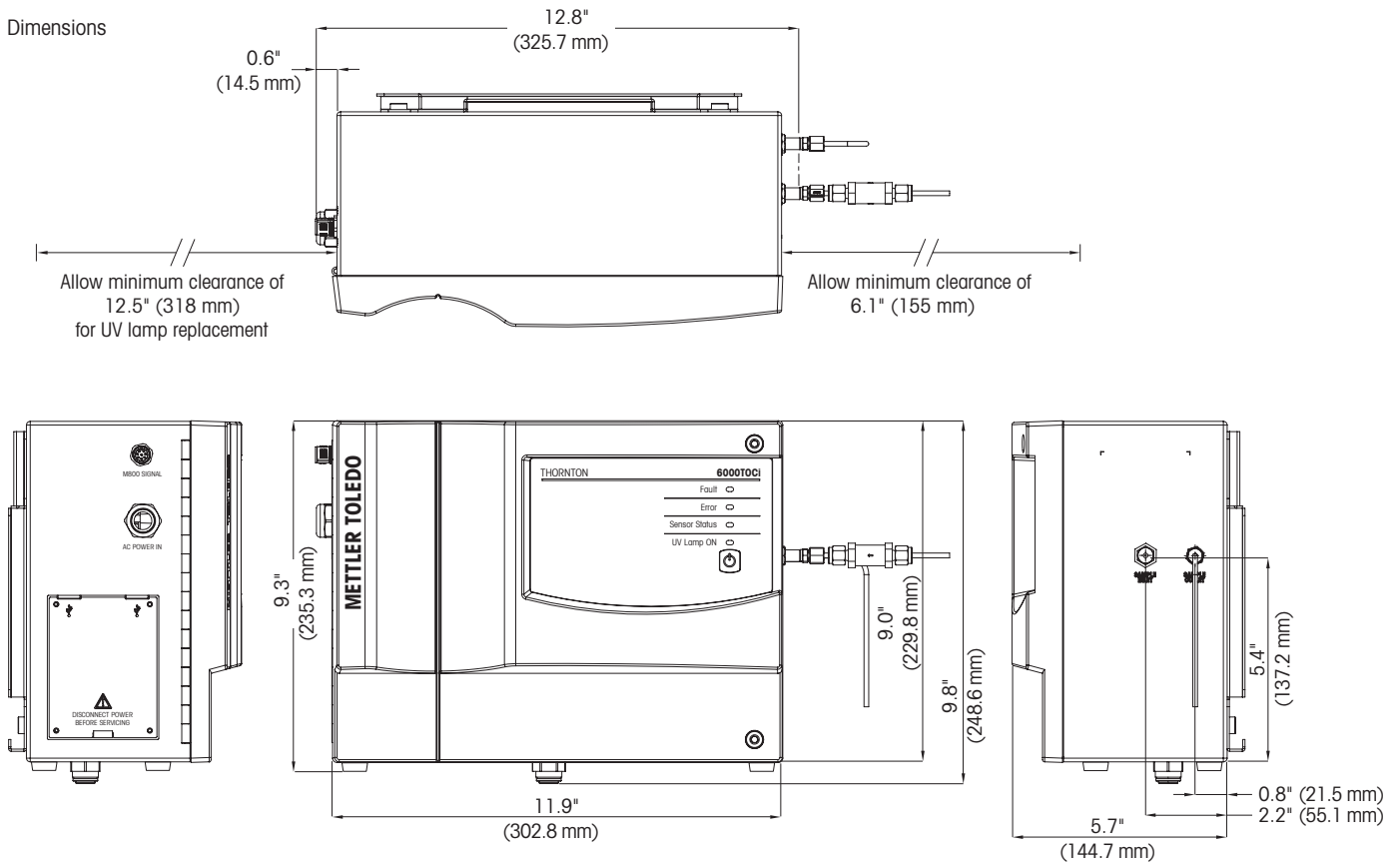

450TOC Portable TOC Measurement



The 450TOC Total Organic Carbon analyzer from METTLER TOLEDO Thornton offers the fastest response to TOC changes available in a portable TOC system. With its robust, portable design the 450TOC is an ideal tool for multi-point TOC measurement for point-of-use monitoring, water system diagnostics, and maintenance verification.

Portable, Real-time TOC Measurement

- Reduce system and component verification time by 80% with portable, real-time total organic carbon analysis
- Ensure 100% system compliance with fast, simple and easy point-of-use monitoring
- Reduce system diagnostics time by 80% with fast, on-the-spot test results for TOC and conductivity
- Quickly capture and analyze results with on-board USB stick data collection and simple export to spreadsheet programs
- Eliminate costly sampling errors by bringing the measurement directly to the sampling point

Other Highlights

- Continuous measurement technology for superior system profiling and performance trending
- USB printer support for hard-copy record keeping
- Compliant with USP, EP, Ch P and JP

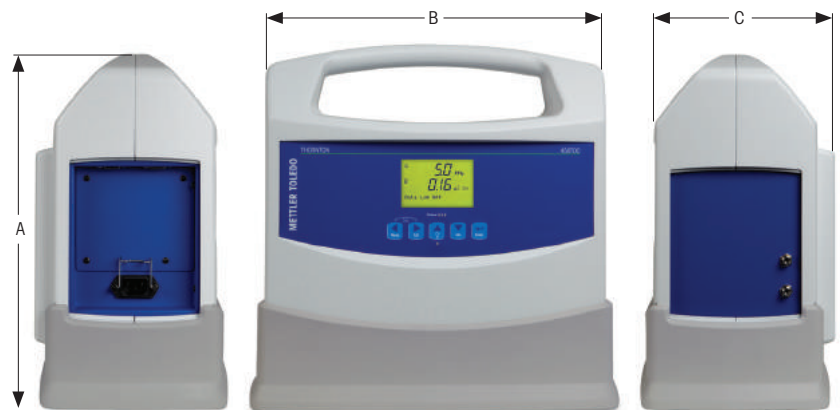

Dimensions	With Base	Without Base
A	349 mm (13.75")	324 mm (12.75")
B	358 mm (14.1")	334 mm (13.15")
C	192 mm (7.56")	185 mm (7.30")

www.mt.com/450TOC

Specifications

450TOC Sensor	
Measurement range	0.05 – 1000 µgC/L (ppbC)
Accuracy	±0.1 ppbC for TOC < 2.0 ppb (for water quality > 15 MΩ-cm) ±0.2 ppbC for TOC > 2.0 ppb and < 10.0 ppb (for water quality > 15 MΩ-cm) ±5 % of measurement for TOC > 10.0 ppb (for water quality 0.5 to 18.2 MΩ-cm)
Repeatability	±0.05 ppbC < 5 ppb, ±1.0% > 5 ppb
Resolution	0.001 ppbC (µgC/L)
Analysis time	Continuous
Initial response time	< 60 s
Limit of detection	0.025 ppbC
Conductivity Sensor	
Conductivity accuracy	±2 %, 0.02 to 20 µS/cm; ±3 %, 20–100 µS/cm
Cell constant accuracy	±2 %
Temperature sensor	Pt 1000 RTD, Class A
Temperature accuracy	±0.25 °C
Sample Water Requirements	
Temperature	0 to 70 °C
Particle size	< 100 micron
Minimum water quality	≥ 0.5 MΩ-cm (≤ 2 µS/cm), pH < 7.5*
Flow rate	20 mL/min
Pressure	0.3 to 5.8 bar (4 to 85 psig) at sample inlet connection
General Specifications	
Overall dimensions	334 × 185 × 324 mm (13.15" L × 7.3" W × 12.75" H)
Sample connections	3 mm (0.125") O.D. (2 m {6"} FDA compliant PTFE tubing supplied)
Weight	With base: 7.0 kg (15.4 lb); without base: 6.1 kg (13.6 lb)
Wetted parts	316 SS/quartz/PEEK/titanium/PTFE/silicone/FFKM/EPDM
Power requirements	100–240 VAC, 50/60 Hz, 40 W maximum
Ratings/approvals	CE Compliant, cULus Listed. Conductivity and temperature sensors traceable to NIST and ASTM D1125 and D5391 Meets ASTM D5173 Standard Test Method for On-Line Monitoring of Carbon Compounds in Water by UV Light Oxidation

* For power plant cycle chemistry samples, pH may be adjusted by measurement after cation exchange.

Specifications subject to change without notice.

450TOC Portable Analyzer Ordering Information

Description	Order Number
450TOC Portable Analyzer	58 036 041
Accessories	Order Number
450TOC protective base	58 091 585
Kit, ISM calibration and System Suitability Test (SST and calibration standards sold separately)	58 091 566
Stand, calibration and System Suitability Test kit	58 091 586
Case, 450TOC storage and transport, hard walled	58 091 587
High pressure regulator	58 091 552

TOC Pump Module

Valveless Design, Drift-Free Performance



The Pump Module uses a precision, positive displacement pump to provide a highly stable, metered flow of process water to the TOC sensor to ensure reliable and consistent TOC measurement performance. This accessory is recommended for applications where system pressure is either too low to provide adequate flow through the TOC sensor, or for low pressure applications where system pressure may vary routinely during operation. The Pump Module is ideally suited for applications such as distillation, RO permeate, CIP and pharmaceutical washing.

Features Overview

- Positive displacement pumping mechanism
- Flow rate independent of supply pressure
- Requires only a wetted-suction for operation
- Flow pre-set for 20 ml/min or 8.5 ml/min
- Universal AC supply



Installation Diagram

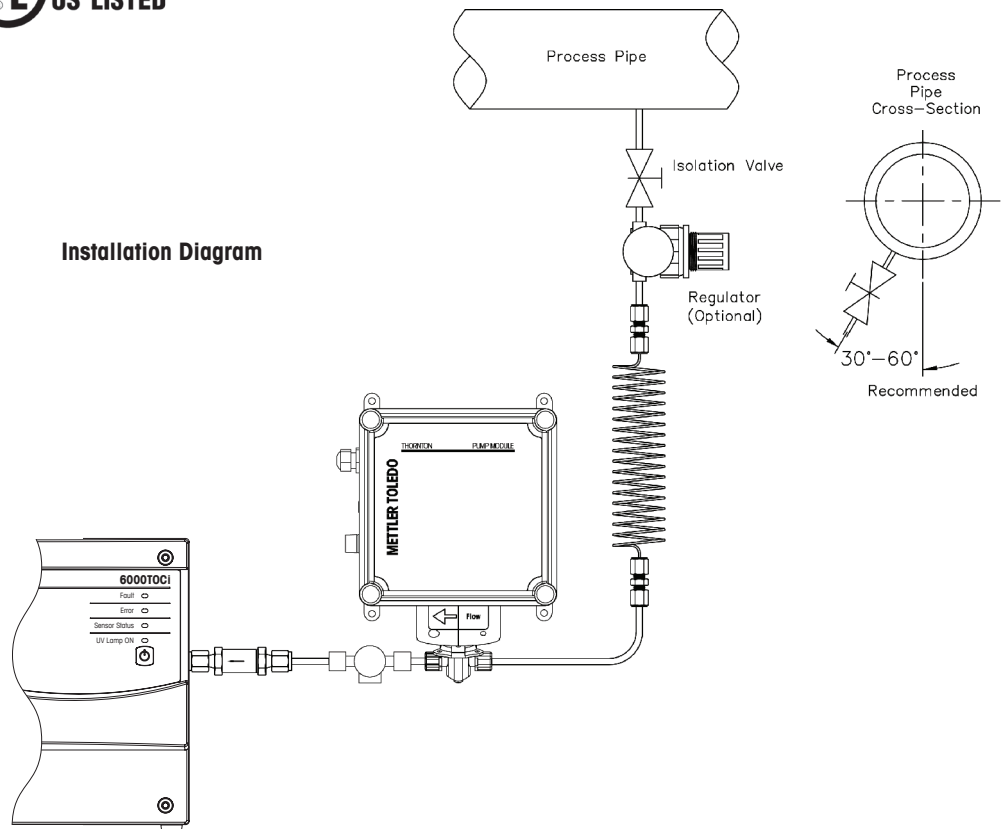

www.mt.com/Thornton-TOC

Ordering Information

Description	Order Number
Pump Module 20 ml/min (for use with the 4000TOCe sensor)	58 091 565
Pump Module 8.5 ml/min (for use with the 6000TOCi sensor)	30 472 152
Pump Module Spare Parts	
Pump Seal Replacement Kit	58 091 020
Replacement Fitting Kit	58 091 021
Replacement Fuse (Fuse rating 250V 0.375A 5 × 20 mm Type 'T' [Time Log])	58 091 024
Pulsation Dampener with Interconnect	58 091 025
Pulsation Dampener Bellows Replacement Kit with Seal	58 091 026

Specifications

Sample Water Requirements	
Temperature	0 to 100 °C*
Particle size	< 100 micron
Flow rate	20 ± 0.5 ml/min; 8.5 ± 0.25 ml/min
Pressure	Flooded suction to 0.69 bar(g) (10 psig) at sample inlet connection
General Specifications	
Overall dimensions	188 mm (7.4") W × 188 mm (7.4") H × 133 mm (5.25") D
Sample connections	Inlet 3 mm (0.125") O.D. (2 m (6') FDA compliant PTFE tubing supplied) Outlet 3 mm (0.125") O.D.
Weight	2.3 kg (5.0 lb.)
Ambient temperature/Humidity rating	5 to 50 °C/5 to 80 % humidity, non-condensing
Enclosure material	Polycarbonate plastic, flame retardant, UV and chemical resistant UL #E75645, Vol.1, Set 2, CSA #LR 49336
Power requirements	100–240VAC, 50/60 Hz, 0.2A
Wall mount	Standard, mounting tabs provided
Ratings/Approvals	CE Compliant, UL and cUL (CSA Standards) listed. Not NEMA or IP rated

* Temperature above 70 °C requires Sample Conditioning Coil p/n 58 079 518

Dimensions

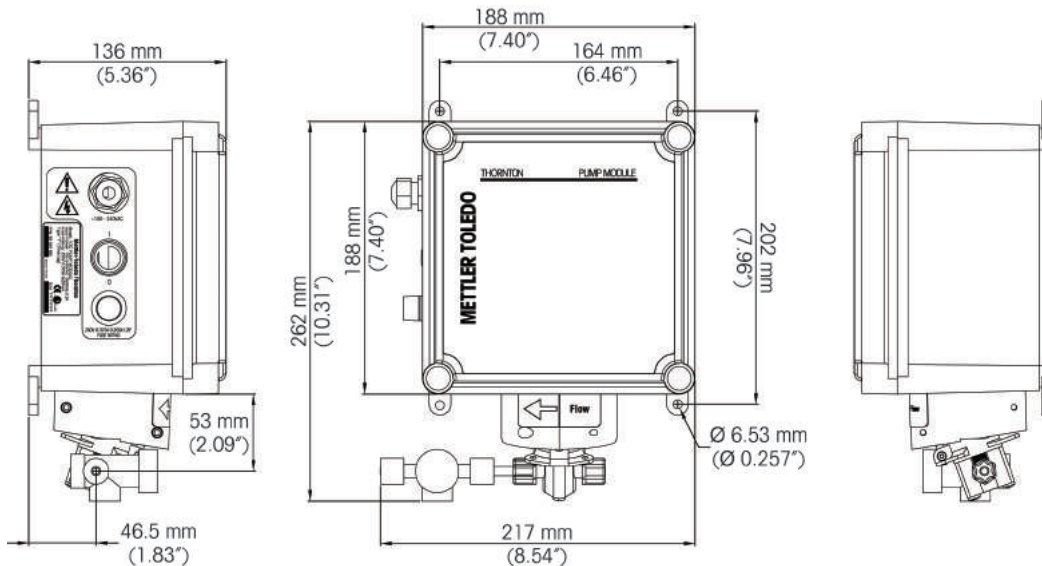

Microbial Detection Analyzer

Real-time Monitoring of Microbial Contamination

Microbial Contamination

7000RMS Microbial Detection Analyzer

Continuous, At-line and Dependable

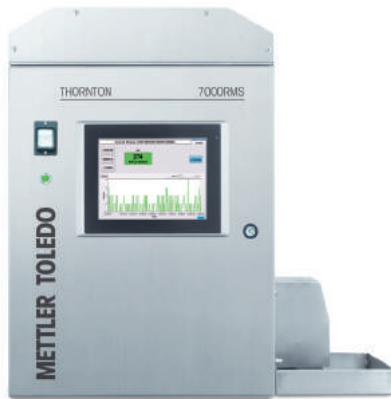

METTLER TOLEDO Thornton's 7000RMS™ (Real-time Microbial System) is an at-line analyzer for real-time measurement of microbial contamination (bioburden) in Pharmaceutical Waters. Advanced, laser-induced fluorescence and Mie scattering measurement technology provides immediate detection and quantification of microorganisms. The compact analyzer overcomes limitations of growth-based technologies that are dependent on incubation conditions, growth media, reagents and time.

The 7000RMS enables risk reduction and greater process control, and offers significant costs savings from the combined decrease in laboratory testing and false-positive results.

Features/Benefits

- Continuous results every 2 seconds, no incubation or preparation needed
- Laser-induced fluorescence allows for the measurement of AFU
- Detection is not based on organisms forming a colony
- Increase process control by monitoring/reacting to water system trends prior to an out-of-specification event
- Reduce risk of releasing contaminated water
- Convenient touchscreen display with intuitive user interface
- Monitor at-line
- Alarms for alert, action and breach limits
- SCADA connectivity, analog output, Ethernet and Modbus compatible

Typical Applications

Continuous monitoring of PW, WFI and UPW

- Distribution loops
- Sub loops
- Return loops
- Recirculating storage tanks
- Post purification before storage
- Sampling points

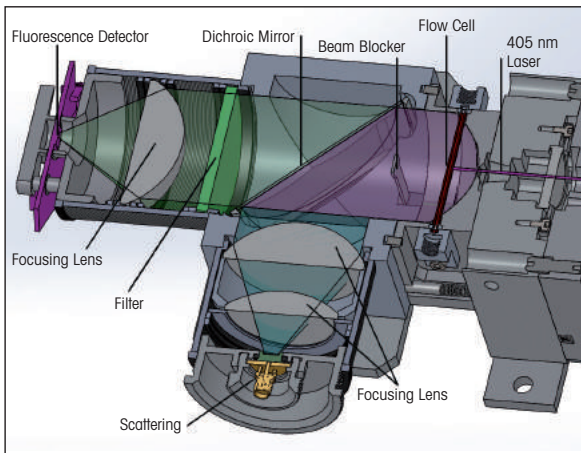

Cross-section drawing of the optical detection system

www.mt.com/7000RMS

Specifications

700RMS Analyzer

General Specifications

Flow rate	30 mL/min
Detection limit	1 AFU (Auto Fluorescent Units)
Minimum detection size	≥ 0.3 µm
Measurement range	0–10,000 AFU/mL
Analysis time	Continuous
Response time	2 seconds (1 mL)
Data communication	<ul style="list-style-type: none"> – Ethernet - standard RJ 45/Wi-Fi capable – SCADA connectivity via Modbus TCP – Analog output channels; 4–20 mA standard, with configurable output ranges – USB

Water Requirements

Temperature (non-condensing)	5–90 °C (41–194 °F)*
Inlet pressure	2–5.5 bar(g) (20–80 psig)**1
Type/Quality	Purified Water (PW), Ultrapure Water (UPW), Water for Injection (WFI)

Power/Installation/Enclosure

Power requirements	100–240 VAC, 50–60 Hz, 5A Use the power cord included with the instrument 2.5 m (8.2 ft) cord length provided standard
Monitoring location	At-line to drain
Ambient temperature (non-condensing)	0–37 °C (32–98.6 °F)*
Inlet connection	3 mm (0.125") O.D.
Outlet connection	3 mm (0.125") O.D.
Wall mount	Anti-vibration shelf required (P/N 58 079 700)
Enclosure material	Stainless steel
Physical dimensions (W × H × D)	56.4 cm × 61.6 cm × 30.5 cm (22.2" × 24.25" × 12")
Weight	33.3 kg (73.4 lbs)

Environmental Conditions

Use	Indoor use
Altitude	Up to 2000 m (6562 ft)
Environmental Temperature	5–35 °C (41–95 °F)
Environment	Pollution degree 2
Humidity (non-condensing)	80% maximum relative humidity up to 31 °C (87.8 °F) decreasing linearly to 50% relative humidity at 40 °C (104 °F)
Voltage	MAINS supply voltage fluctuations up to ±10% of the nominal voltage of 100–240 VAC 50–60 Hz TRANSIENT OVERVOLTAGES: up to levels of OVERVOLTAGE CATEGORY II TEMPORARY OVERVOLTAGES occurring on the MAINS SUPPLY

* Temperature below 15 °C or above 45 °C requires Sample Conditioning Coil (included)

** Process pressure above 80 psig (5.5 bar(g)) requires optional High Pressure Regulator (P/N 58 091 552). For Process inlet pressure below 2 bar (20 psig use the 700RMS Pump Module Accessory (P/N 30 616 889) [Min pressure ≥ 5psig (0.34 bar(g)); Max pressure ≤ 50psig (3.44 bar(g))]

¹ Calibration, cleaning and grab sample requires sample pressure of 0 psig (0 bar(g))



The 700RMS analyzer is certified as a Class 1 laser product.
The 700RMS unit contains a Class 3B Laser System, as specified by IEC 60825-1 Ed.3 (2014).

Ordering Information

Description	Order Number
700RMS Microbial Detection Analyzer	58 045 001
700RMS Pump Module Accessory	30 616 889

2300Na Sodium Analyzer

High Sensitivity, Low Maintenance



The METTLER TOLEDO Thornton 2300Na Sodium Analyzer offers a new approach for a traditional measurement in pure/ultrapure water treatment and power cycle chemistry monitoring. This analyzer provides assurance of water purity to minimize corrosion and maximize water production during power generation. It also ensures water purity in microelectronics production through early detection of breakthrough in cation resin during ultrapure water treatment. Early detection of trace contamination is enabled with minimal operator supervision.

Features/Benefits

- Fully automatic, unattended calibration: ensures reliable operation while saving technician time
- Reagent addition confirmation by pH: ensures reliable measurement results
- Convenient grab sample measurement: for additional samples and QC checks for other areas of the plant
- Slow and complete reagent consumption: saves reagent costs and eliminates waste disposal issues
- Simultaneous display of sodium, adjusted pH, temperature and calibration progress: provides convenient analyzer and sample status at a glance, saving operator time
- Automated electrode conditioning with each calibration: minimizes the need for electrode etching
- Choice of two enclosures: full locking door for dirty plant environments or with controls conveniently accessible for clean sample rooms
- Four analog outputs for sodium, pH and temperature with choice of scaling: enables full integration into data acquisition or control systems

Typical Applications

- Ultrapure water monitoring at sub-ppb sodium levels
- Cation exchange monitoring in pure water treatment detects the first breakthrough of sodium
- Power steam quality monitoring protects turbines from sodium attack
- Power condensate monitoring detects small leaks early to allow time to plan corrective action

Specifications

Measurements

Response time (90%)	5 min
Update rate	Once per second
Reagent consumption	Diisopropylamine (DIPA), approximately 1 L per 3 months; more at higher temperatures and for cation exchange samples
Sample pH	2.5–12
Sample flow rate	> 40 mL/min (> 20 mL/min for cation exchange samples), excess to drain
Sample temperature	5–50 °C (41–122 °F)
Sample pressure	0.3–7 bar(g) (5–100 psig)
Calibration	Automatic, unattended 3-point known addition; manual 1- or 2-point
Electrode conditioning	Part of auto-cal sequence
Grab sample measurement	Included
Range, temperature	0–100 °C (32–212 °F)

Outputs

Analog outputs	For sodium, conditioned pH, temperature; four powered 0/4–20 mA, 22 mA alarm, 500 ohm max load, not for use with externally powered circuits
Analog output scaling	Linear, bi-linear, logarithmic (1,2,3 or 4 decades) or auto ranging
Analog output accuracy	±0.05 mA
Relay contacts	Two unpowered, SPDT, 250 VAC/30VDC, 3 A resistive freely assignable to setpoints for sodium, pH, temperature; other relays used for auto-cal

Installation/Power/Enclosure

Operator interface	4-line backlit LCD, 5 tactile keys; simultaneous display of sodium, conditioned pH, auto-cal status (temperature optional)
Connections	Sample inlet: 1/4" or 6 mm OD tube SS compression fitting Drain hose: 19 × 25.4 mm (3/4 × 1"), 2 m (6 ft) length included
Power	100–240 VAC, 50–60 Hz, 25 W; on power loss all settings are retained without batteries
Dimensions HWD	Enclosures: 900 × 450 × 190 mm (35.4 × 17.7 × 7.5")
Weight	27 kg (60 lbs)
Ambient operating temperature	10–45 °C (50–113 °F)
Humidity	10–90% non-condensing
Ratings/approvals	CE, cULus

Ordering Information

Description	Order No.
2300Na Sodium Analyzer, with full dust & water resistant enclosure	58 042 002
Required Startup Kit	58 091 233*
1 L of 100 ppm calibration standard solution, 250 mL of 7 and 10 pH buffer solutions and etch solutions	
Diisopropylamine (DIPA)	58 140 017
Ammonium Hydroxide 30%	58 091 114

* Diisopropylamine (DIPA) reagent to be sourced locally.

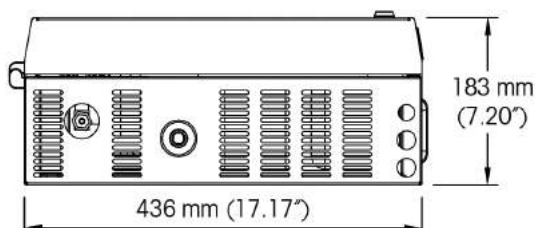

2301Na Sodium Analyzer

Accurate and Reliable Measurement, Solid Value

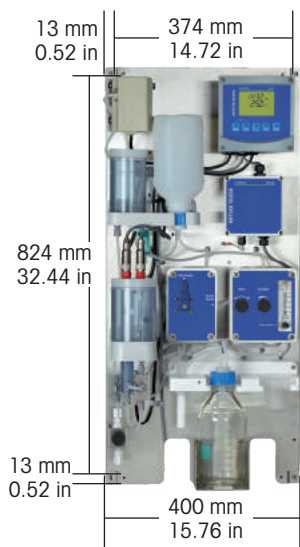

The METTLER TOLEDO 2301Na Sodium Analyzer offers an open panel-mounted design for pure water treatment projects. This analyzer features a measurement range starting at 0.01 ppb for trace measurement applications. This low-maintenance analyzer has a manual calibration process to ensure accurate measurements and to help you identify cation resin breakthrough during pure water treatment. This analyzer offers add-on features to enhance capabilities according to your project's needs.

Features/Benefits

- Wide measurement range: 0.01 ppb-100,000ppb assures early detection of trace contamination
- Choice of reagent, DIPA or Ammonium Hydroxide to better comply with plant safety requirements
- pH check verifies reagent delivery assuring reliability of measurement
- Two models available, a panel-mounted assembly or lockable full-door enclosure
- Controlled, efficient reagent consumption eliminates waste disposal issues
- Low maintenance ensures low cost of ownership
- Grab sample capability is available as an add-on option for testing samples in multiple areas of the plant

Specifications

Measurements	
Range, sodium	0.01 – 100,000 ppb or equivalent ppm, auto ranging
Resolution, sodium	4 digits with decimal, auto ranging; 0.001 ppb in lowest range
Accuracy, sodium	± 10 % of reading ± 0.1 ppb, typical; using DIPA as reagent ± 10 % of reading ± 1 ppb, typical; using ammonium hydroxide as reagent
Response time (90 %)	5 min
Update rate	Once per second
Reagent consumption	Diisopropylamine (DIPA), or ammonium hydroxide, approximately 0.7 L fillings per 2 months; more at higher temperatures and for cation exchange samples
Sample pH	2.5 – 12
Sample flow rate	> 40 mL/min (> 20 mL/min for cation exchange samples excess to drain)
Sample temperature	5 – 50 °C (41 – 122 °F)
Sample pressure	0.3 – 7 bar(g) [5 – 100 psi(g)]
Calibration	Manual 3-point known addition; manual 1- or 2-point
Grab sample measurement	Available option
Range, pH	0 – 14 pH, reagent conditioned sample
Range, temperature	0 – 100 °C (32 – 212 °F)

Specifications

Outputs

Analog outputs	For sodium, conditioned pH, temperature; four powered 0/4–20 mA, 22 mA alarm, 500 ohm max load, not for use with externally powered circuits
Analog output scaling	Linear, bi-linear, logarithmic (1,2,3 or 4 decades) or auto ranging
Analog output accuracy	±0.05 mA
Relay contacts	Two unpowered, SPDT, 250 VAC/30 VDC, 3 A resistive freely assignable to setpoints for sodium, pH, temperature

Installation/Power/Enclosure

Operator interface	4-line backlit LCD, 5 tactile keys; simultaneous display of sodium, conditioned pH, cal status (temperature optional)
Connections	Sample inlet: 1/4" or 6 mm OD tube SS compression fitting Drain hose: 19 × 25.4 mm (3/4 × 1"), 2 m (6 ft) length included
Power	100–240 VAC, 50–60 Hz, 25 W; on power loss all settings are retained without batteries
Dimensions HWD	851 × 450 × 165 mm (33.5 × 15.75 × 6.5")
Weight	4.5 kg (10 lbs)
Ambient operating temperature	5–50 °C (41–122 °F)
Humidity	10–90% non-condensing
Ratings/approvals	CE, cULus, IP 65, UKCA

Ordering Information

Description	Order No.
2301Na Sodium Analyzer panel assembly	58 042 003
2301Na Sodium Analyzer with full door enclosure	58 042 004

Accessories and Consumables

Consumables kit 1 year – Includes sodium and pH electrodes, air filters, sample filter, diffusion tubing, calibration kit, 7 and 10 pH buffer solutions	58 091 111
Calibration kit 1 year – Includes 120 mL of 100 ppm calibration standard, 60 mL of conditioning solution, etch kit	58 091 108
Diisopropylamine (DIPA)	58 140 017
Ammonium Hydroxide 30 %	58 091 114

Key Power Applications

- **Make Up Water:** Detects cation breakthroughs of sodium ions signaling exhaustion of cation resin.
- **Condenser and Polisher:** Warns of cation breakthrough and condenser leakage.
- **Economizer:** Detects sodium carryover into inlet water before it enters the boiler.
- **Superheater:** Detects sodium carryover into steam to protect turbines.



Did You Know

SQ144 and SQ148 Sequencers offer the capability to measure up to 8 sample streams with a single sodium, silica, chloride/sulfate analyzer. Please speak with your METTLER TOLEDO representative to learn more.

2850Si Silica Analyzer

Intelligent, Flexible, Compact



The METTLER TOLEDO Thornton 2850Si Silica Analyzer is a compact and reliable on-line analyzer designed for measuring silica in pure/ultrapure water treatment and power cycle chemistry monitoring. It supports early detection of trace contamination with minimal operator supervision, proactively monitors reagent usage and reports time to maintenance. This analyzer offers optional built-in sequencing to support multiple sample streams and phosphate monitoring to ensure sufficient levels are maintained for optimal boiler water treatment.

Features/Benefits

- Automatic, unattended calibration provides excellent repeatability and saves operator time
- Automatic zeroing with every measurement ensures measurement stability
- Convenient grab sampling allows quality testing of remote samples
- Intelligent internal analytics ensure peak performance and minimal downtime
- Configurable simultaneous display of parameters including silica/phosphate levels and measurement timing
- Analog output with choice of scaling for integration into data acquisition system
- Available as panel assembly or with full enclosure that protects reagent containers and components from plant environment
- Small footprint simplifies upgrades and saves valuable panel space
- Lightweight, compact, simple-to-maintain design supports up to four sample streams

Typical Applications

- Anion exchange monitoring in pure water treatment detects the first breakthrough at very low ppb levels of silica to trigger regeneration and ensure contaminated water can be diverted before it reaches critical areas.
- Power steam quality monitoring protects turbines from silica deposition and resulting imbalance, loss of capacity and reduced efficiency. Silica measurement and control may also be needed to meet turbine manufacturer warranty requirements.
- At larger plants, monitoring silica levels at the economizer provides a final feed-water quality check before the pre-heated water enters the steam drum.
- When treating boiler water with phosphate, monitoring ppm levels is important for maintaining appropriate concentrations to control scale and protect against caustic corrosion.

Specifications

Measurements

Silica measurement range	0.5 – 5,000 ppb
Phosphate measurement range	0.3 – 10 ppm
Silica measurement accuracy	± 5 % of reading or ± 1 ppb, whichever is greater
Phosphate measurement accuracy	± 10 % of reading or ± 0.3 ppb, whichever is greater
Resolution	4 digits with decimal, auto ranging; 0.001 ppb in lowest range
Measurement cycle time	Adjustable ≥ 10 min; 20 min typical
Reagent consumption	Approx. 500mL each per 3 months with 20 min measurement cycle time
Sample flow rate	50 – 250 mL/min
Sample temperature	5 – 60 °C (41 – 140 °F)
Sample pressure	0.3 – 7 bar (5 – 100 psig)
Zero calibration	Automatic, every measurement cycle
Span calibration	Automatic per schedule; once per month, typical
Grab sample measurement	500mL capacity

Outputs

Analog output	8 powered 0/4 – 20 mA, 22 mA alarm, 500 ohm max load, not for use with externally powered circuit
Analog output accuracy	± 0.05 mA
Analog output scaling	Linear, bi-linear, logarithmic (1,2,3,4 decades), auto ranging
Relay contacts	4-SPST mechanical rated at 250 VAC, 3 A; 4-SPST Type Reed 250 VAC or DC, 0.5 A
Digital input	Remote start/stop of measurement cycle
Communication	PROFIBUS DP

Installation/Power/Enclosure

Operator interface	TFT color touchscreen; simultaneous display of silica/phosphate concentration and measurement or auto-cal status
Process connections	Sample inlet: 6 mm or 1/4" OD tube SS compression fitting Drain hose: 19 × 25.4 mm (¾ × 1"), 2 m (6ft) length included
Power supply	100 – 240 VAC, 50 – 60 Hz, 65 W; all settings retained on power loss
Dimensions HWD	Enclosure: 543 × 396 × 300 mm (21.4" × 15.6" × 11.8")
Weight	18 kg (40 lbs)
Ambient operating temperature	10 – 50 °C (50 – 122 °F)
Humidity	10 – 90 % non-condensing
Ingress protection	IP 66/NEMA 4X (Electronics); IP 55 (Enclosure)
Ratings/approvals	CE, cULus, UKCA

Specifications subject to change.

Ordering Information

Description	Order No.
Analyzer 2850Si Silica, 1-stream	30 571 931
Analyzer 2850Si Silica, 2-stream	30 571 932
Analyzer 2850Si Silica, 4-stream	30 571 933
Analyzer 2850Si Silica, 1-stream with Phosphate	30 571 934
Analyzer 2850Si Silica, 2-stream with Phosphate	30 571 935
Analyzer 2850Si Silica, 4-stream with Phosphate	30 571 936
Analyzer 2850Si Silica, 1-stream Panel	30 571 937
Analyzer 2850Si Silica, 2-stream Panel	30 571 938
Analyzer 2850Si Silica, 4-stream Panel	30 571 939
Analyzer 2850Si Silica, 1-stream Panel with Phosphate	30 571 940
Analyzer 2850Si Silica, 2-stream Panel with Phosphate	30 571 941
Analyzer 2850Si Silica, 4-stream Panel with Phosphate	30 571 942
Silica Reagent Kit* (3 month supply of reagents and 500 mL of 250ppb silica calibration standard.)	30 571 930
Silica/Phosphate Reagent Kit* (3 month supply of reagents and 500 mL of 250 ppb silica / 1 ppm PO ₄ calibration standard.)	30 571 929

* Reagent Kit determined based on Silica only or Silica/Phosphate measurement models.



3000CS Chloride & Sulfate Analyzer

High Sensitivity, On-line Measurement



The METTLER TOLEDO Thornton 3000CS Analyzer is a reliable on-line instrument designed to directly measure chlorides and sulfates in pure water and power cycle chemistry. This analyzer enables monitoring of these highly corrosive contaminants to assist in corrosion control and minimizing damage to critical plant equipment. Early, unambiguous detection of trace levels of these contaminants is enabled with minimal operator supervision.

Features/Benefits

- Intuitive touchscreen interface: allows display of trendlines for each measurement
- Simultaneous display of ion concentrations and measurement timing: provides convenient analyzer status at a glance, saving operator time
- Analog outputs with choice of scaling: enables easy integration into data acquisition systems
- Convenient grab sample capability: allows measurement of additional samples or for QC checks
- Full enclosure: protects reagent containers and components from plant environment

Typical Applications

- Steam quality monitoring at turbine inlet to ensure chloride and sulfate levels are under acceptable limits.
- Condensate monitoring at condensate polisher, to detect breakthrough or deterioration of sulfonated cation resin.
- Boiler feedwater monitoring, to activate boiler blowdown if needed to control contaminant levels.
- Makeup water quality.

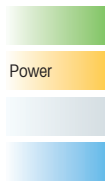

Power

Specifications

Measurements	
Range	0–300 ppb
Limit of detection	Chloride: 0.5 ppb; Sulfate: 1 ppb
Accuracy	Chloride: $\pm 5\%$ of reading ± 0.5 ppb, typical; Sulfate: $\pm 10\%$ of reading ± 1 ppb
Measurement cycle time	45 min typical, programmable between 15 minutes and 1 hour
Sample flow rate	25–50 mL/min
Sample temperature	10–45°C (50–113 °F)
Sample pressure	0.3–7 bar (5–100 psig)
Grab sample measurement	100 mL capacity
Outputs	
Analog outputs	8 powered 0/4–20 mA, 22 mA alarm, 500 ohm max load, not for use with externally powered circuit
Analog output accuracy	± 0.05 mA
Analog output scaling	Linear, bi-linear, logarithmic (1,2,3,4 decades), auto ranging
Relay contacts	Mechanical rated at 250 VAC, 3 Amps (Relay 1 NC, Relay 2 to 4 NO), 4-SPDT Type Reed 250 VAC or DC, 0.5 Amps (Relay 5 to 8)
Installation/Power/Enclosure	
Operator interface	Color touchscreen; simultaneous display of ion concentrations and analyzer status
Process connections	Sample inlet: 1/4" or 6 mm OD tube SS compression fitting Drain hose: 19 × 25.4 mm (3/4 × 1"), 2 m (6 ft) length included
Power	100–240 VAC, 50–60 Hz, 100 W typical
Dimensions HWD	927 × 508 × 305 mm (36.5" × 20.9" × 12")
Weight	44 kg (97 lbs)
Ambient operating temperature	10–35°C (50–95 °F)
Humidity	10–70 % non-condensing
Ratings/approvals	CE, cULus, UKCA

* Specifications subject to change.

Ordering Information

Description	Order No.
3000CS Analyzer	58 044 001
Required Consumable Kit	58 091 401
Includes 2-month supply of reagents, cartridge, and calibration standard solution.	
Conditioning Resin Kit	30 416 018
Replacement Resin Cartridge	30 416 019

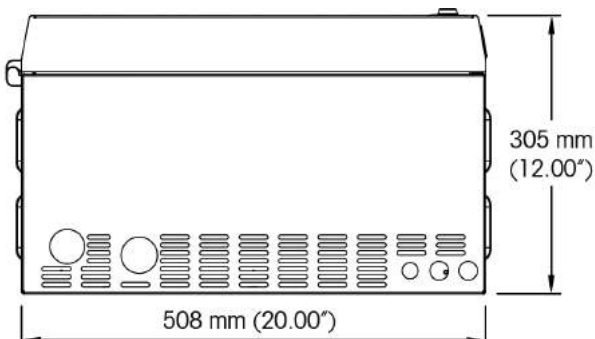

Transmitters for All Parameters Your Access to Water Analytics

Whether you require a multi-parameter, multi-channel, parameter specific or portable unit, METTLER TOLEDO's wide portfolio of globally-approved transmitters includes the right solution for you.

Constant information

Transmitters are the components that communicate to the user and translate sensor readings into displayed measurements for indication and control. METTLER TOLEDO provides tailorable transmitter solutions to meet the needs of a wide range of applications and functional requirements. Intelligent diagnostics keep users informed of sensor "health".

Single- or multi-channel?

For simpler processes where only a single parameter requires measurement, a single-channel transmitter is the obvious choice, but for processes where more than one parameter must be monitored, multi-channel, multi-parameter transmitters offer significant advantages and value. METTLER TOLEDO multi-channel transmitters combine operating flexibility with ease of use.

Communication

We offer transmitters for most common communication protocols for easy interface with your DCS or PLC. Intelligent Sensor Management (ISM) diagnostics data can also be accessed on control systems to provide an overview of the performance of all measurement systems from one point.



The way forward

Use of digital sensors is becoming increasingly common in the process industries. Many of our transmitters accept traditional analog as well as ISM digital sensors, providing a future oriented investment in your plant. Our latest transmitter developments include the M800 multi-parameter, multi-channel unit. Its large touchscreen

display and intuitive menus save operating time, while predictive maintenance ensures reliability and reduced maintenance. The M300 is flexible, price competitive and offers single and dual channel measurements with ISM or analog sensors. The M200 has been designed around one central requirement: ease-of-use. From system selection to commissioning, operation and maintenance,

all M200 system components are narrowly tailored to include only necessary functions. METTLER TOLEDO Thornton transmitters provide reliable performance for measuring conductivity, total organic carbon (TOC), pH, ORP, dissolved oxygen, dissolved ozone and flow.



	M200 (p. 226–229)	M300 Water (p. 230–233)	M400 (p. 86–89)	M800 Water (p. 234–235)
Channels	1/2	1/2	1	2/4
Plug and Measure	•	•	•	•
Dynamic Lifetime Indicator (DLI)	–	•	•	•
Adaptive Calibration Timer (ACT)	–	•	•	•
Time To Maintenance (TTM)	–	•	•	•
Calibration history	–	•	•	•
iMonitor	–	•	•	•
CIP/SIP/autoclaving counter	–	•	•	•
Power plant calc parameters	•	•	–	•
USP/EP conductivity setpoints	•	•	•	•
Di-Cap™	–	–	–	•
Communication	–	–	HART	Profibus DP, Profinet*, Ethernet/IP*
Panel cutout	½ DIN, ¼ DIN	½ DIN, ¼ DIN	½ DIN	½ DIN
Mixed-mode input	–	•	•	–
PID controller	–	•	•	•
Hold input	•	•	•	•
Analog input	–	–	**	•
Relays	2	4	4	4/8
Analog outputs	2/4	2/4	4	4/8
USB data logging	–	•	•	–
Transmitter Configuration Tool (TCT)	•	•	•	•
Approvals	cULus, CE	cULus, CE	cCSAus Cl 1 Div 2, ATEX Zone 2, CE, NEPSI	cULus, CE
Parameter compatibility (water)				
pH/ORP/pNa	•	•	•	•
Dissolved oxygen				
Amperometric sensors				
Low (High Performance)	•	•	**	•
Optical sensors				
Low (pure ODO)	–	–	**	•
TOC	–	–	–	•
Conductivity 2-e/4-e (analog)	–	•	•	–
UniCond 2-e/4-e	•	•	•	•
Dissolved ozone	•	•	**	•
Flow**	•	–	–	•
21CFR Part 11 RecordLOC	–	–	–	•

* Model dependent

** Each M800 has two pulse flow input channels. Additional flow sensors can be connected using optional pulse flow adapter. Flow is available on selective M200 models.

M200: Convenient and Reliable For Basic Water Applications



The METTLER TOLEDO M200 transmitter line provides an exceptional ease-of-use interface for digital conductivity, pH, ORP, dissolved oxygen and ozone measurement. From system selection to commissioning, operation and maintenance, all system components are designed to eliminate any unnecessary functions. Plug and Measure provides maximum compatibility and easy operation for digital sensor operation. Simply connect selected digital ISM or unique to M200 digital easySense sensors and the transmitter does the rest.

Specifications

Enclosure / Power

Operator interface	4 line backlit LCD; 5 tactile keys
Material	Polycarbonate
Weight, ¼ DIN models	0.7 kg (1.5 lb)
Weight, ½ DIN models	1 kg (2.2 lb)
UL electrical environment	Installation (overvoltage) Category II
Ratings/approvals	UL (US & Canada), CE compliant; ¼ DIN: IP 65 (front); ½ DIN: IP 65/UL 4X
EMC emissions	EN61226-1:2013 Class A
Power	Universal 100–240 VAC, 50–60 Hz or 20–30 VDC; 5 W

Outputs

Analog outputs (as specified for individual models)	Powered 0/4–20 mA, 22 mA alarm, 500Ω maximum load; not for use with externally powered circuits
Analog output accuracy	±0.05 mA
Analog output scaling	Linear, bi-linear, logarithmic (1,2,3 or 4 decades), auto ranging
Relays (as specified for individual models)	All contacts are potential free, with adjustable hysteresis and time delay SPDT, SPST NO, SPST NC: 250 VAC/30 VDC, 3 A, resistive SPST reed: 300 VDC, 0.5 A, 10 W
Flow models only	SPST reed: 300 VDC, 0.5 A, 10 W
Service interface	USB, type B connector, for remote configuration and commissioning
Discrete input (as specified individual models)	Accepts dry contact closure for remote flow totalizer reset or for remote PID control auto/manual selection

Other Highlights

- Digital easySense and ISM sensor compatibility
- Quick setup mode for fast installation
- Digital, backlit, high contrast display

Features Overview

- Multi-parameter allows up to two user-configurable channels with pre-calibrated sensors
- Selectable conductivity temperature compensation on/off and USP alarm capabilities
- Multi-level password protection against accidental changes
- Transmitter Configuration Tool (TCT) software included, for fast, simple and consistent transmitter programming via USB port

► www.mt.com/M200

Transmitter Specifications

Outputs		
pH/ORP/Cond/DO/Ozone/Temperature	Single-channel	Two-channel
Setpoints/alarms	4-high, low, outside, between, USP, EP	6-high, low, outside, between, USP or EP
Relays	2 SPDT	2 SPDT
Analog output signals	2	4
Discrete inputs	1	2
Flow	Single-channel	Four-channel
Setpoints/alarms	4-high, low, outside, or between	8-high, low, outside, or between
Relays	2 SPDT, 1 SPST NO, 1 SPST NC	2 SPDT, 1 SPST NO, 1 SPST NC
Analog output signals	2	4
Discrete inputs, for external totalizer reset	1	2

Flow Transmitter Specifications

Flow rate range	0 to 9999 GPM, L/min, m ³ /hr
Total flow range	0 to 9,999,999 Gallons, 37,850,000 Liters, 37,850 m ³
RO % recovery range	0 to 100 %
Flow velocity range	Equivalent ft/s, m/s
Frequency range	1 to 4000 Hz
Calculated parameters	Ratio, sum and difference of two flowrates (4-channel)
Resolution	4 significant digits, auto-ranged; up to 8 digits for total flow
Update rate	Display and outputs, once per 2 s
Input pulses	Low < 1.0 volt; high > 1.4 volts (36 volts max.)
Accuracy	± 0.5 Hz
Repeatability	± 0.2 Hz

Measurement Specifications

See ISM sensor pages for specifications: conductivity pages 166–167, pH/ORP pages 176–185, dissolved oxygen pages 186–191 (note optical dissolved oxygen is not compatible with M200), and dissolved ozone page 192–193.

M200 Digital easySense Measurement Specifications (only compatible with M200 transmitter models)

Selected specifications of easySense conductivity sensors				
	71	72	73	77
Type	2-electrode	2-electrode	2-electrode	4-electrode
Cell constant	0,1 cm ⁻¹	0,1 cm ⁻¹	0,1 cm ⁻¹	0.3 cm ⁻¹
Measuring range	0.01–2000 µS/cm	0.01–2000 µS/cm	0.01–2000 µS/cm	0.02–400 mS/cm
System accuracy	± 3.0 % or better	± 3.0 % or better	± 3.0 % or better	± 5.0 % or better
Temperature compensation	standard high purity, cation, ammonia, Light 84, isopropanol, glycol			
Temperature sensor	30 kOhm NTC	30 kOhm NTC	30 kOhm NTC	30 kOhm NTC
Electrode material	Titanium	Titanium	Titanium	1.4404 SS (316L)
Insertion fitting	¾" NPT	½" NPT	¾" NPT & subm.	¾" NPT
Cable length/Order number				
– 7.6 m (25 ft)	58 031 300	58 031 302	58 031 304	–
– 30.5 m (100 ft)	58 031 301	58 031 303	58 031 305	–
– K8S connector	–	–	–	52 003 810

Transmitters

Outstanding Performance, Advanced Electronics



M200 Digital easySense Measurement Specifications (only compatible with M200 transmitter models) continued

Selected specifications of easySense pH / ORP, and oxygen sensors

	31	32	33	34	41	21
Parameter	pH	pH	pH	pH	ORP	Oxygen
Measurement range	0–14	0–14	0–14	0–14	± 1500 mV	0.03 ppm – 100% saturation
Temperature	–5–80 °C (23–176 °F)	–5–80 °C (23–176 °F)	–5–80 °C (23–176 °F)	–5–80 °C (23–176 °F)	–5–80 °C (23–176 °F)	0–60 °C (32–140 °F)
Pressure resistance	0–2 barg (0–29 psig)	0–2 barg (0–29 psig)	0–2 barg (0–29 psig)	0–2 barg (0–29 psig)	0–2 barg (0–29 psig)	0.5–2 barg (7–29 psig)
Pressure resistance 0–40 °C (32–104 °F)	0–6 barg (0–87 psig)	–	–	–	0–6 barg (0–87 psig)	–
Reference system	Argenthal (Ag/AgCl)	Argenthal (Ag/AgCl)	Argenthal (Ag/AgCl)	Argenthal (Ag/AgCl)	Argenthal (Ag/AgCl)	–
Reference electrolyte	Gel	Pressurized gel	Pressurized gel	Pressurized gel	Polymer	–
Diaphragm	1 ceramic	1 ceramic	1 ceramic	1 ceramic	Open junction	–
Membrane glass	HA	HA	HF	LoT	– (Platinum ring)	–
Application	General purpose	Harsh processes	HF resistant	Low temperature	General purpose	General purpose
Plug head	K8S, Pg 13.5	K8S, Pg 13.5	K8S, Pg 13.5	K8S, Pg 13.5	K8S, Pg 13.5	K8S, Pg 13.5
Order number	52 003 771	52 003 768	52 003 770	52 003 769	52 003 772	52 206 406

Selected specifications of easy housings

	easyFit™ 21	easyFit 22	easyFlow™ 21, 22	easyFlow 23	easyDip™ 21, 22
Material	CPVC	Stainless Steel	CPVC	Polysulfone	PVC
Temperature	–5–80 °C (23–176 °F)	–5–100 °C (23–212 °F)	–5–80 °C (23–176 °F)	–5–130 °C (23–266 °F)	0–60 °C (32–140 °F)
Max pressure at	7.0 barg / 65 °C 3.5 barg / 80 °C (100 psig / 149 °F) (50 psig / 176 °F)	10 barg / 100 °C (145 psig / 212 °F)	3.5 barg / 80 °C (50 psig / 176 °F)	7.0 barg / 130 °C (100 psig / 266 °F)	ambient
Order Number	52 403 951	52 403 952	easyFlow 21: 52 403 953 easyFlow 22: 52 403 954	52 403 955	easyDip 21: 52 403 956 easyDip 22: 52 403 957
– US size					
– Metric size					

Ordering Information

Description		Order Number	Order Number
M200 Digital Transmitter	Outputs	¼ DIN	½ DIN
M200 1-channel Multi-parameter	2 Analog; 2 Relays	52 121 554	52 121 555
M200 2-channel Multi-parameter	4 Analog; 2 Relays	52 121 556	52 121 557
M200 Flow 1-channel	2 Analog; 4 Relays	30 280 748	–
M200 Flow 4-channel	4 Analog; 4 Relays	30 280 749	–

Sensor Cables for ISM

Conductivity	Order Number
0.3 m (1 ft)	58 080 270
1.5 m (5 ft)	58 080 271
3.0 m (10 ft)	58 080 272
4.5 m (15 ft)	58 080 273
7.6 m (25 ft)	58 080 274
15.2 m (50 ft)	58 080 275
30.5 m (100 ft)	58 080 276
45.7 m (150 ft)	58 080 277
61.0 m (200 ft)	58 080 278
91.4 m (300 ft)	58 080 279
pH/DO/Ozone	Order Number
1.0 m (3 ft)	59 902 167
3.0 m (10 ft)	59 902 193
5.0 m (16 ft)	59 902 213
10.0 m (33 ft)	59 902 230
Accessories	Order Number
Panel mount kit for ½ DIN models	52 500 213
Pipe mount kit for ½ DIN models	52 500 212
Adapter, VP to standard, for calibrating conductivity with VP patch cord (analog)	58 080 102
Adapter panel – M200 ¼ DIN to 200CR/2000 cutout	58 083 305

M300 Water: Versatile and User-Friendly

For a Wide Range of Applications and Industries



The multi-parameter M300 Water transmitter line for digital or analog conductivity/resistivity, pH/ORP, dissolved oxygen and ozone measurements offers exceptional measurement performance with excellent user ergonomics.

The high contrast black and white touchscreen display together with the harmonized menu structure for all parameters provides clear indication, with trending capabilities, facilitates navigation while ensuring easy, user-friendly operation. On-line diagnostics information, such as the Dynamic Lifetime Indicator, allows operators to schedule sensor maintenance or replacement. The clearly visible diagnostic information tells you when it's time to do maintenance or calibration of sensors with Intelligent Sensor Management (ISM) technology.

The integrated USB interface allows for data logging or storage of the configuration on a USB flash drive.

Specifications

Power supply	80 to 255 VAC, or 20 to 30 VDC, 10 VA
Frequency for AC	50 to 60 Hz
Current output	2 × 0/4 to 20 mA (4 × for dual channel), 22 mA alarm (according to Namur NE43)
Display	4.0" b/w touchscreen, 320 × 240 pixel
Languages	9 (English, German, French, Italian, Spanish, Portuguese, Russian, Japanese and Chinese)
Ambient temperature	-10 to 50 °C (14 to 122 °F)
Relative humidity	0 to 95% non-condensing
Rating	¼ DIN: IP65 (front) ½ DIN: IP65
PID controller	Yes
Control input (Hold)	1 or 2 (dual channel version)
Relays	2 × SPST, 2 × reed
Approvals and certificates	cULus, CE
USB interface	1 × USB Host: Data logging and configuration storage on USB flash drive 1 × USB Device: Software update interface

Other Highlights

- Mixed-mode functionality allows the connection of analog or digital ISM sensors
- Full ISM diagnostics available (for ISM sensors)

Features Overview

- 4.0" touchscreen interface/display
- Multi-parameter transmitter for conductivity/resistivity, pH/ORP, dissolved oxygen, and ozone
- Available as single-channel or dual-channel transmitters
- PID controller with pulse length, pulse frequency or analog control
- User management available

www.mt.com/M300

Measurement Specifications

Conductivity/Resistivity		Analog	ISM
Ranges	0.01 constant sensor: 0.1 constant sensor: 10 constant sensor: 4-electrode sensor:	0.002 to 200 $\mu\text{S}/\text{cm}$ 0.02 to 2,000 $\mu\text{S}/\text{cm}$ 50 to 40,000 $\mu\text{S}/\text{cm}$ 0.01 to 650 mS/cm	0.002 to 500 $\mu\text{S}/\text{cm}$ 0.02 to 50,000 $\mu\text{S}/\text{cm}^*$ 0.01 to 1,000 mS/cm
Accuracy	$\pm 0.5\%$ of reading or 0.5Ω , whichever is greater (analog only)		
Concentration ranges of HCl, NaOH, H ₂ SO ₄	0–20 %, 0–15 %, 0–20 %		
TDS ranges (CaCO ₃ and NaCl)	Cover equivalent conductivity ranges		
Calculated parameters (2-channel)	% Rejection, power plant calculations of pH based on specific and cation conductivity, and CO ₂ based on cation and degassed conductivity		
Temperature compensation	Selectable as: Std (standard high purity Thornton/Light), Light 84, Std referenced to 75 °C, linear %/°C, 50 % glycol, 100 % glycol, cation, ammonia, isopropyl alcohol, none		
pH			
pH, ORP ranges	–1.00 to 15.00 pH, –1500 to 1500 mV		
Temperature range	–30 to 100 °C (–22 to 212 °F)		
Accuracy	± 0.03 pH, ± 2 mV		
Temperature compensation	Automatic/manual for electrode output, plus adjustable solution temperature coefficient for solution ionization effects		
Calibration	1- or 2-point, with auto buffer recognition		
Diagnosics	Selectable continuous checking of membrane resistance and reference diaphragm/junction resistance (with solution ground sensors)		
Dissolved Oxygen			
Ranges	0–20,000 ppb; 0–20 ppm, 0–200 % saturation; resolution 0.1 ppb		
Temperature compensation	Automatic, for membrane permeability and oxygen solubility		
Accuracy	$\pm 1\%$ of reading or ± 1 ppb, system accuracy		
Dissolved Ozone			
Ranges	0–5,000 ppb, 0–5 ppm; resolution 0.1 ppb		
Temperature compensation	Automatic, for membrane permeability and ozone solubility		
Accuracy	$\pm 2\%$ of reading or ± 3 ppb, system accuracy		
Temperature			
Range	–40 to 200 °C (–40 to 392 °F); resolution 0.1 °		
Accuracy	± 0.25 °C (± 0.45 °F)		
Resolution	0.01 °C for conductivity; 0.1 °C for all other parameters		
PID Control			
Display	Auto/manual status and %–output on bottom line of display		
Settings	Auto/manual, setpoint, deadband, non-linear corner points, control limits, proportional gain, integral reset time (min), derivative rate time (min)		
Manual station	Controlled by up/down arrow keys in manual mode; remote auto/manual selection by discrete input		
Control output types	One or two analog signals, relays-pulse frequency, or relays-pulse length		

* stainless steel sensors 0.02 to 3,000 $\mu\text{S}/\text{cm}$

Transmitters

Outstanding Performance, Advanced Electronics

Transmitters

Measurement Specifications (cont.)

Outputs		
pH/ORP/Cond/DO/Ozone/Temperature	Single-channel	Two-channel
Setpoints/alarms	4-high, low, outside, between, USP, EP	6-high, low, outside, between, USP or EP
Relays	1 SPST NO, 1 SPST NC, 2 SPST reed	1 SPST NO, 1 SPST NC, 2 SPST reed
Analog output signals	2	4
Discrete inputs	1	2

Ordering Information

Description	Order Number
M300 Water 1-channel, Multi-parameter, ¼ DIN	30 280 776
M300 Water 1-channel, Multi-parameter, ½ DIN	30 280 777
M300 Water 2-channel, Multi-parameter, ¼ DIN	30 280 778
M300 Water 2-channel, Multi-parameter, ½ DIN	30 280 779
M300 Water 2-channel, Cond/Res Analog, ¼ DIN	30 280 774
M300 Water 2-channel, Cond/Res Analog, ½ DIN	30 280 775

Accessories

Installation accessories for ½ DIN version	Order Number
Pipe mount kit for ½ DIN	30 300 480
Panel mount kit for ½ DIN	30 300 481
Wall mounting kit for ½ DIN	30 300 482
Protective hood	30 073 328

Ordering Information

Sensor Cables for M300 (analog)

Conductivity ^a	Order Number	
Connector	Standard	VarioPin (VP) ^b
0.3 m (1 ft)	58 080 250	–
1.5 m (5 ft)	58 080 251	58 080 201
3.0 m (10 ft)	58 080 252	58 080 202
4.5 m (15 ft)	58 080 253	58 080 203
7.6 m (25 ft)	58 080 254	58 080 204
15.2 m (50 ft)	58 080 255	58 080 205
23.0 m (75 ft)	–	58 080 206
30.5 m (100 ft)	58 080 256	58 080 207
46.0 m (150 ft)	58 080 257	58 080 208
61.0 m (200 ft)	58 080 258	–

ORP

1.0 m (3 ft)	59 902 245
3.0 m (10 ft)	59 902 268
5.0 m (16 ft)	59 902 292
10.0 m (33 ft)	59 902 318

^a 4-E sensors limited to 15.2 m (50 ft), ^b For VP Conductivity sensors only

pH/DO/Ozone	Order Number
-------------	--------------

VarioPin (VP) Cables

– for Use At Standard Temperatures –30 to 80 °C / –22 to 176 °F

1.0 m (3 ft)	52 300 107
3.0 m (10 ft)	52 300 108
5.0 m (16 ft)	52 300 109
10.0 m (33 ft)	52 300 110
15.0 m (49 ft)	52 300 144
20.0 m (65 ft)	52 300 141

Sensor Cables for M300 ISM

Conductivity	Order Number
1.5 m (5 ft)	58 080 271
3.0 m (10 ft)	58 080 272
4.5 m (15 ft)	58 080 273
7.6 m (25 ft)	58 080 274
15.2 m (50 ft)	58 080 275
30.5 m (100 ft)	58 080 276
45.7 m (150 ft)	58 080 277
61.0 m (200 ft)	58 080 278
91.4 m (300 ft)	58 080 279

pH/DO/Ozone	Order Number
-------------	--------------

1.0 m (3 ft)	59 902 167
3.0 m (10 ft)	59 902 193
5.0 m (16 ft)	59 902 213
10.0 m (33 ft)	59 902 230

M800 Multi-Parameter, Multi-Channel Transmitter

Touch the Future



Features Overview

- Color touchscreen
- Intuitive operation
- Premium ISM functionality
- Multi-parameter measurement
- 2-channel/4-channel versions
- iMonitor predictive diagnostics
- User management and logbook
- Trend display
- Data Integrity option

Other Highlights

- 8 current outputs, 8 output relays
- Traffic light coded sensor status
- 2 PID process controller
- Ethernet/IP model
- PROFIBUS model
- PROFIBUS-DP model
- IP 66 rated, cULus Type 4X

The M800 transmitter series features premium Intelligent Sensor Management (ISM) technology measuring conductivity/resistivity, TOC, pH/ORP, optical and amperometric, dissolved oxygen, dissolved ozone. The multi-parameter transmitter accepts any compatible combination of ISM sensors. Up to four channels of process measurement plus two pulse flow measurements provides immediate Plug and Measure installation and operation, predictive sensor maintenance and dynamic lifetime status. The color touchscreen ensures intuitive operation, with user selectable control and alarm management. One model available with PROFIBUS-DP digital communications. ALCOA-compliant data integrity option available (M800 Water 2-channel RecordLOC).

Specifications

Performance

Measurement parameters	Conductivity/resistivity, TOC, pH/ORP, dissolved oxygen, ozone, temperature and flow
ISM	Advanced diagnostics (Dynamic Lifetime Indicator, Adaptive Calibration Timer, CIP/SIP counter etc.) iMonitor

Conductivity/Resistivity

Conductivity ranges (C = cell constant)	2-electrode sensor: C = 0.1: 0.01 to 50,000 µS/cm (20 Ω × cm to 50 MΩ × cm) C = 0.1 sanitary: 0.01 to 3,000 µS/cm (333 Ω × cm to 50 MΩ × cm) C = 0.01: 0.001 to 500 µS/cm (2,000 Ω × cm to 500 MΩ × cm)
	4-electrode sensor: 0.01 to 1,000 mS/cm (1.0 Ω × cm to 0.1 MΩ × cm)

Temperature measuring range	–40 to 200 °C (–40 to 392 °F)
Temperature compensation	Auto/selectable as: Std. (standard high purity water Thornton/Light), Light 84, Std. pure water referenced to 75 °C, linear %/°C (adjustable), 50 % glycol, 100 % glycol, cation, ammonia, isopropyl alcohol, none

TOC

Measurement range	0.05–2000 ppbC (µgC/L)
-------------------	------------------------

pH

pH range	–1 to 15
ORP input range	–1500 to 1500 mV
pH resolution	Auto/0.001/0.01/0.1/1 (can be selected)
Temperature measuring range	–30 to 150 °C (–22 to 302 °F)
Temperature compensation	Auto/manual/STC

Oxygen

Range (amperometric)	0 to 10,000 ppb (µg/L)
Range (optical)	0 to 5,000 ppb (µg/L)
Oxygen resolution	Auto/0.001/0.01/0.1/1 (can be selected)
Temperature compensation	Auto

Ozone

Operating range	0–5,000 ppb (µg/L); 0–5.0 ppm (mg/L) short term; 0–500 ppb (µg/L); 0–0.5 ppm (mg/L) continuous
-----------------	---

► www.mt.com/M800

General Specifications

Power supply	100 to 240VAC, or 20 to 30VDC, 12 VA
AC frequency	50 to 60Hz
Current (analog) outputs	8 × 0/4 to 20 mA, 22 mA alarm
Bus communications	Ethernet/IP, PROFINET, PROFIBUS-DP
User interface	Color touchscreen 5.7", Resolution 320 × 240 px, 256 colors
Languages	10 (English, German, French, Italian, Spanish, Portuguese, Russian, Japanese, Korean and Chinese)
Ambient temperature	–20 to 50 °C (–4 to 122 °F)
Relative humidity	0 to 95 %, non-condensing
Rating	IP 66 (when back cover is attached), cULus Type 4X
PID process controller	2
Hold input	Yes
Control input	Yes
Alarm contact	Yes (alarm delay 0 to 999 s)
Relays	Mechanical rated at 250VAC, 3 Amps (Relay 1 NC, Relay 2 to 4 NO); 4 – SPDT Type Reed 250 VAC or DC, 0.5Amps (Relay 5 to 8)
Setpoints	High, low, between, outside, USP, EP

Ordering Information

Transmitters	Order Number
M800 Water 2-channel + 2 flow	58 000 802
M800 PROFIBUS-DP Water 2-channel + 2 flow	58 000 806
M800 Water 4-channel + 2 flow	58 000 804
M800 Water 2-channel PROFINET + 2 flow	30 530 026
M800 Water 2-channel Ethernet/IP + 2 flow	30 530 028
M800 Water 4-channel Ethernet/IP + 2 flow	30 530 029
M800 Water 2-channel RecordLoc	30 656 182
Installation Accessories	
Pipe mount kit	52 500 212
Panel mounting kit 1/2DIN M300G2/M400G2	30 300 481
Panel mounting kit 1/2DING1/M400 2w/M800	52 500 213
Wall mounting kit for 1/2DIN	30 300 482
Protective hood	30 073 328

ISM Sensor Cables

Conductivity/TOC	Order Number	pH/DO*/O ₃	Order Number
1.5 m (5ft)	58 080 271	1.0m (3ft)	59 902 167
3.0m (10ft)	58 080 272	3.0m (10ft)	59 902 193
4.5m (15ft)	58 080 273	5.0m (16ft)	59 902 213
7.6m (25ft)	58 080 274	10.0m (33ft)	59 902 230
15.2m (50ft)	58 080 275	20.0m (66ft)	52 300 204
30.5m (100ft)	58 080 276	30.0m (98ft)	52 300 393
45.7m (150ft)	58 080 277	50.0m (164ft)	52 300 394
61.0m (200ft)	58 080 278	80.0m (264ft)	52 300 395
91.4m (300ft)	58 080 279		

* Except optical DO

Optical DO

Sensor Cables	Order Number
2m (6.6ft)	52 300 379
5m (16.4ft)	52 300 380
10m (32.8ft)	52 300 381
15m (49.2ft)	52 206 422

Trademark Information

METTLER TOLEDO, the METTLER TOLEDO logo, INGOLD and THORNTON are trademarks of the METTLER TOLEDO Group.

ISM, iSense, iMonitor, InPro, InDip, InTrac, InTap, InFlow, iLink, GPro, Pro2Go, OptoCap, MembraCap, CalBox, CaliCap, UniCond, 7000RMS, pHure Sensor, pureO₃, MaxCert, WideRange, Tri-Lock, RecordLoc, EasyClean, easySense, easyFit, easyFlow, easyDip, Argenthal, FriscoLyt, Viscolyt and Xerolyt are trademarks of the METTLER TOLEDO Group.

Viton and Kalrez are registered trademarks of DuPont Performance Elastomers LLC.

All other trademarks are the property of their respective holders.

**Mettler-Toledo Ingold & Thornton
National Sales Managers**

Director of Sales

Dave Ferragamo
Cell: 339-223-8501
Email: Dave.Ferragamo@mt.com

Sales Manager Hygienic-US

Doug Brees
Cell: 949-246-9627
Email: Doug.Brees@mt.com

Sales Manager Process Industries-US

Larry Hale
Cell: 912-655-2010
Email: Larry.Hale@mt.com

**Mettler-Toledo Ingold & Thornton
Hygienic Industries Regional Sales Managers**

Central Regional Sales Manager

John Groetsch
Cell: 630-730-6818
Email: John.Groetsch@mt.com

Northeast Regional Sales Manager

Ben Paris
Cell: 215-534-5613
Email: Ben.Paris@mt.com

Northeast Regional Sales Manager

Erin White
Cell: 978-578-0159
Email: Erin.White@mt.com

Gulf Southeast Regional Sales Manager

Harvey Klaer
Cell: 404-290-7063
Email: Harvey.Klaer@mt.com

Midsouth Regional Sales Manager

Kelly Sweazea
Cell: 919-805-8984
Email: Kelly.Sweazea@mt.com

Midatlantic Regional Sales Manager

Joseph Colamarino
Cell: 717-309-9163
Email: Joseph.Colamarino@mt.com

**Mettler-Toledo Ingold & Thornton
Process Industries Regional Sales Managers**

Southeast Regional Sales Manager

David Mincer
Cell: 337-281-2694
Email: David.Mincer@mt.com

West Coast Regional Sales Manager

Derick Krutsinger
Cell: 360-335-5488
Email: Derick.Krutsinger@mt.com

Gulf Coast Regional Sales Manager

Jason Harrington
Cell: 512-638-3851
Email: Jason.Harrington@mt.com

East Regional Sales Manager

Jay Mershon
Cell: 215-478-4074
Email: Jay.Mershon@mt.com

Central Regional Sales Manager

Sandy Gates
Cell: 859-421-1685
Email: Sandy.Gates@mt.com

**Mettler-Toledo Ingold & Thornton
Regional Sales Managers All Industries**

Midwest Regional Sales Manager

Mike McFadden
Cell: 612-655-7032
Email: Mike.McFadden@mt.com

Rocky Mountain Regional Sales Manager

Kim Johnson
Cell: 303-335-5653
Email: Kim.Johnson@mt.com

**Mettler-Toledo Ingold & Thornton
Representatives for the USA & Puerto Rico**

ACI Controls Inc.

295 Main Street, W. Seneca, NY 14224
Tel: 716-675-9450
www.aci-controls.com

Alliance Technical Sales

312 Park Avenue, Unit 145, Clarendon Hills, IL 60514
Tel: 630-321-9646
www.alliancets.com

Applied Controls

10325 East 58th Street South, Tulsa, OK 74146
Tel: 918-259-0020
www.appliedcontrolscorp.com

Automated Engineering Services

3520 Sagate Way, Ste 115, Oceanside, CA 92056
Tel: 760-847-4164
www.thinkaes.com

Entech

1219 Winter Lane, Schwenksville, PA 19473
Tel: 610-287-0920
www.entechcompany.com

Escotech Inc.

2005 Italia Street, San Juan, PR 00911
Tel: 787-728-0552
www.escotechinc.com

FLW Southeast

4451 Canton Road, Marietta, GA 30066
Tel: 770-424-1731
www.flwse.com

Heartland Controls

19027 Jodi Road, Unit F, Mokena, IL 60448
Tel: 708-478-5210
www.heartland-controls.com

Jasper Engineering

700 Hamel Road, Medina, MN 55340
Tel: 952-938-6504
www.jaspereng.com

Liquidyne Process Technologies

11919 I-70 Frontage Road, Unit 106, Wheat Ridge, CO 80033
Tel: 303-205-9050
www.liquidyneusa.com

**Mettler-Toledo Ingold & Thornton
Representatives for the USA & Puerto Rico
Cont.**

Moody Price LLC

18320 Petroleum Drive, Baton Rouge, LA 70809
Tel: 225-767-7755
www.moodyprice.com

Moody Price Texas

4533 Brittmoore Road, Houston, TX 77041
Tel: 713-983-8032
www.moodyprice.com

Neponset Controls

71 Elm Street, Unit 1, Foxboro, MA 02035
Tel: 508-543-4801
www.neponsetcontrols.com

Northeast Water Services

67 Green Street, Foxboro, MA 02035
Tel: 508-203-2440
www.ne-water.com

Optimal Biotech Group

131 Industrial Road, Unit 7, Belmont, CA 94002
Tel: 650-376-3837
www.optimalbiotech.com

Power Process Engineering

24300 Catherine Industrial Drive, Ste 403, Novi, MI 48375
Tel: 248-473-8450
www.powerprocessengineering.com

PROAnalytics

333 US Hwy 46, Ste 201, Fairfield, NJ 07004
Tel: 973-241-1314
www.pro-analytics.net

Process Controls

6519 Ferguson Street, Indianapolis, IN 46220
Tel: 317-259-1316
www.processcontrolscorp.com

Process Technology Inc.

4084 S 300 W, Salt Lake City, UT 84107
Tel: 801-264-1114
www.process-tech.com

Relevant Solutions

2500 Pegasus Drive, Bakersfield, CA 93308
Tel: 661-493-2300
www.relevantolutions.com

Unit Process Co

834 80th Street SW, Ste 300, Everett, WA 98203
Tel: 281-295-8850
www.unitprocess.com

WGS Equipment & Controls

3060 Plaza Drive, Ste 110, Garnet Valley, PA 19061
Tel: 610-459-8800
www.wgsequipment.com

For the most up-to-date addresses
of METTLER TOLEDO globally, visit
www.mt.com/PRO-MOs

The Information You Want is at www.mt.com/pro

The METTLER TOLEDO Process Analytics website contains a vast amount of up-to-date information on all our products and services. Content is localized for your country and tailored to suit your selections. Simple layout allows you to quickly find the information and features you are looking for.



Visit our website for fast and competent information.

- Learn about our most recent product developments
- Register for free webinars
- Request further information on products and services
- Obtain a quote quickly and easily
- Download our latest white papers
- Read case studies relevant to your industry
- Access buffer and electrolyte solution certificates

www.mt.com/pro

Visit for more information

METTLER TOLEDO Group

Process Analytics

Local contact: www.mt.com/pro-MOs

Subject to technical changes

© 01/2022 METTLER TOLEDO

All rights reserved. PA0001en

Printed in U.S. 52 900 315