

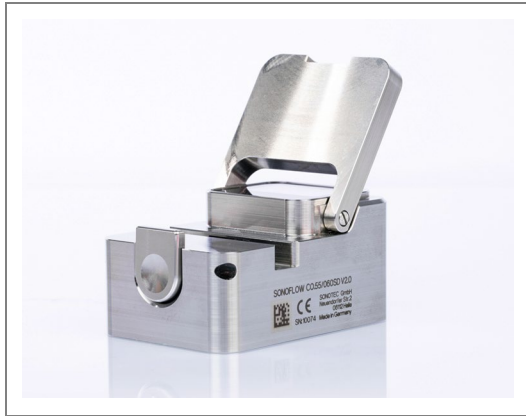

The sensor series **SONOFLOW CO.55/xxxSD(H) V2.0** with stainless steel housing and display – designed as clamp-on-sensors – detect the flow rate of liquids in plastic tubes of different diameters or materials within a few milliseconds.



For applications on tubes with large outer diameters the sensors **SONOFLOW CO.55/xxxSD(H) V2.0** are equipped with a handle for an optimized handling for tube insertion.

The sensors have no contact to the medium or product. With stainless steel housing they are suitable for applications in fields with strict hygienic standards. Due to the current, frequency and switching outputs industrial dosing applications can be supported. The RS-485 interface (SONOTEC protocol; Modbus® via software settings) allows bus operation of up to 12 sensors in rough industrial environments.

The **SONOFLOW CO.55/xxxSD(H) V2.0** sensors with complete built-in electronics can be installed in machines or apparatuses. The display shows the current flow rate and the measuring state.

In addition to our standard sensors, we also manufacture customer-specific solutions regarding housing materials, colors, mechanical dimensions, customized output specifications and parameter settings.

Overview sensors

Specification SONOFLOW	Order-No.	Max. flow range	Measuring channel (CH = CW)	Dimensions (L × W × H)	Weight
CO.55/035SD V2.0	200 08 0036	3 000 ml/min	□ 3.5 mm	44 × 64 × 31 mm	380 g
CO.55/060SD V2.0	200 08 0032	6 000 ml/min	□ 6.0 mm	44 × 64 × 33 mm	420 g
CO.55/080SD V2.0	200 08 0057	8 000 ml/min	□ 8.0 mm	44 × 64 × 35 mm	430 g
CO.55/100SD V2.0	200 08 0030	10 000 ml/min	□ 10.0 mm	44 × 64 × 38 mm	480 g
CO.55/120SD V2.0	200 08 0074	12 000 ml/min	□ 12.0 mm	44 × 64 × 40 mm	500 g
CO.55/140SD V2.0	200 08 0058	14 000 ml/min	□ 14.0 mm	44 × 64 × 42 mm	520 g
CO.55/160SD V2.0	200 08 0031	18 000 ml/min	□ 16.0 mm	44 × 64 × 45 mm	540 g

Specification SONOFLOW (with Handle)	Order-No.	Max. flow range	Measuring channel (CH × CW)	Dimensions L × W × H [Height without handle]	Weight
CO.55/190SDH V2.0	200 08 0070	40 000 ml/min	□ 19.0 mm	50 × 88 × 64 [43] mm	800 g
CO.55/230SDH V2.0	200 08 0048	50 000 ml/min	□ 23.0 mm	50 × 88 × 66 [45] mm	800 g
CO.55/260SDH V2.0	200 08 0042	70 000 ml/min	□ 26.0 mm	50 × 88 × 68 [47] mm	800 g
CO.55/300SDH V2.0	200 08 0075	100 000 ml/min	□ 30.0 mm	50 × 88 × 73 [52] mm	800 g
CO.55/340SDH V2.0	200 08 0051	140 000 ml/min	30.0 × 34.0 mm	50 × 88 × 74 [53] mm	800 g

Tubing properties

Material: PVC, Silicone, PTFE, PFA, FEP, TPE, Tygon, PE, etc.
Outer diameter: ≈ 4 mm ... 35 mm

	<p>Note</p> <p>The following listed tubes are examples for frequently used tubes and the given OD and ID are guiding values. The sensors are also applicable for further tubing diameters, up to 2". The selection of the right sensor depends on tubing dimensions as well as on tubing properties. If possible, provide us with a tubing sample (minimum length 50 cm).</p>
---	--

Other materials and diameters upon request. Contact our service.

Specification SONOFLOW	Tubing OD		Tubing ID		Wall thickness		Tubing
	[mm]	[inch]	[mm]	[inch]	[mm]	[inch]	
CO.55/035SD V2.0	4.0 mm		3.0 mm		0.5 mm		PVC, Deutsch & Neumann 3500304
	3.96 mm	5/32" 0.1563"	0.79 mm	1/32" 0.031"	1.6 mm	1/16" 0.0625"	Platinum-Cured Silicone, Cole-Parmer® L/S 13, Masterflex®
CO.55/060SD V2.0	7.0 mm		5.0 mm		1.0 mm		PVC, ESSKA, 702101051099
	6.35 mm	1/4" 0.25"	3.18 mm	1/8" 0.125"	1.6 mm	1/16" 0.0625"	Platinum-Cured Silicone, Cole-Parmer® L/S 16, Masterflex®
CO.55/080SD V2.0	9.0 mm		6.0 mm		1.5 mm		PVC, ESSKA, 702101061599
	9.53 mm	3/8" 0.375"	6.35 mm	1/4" 0.25"	1.6 mm	1/16" 0.0625"	Platinum-Cured Silicone, Cole-Parmer® L/S 17, Masterflex®
CO.55/100SD V2.0	12.0 mm		9.0 mm		1.5 mm		PVC, ESSKA, 702101091550
	11.13 mm	7/16" 0.438"	6.35 mm	1/4" 0.25"	2.39 mm	3/32" 0.0938"	Platinum-Cured Silicone, Cole-Parmer® L/S 24, Masterflex®
CO.55/120SD V2.0	14.0 mm		10.0 mm		2 mm		PVC, ESSKA, 702101102050
	14.29 mm	9/16" 0.563"	9.53 mm	3/8" 0.375"	2.39 mm	3/32" 0.0938"	Platinum-Cured Silicone, Cole-Parmer® L/S 36, Masterflex®
CO.55/140SD V2.0	16.0 mm		12.0 mm		2 mm		PVC, ESSKA, 702101122050
	15.88 mm	5/8" 0.625"	9.53 mm	3/8" 0.375"	3.18 mm	1/8" 0.125"	Platinum-Cured Silicone, Cole-Parmer® I/P 73, Masterflex®
CO.55/160SD V2.0	19.0 mm		14.0 mm		2.5 mm		PVC, ESSKA, 702101142550
	19.05 mm	3/4" 0.75"	12.7 mm	1/2" 0.5"	3.18 mm	1/8" 0.125"	Platinum-Cured Silicone, Cole-Parmer® I/P 82, Masterflex®
CO.55/190SDH V2.0	22.0 mm		16.0 mm		3 mm		PVC, ESSKA, 702101163050
	22.23 mm	7/8" 0.875"	15.88 mm	5/8" 0.625"	3.18 mm	1/8" 0.125"	Platinum-Cured Silicone, Saint-Gobain, Sani-Tech® STHT®-C-625-4
CO.55/230SDH V2.0	25.4 mm		15.88 mm		4.76 mm		Platinum-Cured Silicone, Saint-Gobain, Sani-Tech® STHT®-C-625-5
CO.55/260SDH V2.0	28.56 mm		19.05 mm		4.76 mm		Platinum-Cured Silicone, Saint-Gobain, Sani-Tech® STHT®-C-750-5
CO.55/300SDH V2.0	31.75 mm		19.05 mm		6.35 mm		Platinum-Cured Silicone, Cole-Parmer® I/P 91, Masterflex®
CO.55/340SDH V2.0	34.93 mm		25.4 mm		4.76 mm		Platinum-Cured Silicone, Saint-Gobain, Sani-Tech® STHT®-C-1000-5

Manufacturers:

PVC Tubing: Deutsch & Neumann GmbH, 10585 Berlin (Germany); ESSKA.de GmbH, 20537 Hamburg (Germany)
 Silicone Tubing: Cole-Parmer®, Vernon Hills, IL 60061 United States; Saint-Gobain Performance Plastics, Solon, OH 44139

Calibration and conditions of use

Calibration	<p>Sensors are factory calibrated under the following conditions:</p> <ul style="list-style-type: none">▪ Tubing as listed and highlighted in table 'Tubing properties'▪ Water at 23 °C ± 2 °C▪ Warm up: at least 30 min (to compensate thermal effects)▪ Zero calibration just before measurement procedure▪ Normal pressure <p>Calibration to customer tubing, fluid, flow range, temperature, etc. on request.</p>
Media	Water or other acoustically transparent liquids
Conditions of use	<p>⚠ CAUTION:</p> <p>The sensors need to be adjusted individually to special operating conditions in case of operation with tubing not listed in the table 'Tubing properties', because the accuracy of flow measurement can be affected.</p> <p>Contact our service for details!</p> <hr/> <p>⚠ NOTE:</p> <p>Generally, the sensors are able to measure liquids in an extended operating temperature range of +1 to +50 °C, but with limited accuracy only.</p>

Accuracy depends on tubing, temperature, fluid properties and other conditions. Absolute accuracy is influenced by zero stability, resolution and zero offset effects. For details see next chapter.

Accuracy

Specification SONOFLOW	Upper range value	Accuracy for water: adjusted at 23 °C ± 2 K and 1 bar on specified tube (listed)	
CO.55/035SD V2.0	3 000 ml/min	0 ... 300 ml/min: ± 6 ml/min	300 ... 3 000 ml/min: ± 2 %*
CO.55/060SD V2.0	6 000 ml/min	0 ... 600 ml/min: ± 12 ml/min	600 ... 6 000 ml/min: ± 2 %*
CO.55/080SD V2.0	8 000 ml/min	0 ... 800 ml/min: ± 16 ml/min	800 ... 8 000 ml/min: ± 2 %*
CO.55/100SD V2.0	10 000 ml/min	0 ... 1 000 ml/min: ± 20 ml/min	1 000 ... 10 000 ml/min: ± 2 %*
CO.55/120SD V2.0	12 000 ml/min	0 ... 1 200 ml/min: ± 24 ml/min	1 200 ... 12 000 ml/min: ± 2 %*
CO.55/140SD V2.0	14 000 ml/min	0 ... 1 400 ml/min: ± 28 ml/min	1 400 ... 14 000 ml/min: ± 2 %*
CO.55/160SD V2.0	18 000 ml/min	0 ... 1 800 ml/min: ± 36 ml/min	1 800 ... 18 000 ml/min: ± 2 %*
CO.55/190SDH V2.0	40 000 ml/min	0 ... 4 000 ml/min: ± 80 ml/min	4 000 ... 40 000 ml/min: ± 2 %*
CO.55/230SDH V2.0	50 000 ml/min	0 ... 5 000 ml/min: ± 100 ml/min	5 000 ... 50 000 ml/min: ± 2 %*
CO.55/260SDH V2.0	70 000 ml/min	0 ... 7 000 ml/min: ± 140 ml/min	7 000 ... 70 000 ml/min: ± 2 %*
CO.55/300SDH V2.0	100 000 ml/min	0 ... 10 000 ml/min: ± 200 ml/min	10 000 ... 100 000 ml/min: ± 2 %*
CO.55/340SDH V2.0	140 000 ml/min	0 ... 14 000 ml/min: ± 280 ml/min	14 000 ... 140 000 ml/min: ± 2 %*

* of reading

Technical data

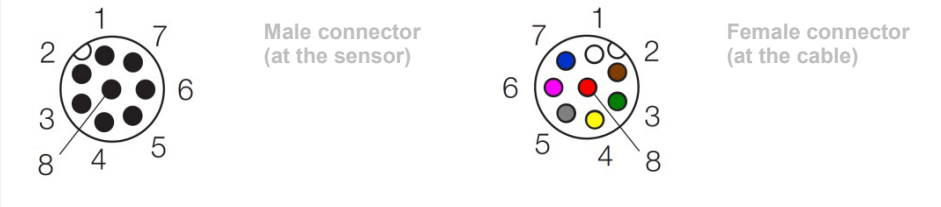
SONOFLOW CO.55/xxxSD(H) V2.0			
Flow Sensor for liquids			
Measuring method	Ultrasound, two sections of measurements, dry coupling, no couplant required		
Mounting	Fixed installation: 4 fixing holes	CO.55/xxxSD V2.0 CO.55/xxxSDH V2.0	M4, 8 mm deep M5, 8 mm deep
Sensor materials	Measuring channel: PMMA black, Display protection: PMMA transparent, Housing: stainless steel 1.4404		
Operating voltage	12 ... 30 VDC, maximum ripple 10 %, protection against reverse-polarity (external fuse, if required: min. 200 mA)		
Current consumption	Maximum 50 mA (with open current, frequency and switching output, depending on supply voltage)		
Electrical connection	8-pin M12 Connector, DIN EN 61076-2-101:2012		
Shielding	Required: via cable / housing (mounting screws)		
Electrical connection	M12 connecting cable		
			
Assignment	Pin	Color	Connection
	1	White	Ground
	2	Brown	Operating voltage +12 ... 30 VDC
	3	Green	Current output (0/4 ... 20 mA)
	4	Yellow	RS-485 B
	5	Grey	RS-485 A
	6	Pink	Frequency output 0 ... 20 kHz
	7	Blue	Switching output: PNP / NPN / Push-Pull
	8	Red	Digital input
Interfaces	<ul style="list-style-type: none"> • Current output for flow rate: 0/4 ... 20 mA • Frequency output for flow rate: 0 ... 20 kHz, 5 V digital • RS-485 interface: bus-capable (SONOTEC protocol, optional Modbus®) • Switching output: configurable as PNP / NPN / Push-Pull, 0 ... 30 V • Digital input 		

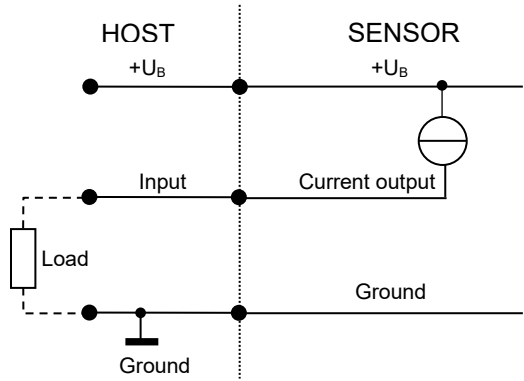
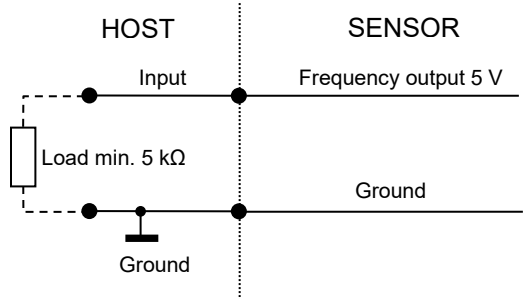
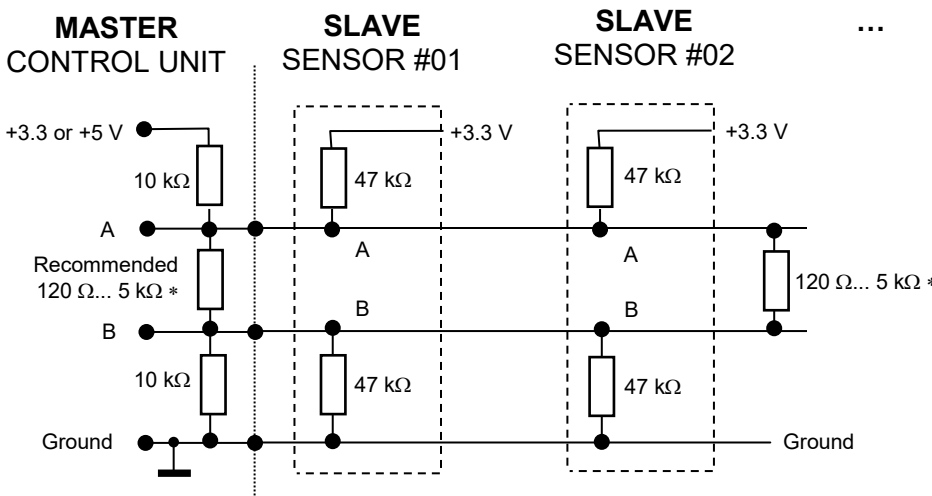
<p>Current output for flow rate</p>	<p>⚠ NOTE: Load to GND. The max. load depends on the operating voltage: 12 V → 250 Ω, 15 V → 500 Ω, 24 V → 1 kΩ, 30 V → 1.2 kΩ</p> 
<p>Frequency output for flow rate</p>	
<p>RS-485 interface</p>	<p>SONOTEC protocol: Half-duplex operation / 115.200 baud / no parity / 1 stop bit / no handshaking (Modbus® via software settings)</p> <p>⚠ NOTE: Please find the description of the serial protocol for details (upon request).</p> <p>Recommended electrical connection of the RS-485 interface</p> <p>⚠ CAUTION! If the interface is not used, it does not necessarily has to be connected; the two pins A and B can remain open.</p>  <p>* According to bus standard: depending on number of sensors and cable length</p>

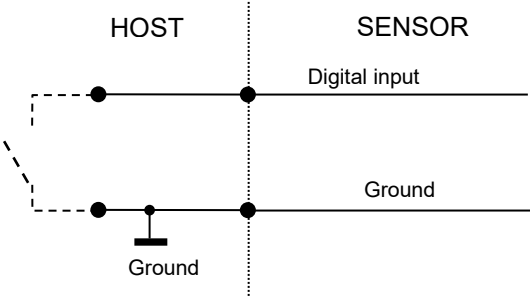
RS-485 bus operation	<p>The sensor supports bus operation with max. 12 subscribers. The default address is #01.</p> <p>⚠ NOTE: The address can be changed by software settings (see opt. accessories). Permitted are addresses from #01 ... #12. → Menu: Identification RS-485 address</p>
Switching output	<p>Freely configurable: e.g. adapting batch process or threshold switch of flow, Maximum 100 mA</p>
Digital input	<p>Freely configurable: for example for zero point calibration of flow or start dosing processes</p> <p>Voltage resistant up to 30 V</p> 
Ambient / Media temperature	<p>0 ... 60 °C, other temperatures available on request</p>
Storage temperature	<p>-20 ... +70 °C</p>
Degree of protection	<p>IP65</p>
Directives and standards	<ul style="list-style-type: none"> • EMC 2014/30/EU • RoHS 2011/65/EU, exception: III 7cl/ IV 15; RoHS 2015/863 • Acoustic emission: IEC 61157
Maintenance	<p>Maintenance-free</p>
Scope of supply	<ul style="list-style-type: none"> • SONOFLOW CO.55/xxxSD(H) V2.0 according to specification • User documentation

Optional accessories	<ul style="list-style-type: none"> • 8-pin M12 sensor cable, length 2 m / 5 m / 10 m • Calibration protocol
	<p>C³ Software for testing parameter settings, to adjust sensors for a specific application and for recording measurements consisting of</p> <ul style="list-style-type: none"> • USB Data Converter, type 013 for the connection to a computer • USB cable, type A-B, length 2 m • 8-pole M12 connecting cable, length 2 m • Switching power supply (12 VDC) • USB flash drive with C³ Software and driver for Windows
	<p>SONOFLOW RD.10 Remote Display including connecting cable for</p> <ul style="list-style-type: none"> • Monitoring sensor performance (display e.g. current flow rate, volume or measuring state) • Zero calibration • Manual volume reset
	<p>EtherNet/IP Gateway programmed for SONOTEC</p> <ul style="list-style-type: none"> • Serial communication with an EtherNet/IP-based system (e.g. PLC) • Support of up to 12 sensors • Pre-configured parameters and commands (library with Modbus registers for time-saving installation)
	<p>Portable USB Data Converter Type 023 for</p> <ul style="list-style-type: none"> • Mobile operation of sensors via a standard USB power socket or power bank • Triggering of functions stored for the digital sensor input ('push button switch')

Display



Start screen:

- displayed for 5 seconds
- shows all information about the identity of sensor



Measuring screen:

(Indication of units adaptable by software settings, see optional accessories)

- shows the current flow rate and the measuring state
- in intervals of 30 seconds the internal temperature of sensor is displayed



Note: The internal temperature differs from the medium temperature

The displayed information can be customized via software settings. Possible: various units, volume or running time



Error screen:

- shows error codes (see next page)

In case of displayed error codes contact the manufacturer.

Technical data display

Format	128 × 64 Dots
Color	White
Viewing area (W × H)	23.7 × 12.8 mm

Error code	Error	Possible causes and recommended measures
F 0x00	No Measuring error	
F 0x01	Signal value not plausible	Check if:
F 0x10	Signal value not plausible	<ul style="list-style-type: none"> the tubing is firmly secured in the sensor and cannot move? the tubing is filled with a liquid, without large gas bubbles? the lid of the sensor is closed?
F 0x81 or higher	Signal value not plausible, no measurement possible	
G 0x00	No device error	
G 0x01	Checksum error in parameters	Recheck parameters. (software can be used; see opt. accessories).
G 0x02	At least one invalid parameter	
G 0x04	Temperature sensor failed	Power OFF/ power ON the sensor.
G 0x08	DAC failed	If the error persists, return the sensor for repair.
G 0x10	Display failed	

Technical drawings

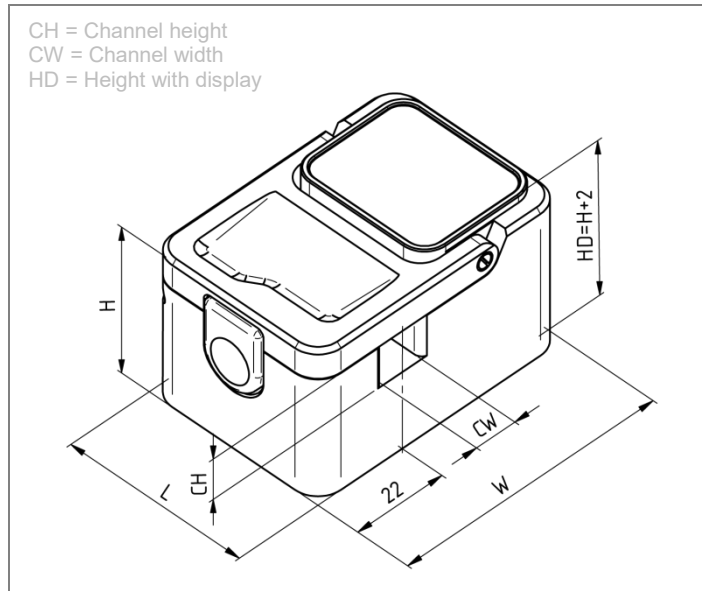

Figure 1: Dimensions SONOFLOW CO.55/xxxSD V2.0

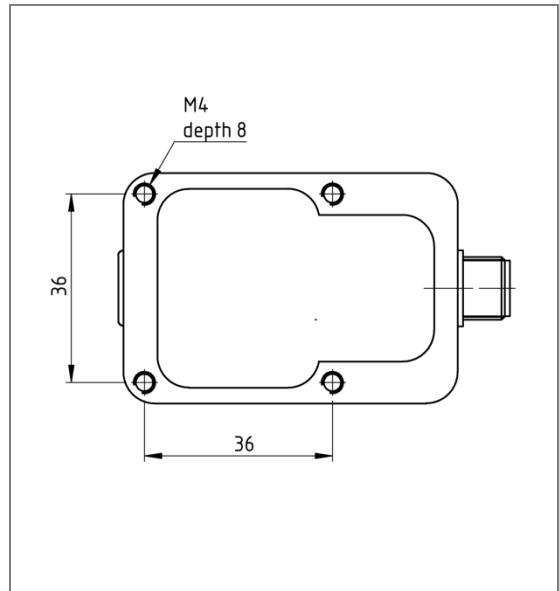

Figure 2: Rear side with drill holes for mounting SONOFLOW CO.55/xxxSD V2.0

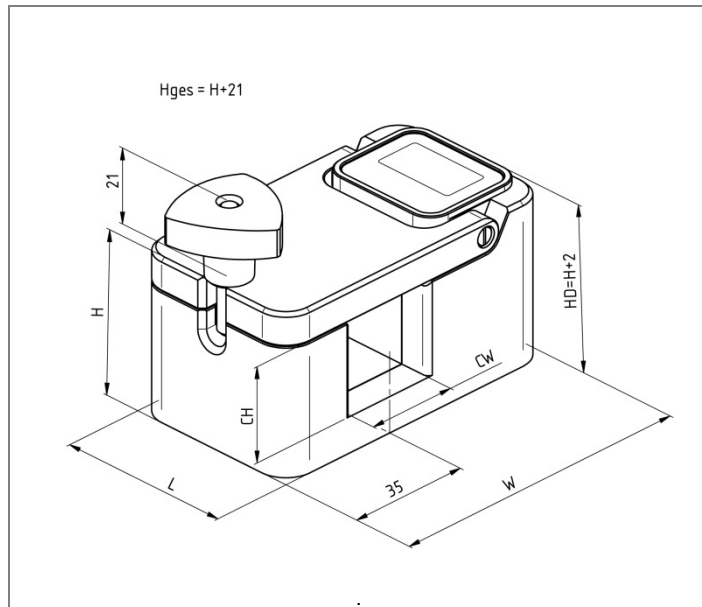

Figure 3: Dimensions SONOFLOW CO.55/xxxSDH V2.0

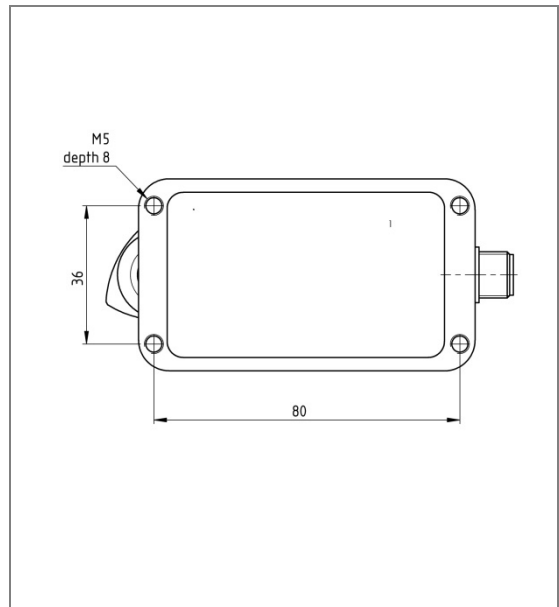

Figure 4: Rear side with drill holes for mounting SONOFLOW CO.55/xxxSDH V2.0

Drawings are not to scale. Dimensions in mm, unless otherwise specified. Information is subject to change without notice! Modbus® is a registered trademark of Schneider Electric and is licensed by the Modbus Organization, Inc.

HEADQUARTERS GERMANY

SONOTEC GmbH
 Nauendorfer Str. 2
 06112 Halle (Saale)
 Germany

Tel.: +49 (0)345 / 133 17- 0
 sales_eu@sonotec.de
 www.sonotec.eu

AMERICAS

SONOTEC US Inc.
 190 Blydenburgh Rd
 Suite 8, 2nd Floor
 Islandia, New York 11749, USA

Phone: +1 631 / 415 4758
 sales@sonotecusa.com
 www.sonotecusa.com